

# OPERATOR'S MANUAL

## RKE 1500W SERIES POWER SUPPLY

SINGLE OUTPUT POWER SUPPLIES  
SINGLE PHASE, POWER FACTOR CORRECTED  
UNIVERSAL AC INPUT

KEPCO INC.  
An ISO 9001 Company.



MODEL  
**RKE 1500W SERIES**  
POWER SUPPLY

RKE 24-50K, RKE 36-42K, RKE 48-32K

#### IMPORTANT NOTES:

- 1) The contents of this manual are protected by copyright. Reproduction of any part can be made only with the specific written permission of Kepco, Inc.
- 2) Data subject to change without notice.

©2017, KEPCO, INC  
P/N 228-1514r6



KEPCO, INC. • 131-38 SANFORD AVENUE • FLUSHING, NY. 11355 U.S.A. • TEL (718) 461-7000 • FAX (718) 767-1102  
email: [hq@kepcopower.com](mailto:hq@kepcopower.com) • World Wide Web: <http://www.kepcopower.com>

# TABLE OF CONTENTS

| SECTION   | PAGE |
|---|------|
| 1. Introduction.....  | 1    |
| 1.1 Scope of Manual.....  | 1    |
| 1.2 Description.....  | 1    |
| 2. Specifications.....  | 1    |
| 3. Installation.....  | 1    |
| 4. Operation.....   | 5    |
| 4.1 Voltage Adjustment.....                                       | 6    |
| 4.2 Remote Voltage Control.....                                   | 6    |
| 4.3 Remote Turn On-Turn Off.....                                  | 7    |
| 5. Alarm Functions.....   | 7    |
| 5.1 POWER FAIL Signal (Optical Coupler Output Alarm Circuit)..... | 7    |
| 5.2 Overvoltage And Overtemperature Protection.....               | 8    |
| 5.3 Overcurrent Protection.....                                   | 8    |
| 5.4 Fan Failure.....  | 9    |
| 5.5 Undervoltage.....   | 9    |
| 6. Load Connection.....   | 9    |
| 6.1 Connecting The Load.....                                      | 9    |
| 6.2 Parallel Connection.....                                      | 9    |
| 6.3 Series Connection.....  | 11   |
| 6.4 Preliminary Electrical Check.....                             | 11   |
| 7. Fan Maintenance.....   | 12   |

## LIST OF FIGURES

| FIGURE | TITLE  | PAGE |
|--------|--|------|
| 1      | Mounting Positions For The RKE 1500W Power Supply.....         | 1    |
| 2      | Mechanical Outline Drawing Of The RKE 1500W Power Supply.....  | 2    |
| 3      | Power Rating Vs. Temperature and Input Voltage.....            | 3    |
| 4      | Locations Of Operating Controls, Indicators and Terminals..... | 6    |
| 5      | Connections For Remote Voltage Control.....                    | 7    |
| 6      | Output Alarm Circuit Optically Isolated.....                   | 8    |
| 7      | RKE 1500W Power Failure Timing Diagram.....                    | 8    |
| 8      | Correct and incorrect Methods of Load Connection.....          | 9    |
| 9      | Parallel Connection with Current Balancing.....                | 10   |
| 10     | Parallel Connection, Master-Slave, Multiple Loads.....         | 10   |
| 11     | Parallel Connection, Master-Slave, Single Load.....            | 11   |
| 12     | Series Connection.....   | 11   |
| 13     | Functional Checkout.....                                       | 12   |

## LIST OF TABLES

| TABLE | TITLE  | PAGE |
|-------|--|------|
| 1     | Output Ratings and Specifications.....       | 3    |
| 2     | Power Supply Ratings and Specifications..... | 4    |
| 3     | Remote Voltage (RV) Adjustment Range.....    | 7    |

## 1. INTRODUCTION

### 1.1 SCOPE OF MANUAL

This Operator's Manual covers the installation and operation of the Kepco RKE 1500W Series of PFC (Power Factor Corrected), RoHS (Reduction of Hazardous Substances) compliant, switching power supplies. For service information, write directly to: Kepco Inc., 131-38 Sanford Avenue, Flushing, New York, 11355, U.S.A. Please state Model Designation and Serial Number of your RKE Power Supply. This information can be found on the nameplate of the unit.

### 1.2 DESCRIPTION

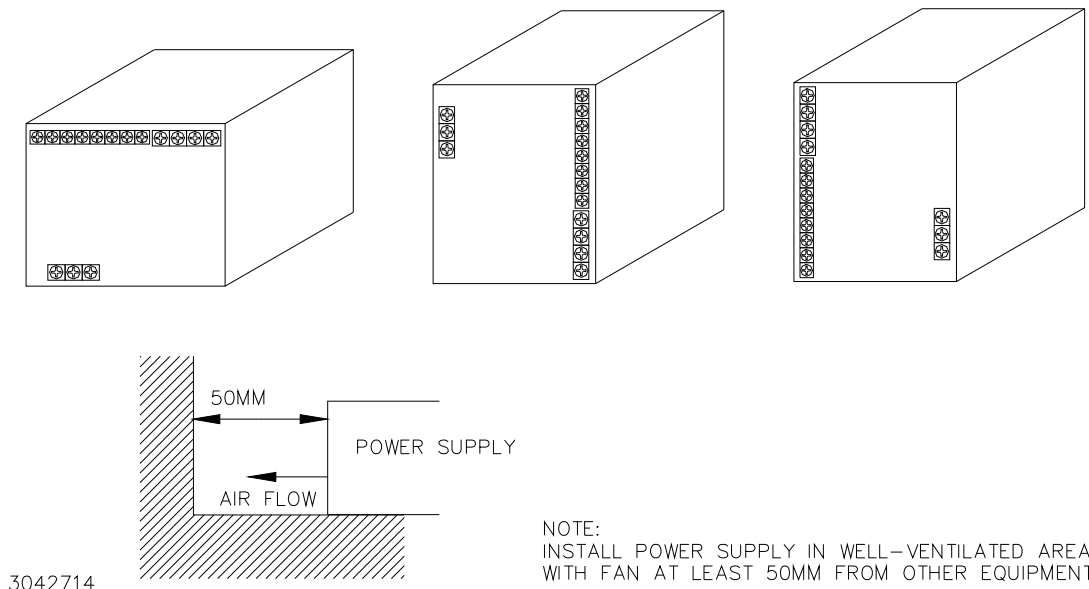
The Kepco RKE 1500W Series consists of three models of switching power supplies, each with a single output as shown in Table 1. Units include PFC (power factor correction) at the input and may be operated with a nominal 100V a-c to 240V a-c (input voltage range 85 to 265 Va-c), 50-60 Hz (input frequency range 47-66Hz). The RKE 1500W Series employs a light weight ferrite core with 135 KHz switching frequency. Regulation is provided by pulse width modulation. A power stage with two MOSFETS on each side of the primary winding, operating in the forward mode, provides a smooth isolated d-c output. A thyristor circuit prevents excessive turn-on current surge. Overvoltage protection and an isolated remote TTL ON-OFF control are provided. An LED "output voltage ON" light and an output voltage adjust trimmer are visible below the control terminals (left side of the case). Units are manufactured on a steel frame with a steel cover.

## 2. SPECIFICATIONS

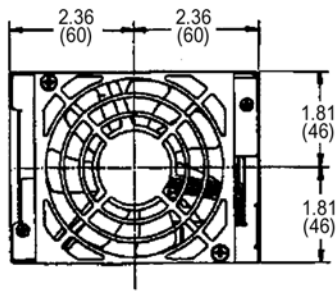
Table 1 contains specifications and operating limits of individual RKE 1500W Series models. Table 2 contains specifications and operating limits common to all RKE 1500W Series Models. These specifications are at nominal input voltages at 25°C unless otherwise specified.

## 3. INSTALLATION

See Figure 1 for allowable mounting positions and orientation. See Figure 2 for mechanical outline dimensions.

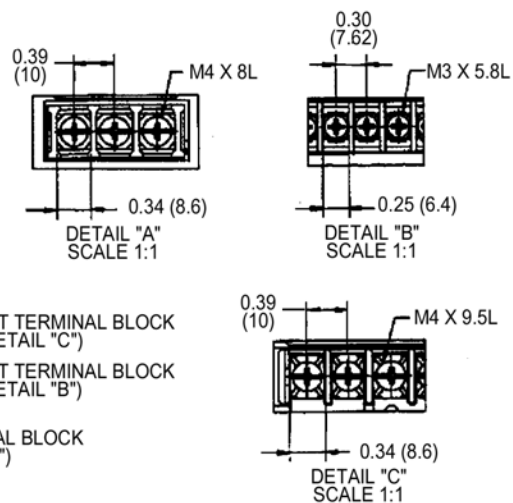
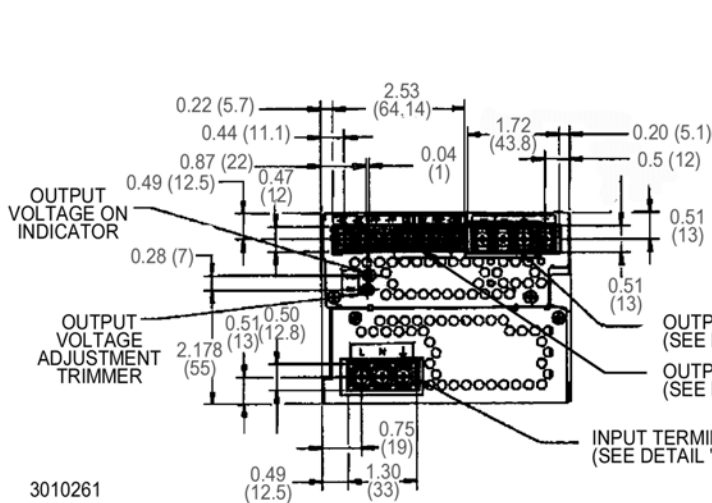
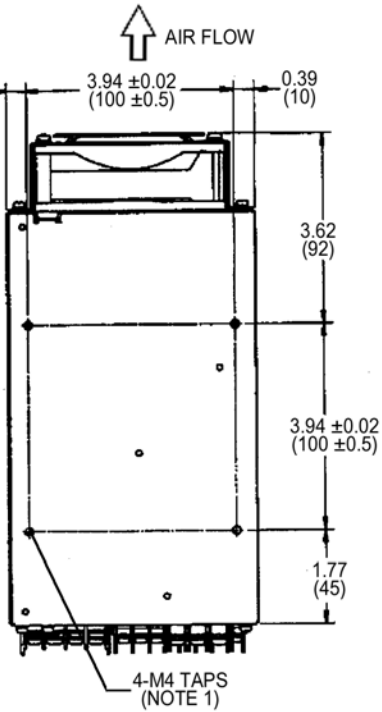
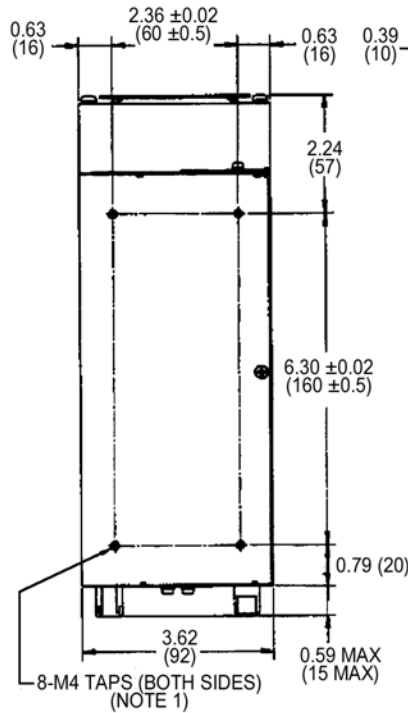
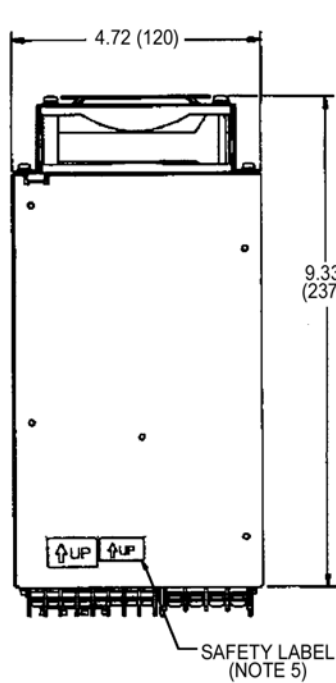


**FIGURE 1. MOUNTING POSITIONS FOR THE RKE 1500W POWER SUPPLY**



**NOTES:**

1. MAX PENETRATION OF M4 MOUNTING SCREWS IS 0.24 (6) FROM CASE SURFACE.
2.  $\pm 0.04$  ( $\pm 1$ ) TOLERANCE UNLESS OTHERWISE SPECIFIED.
3. DIMENSIONS ARE IN INCHES, DIMENSIONS IN BRACKETS ( ) ARE IN MILLIMETERS.
4. REFER TO FIGURE 4 FOR MOUNTING ORIENTATION.
5. IF THE POWER SUPPLY DOES NOT HAVE SAFETY STANDARD OR CE APPROVAL, THERE IS NO LABEL.

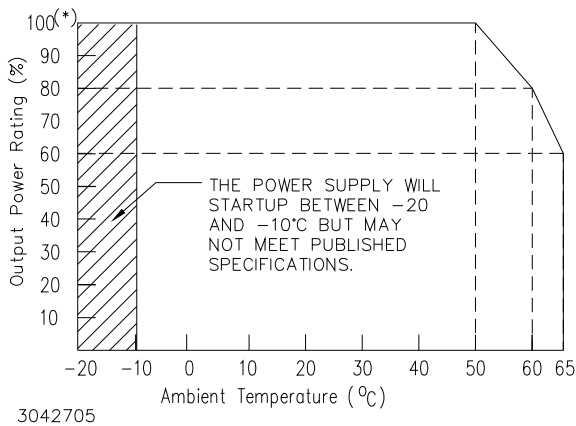


**FIGURE 2. MECHANICAL OUTLINE DRAWING OF THE RKE 1500W POWER SUPPLY**

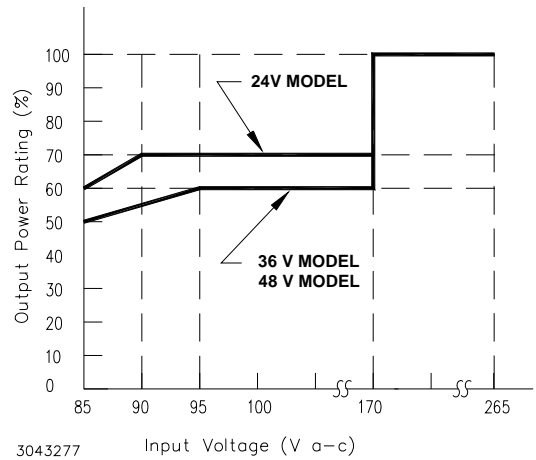
**TABLE 1. OUTPUT RATINGS AND SPECIFICATIONS**

| MODEL RKE 1500W                                |                      | 24-50K                         | 36-42K                   | 48-32K                          |
|--|----------------------|--------------------------------|--------------------------|---------------------------------|
| Output Volts d-c                               |                      | 24V                            | 36V                      | 48V                             |
| Adjustment Range (Volts d-c)                   |                      | 16.8-31.2                      | 25.2-55.0                | 33.6-55.0                       |
| Voltage Setting (Volts d-c)                    |                      | 24 ±0.48                       | 36 ±0.48                 | 48 ±0.48                        |
| Maximum Output Ratings <sup>(1)</sup><br>(A,W) | 85-90V a-c Input:    | 30-35A/720-840W                | N/A                      | 16-19.2A/(768-922W)             |
|  | 85-95V a-c Input:    | N/A                            | 21-25.2A/756-907W        | N/A                             |
|  | 90-170V a-c Input:   | 35A/840W                       | N/A                      | N/A                             |
|  | 95-170V a-c Input:   | N/A                            | 25.2A/907W               | 19.2A/922W                      |
|  | 170-265V a-c Input:  | 50A/1200W                      | 42A/1512A                | 32A/1536W                       |
| Current Limit Setting<br>(Amps) <sup>(2)</sup> | 85 - 90V a-c input   | 31-57.5 <sup>(3)</sup>         | 22.3-48.3 <sup>(3)</sup> | 17-36.8 <sup>(3)</sup>          |
|  | 90 - 170V a-c input  | 36-57.5 <sup>(3)</sup>         | 26-48.3 <sup>(3)</sup>   | 20-36.8 <sup>(3)</sup>          |
|  | 170 - 265V a-c input | 52.5-57.5 <sup>(4)</sup>       | 44.1-48.3 <sup>(4)</sup> | 33.6-36.8 <sup>(4)</sup>        |
| Overcurrent Setting (Amps)                     |                      | 55-65                          | N/A                      | 33.6-36.8                       |
| Current Short Circuit (Amps)                   |                      | 70                             | N/A                      | 45                              |
| OVP Setting (Volts) <sup>(5)</sup>             |                      | 32-35                          | 56-60                    | 56-60                           |
| Low Output Voltage Protection Setting          |                      | 14.4V(≤60% V <sub>Onom</sub> ) | ≤5V                      | 28.8V (≤60% V <sub>Onom</sub> ) |
| Efficiency% typical                            | AC Input 100V        | 83                             | 81                       | 85                              |
|  | AC Input 200V        | 85                             | 86                       | 88                              |
| Ripple & Noise <sup>(6)</sup> (mV, p-p)        | ripple               | 200                            | 300                      | 300                             |
|  | ripple noise         | 300                            | 400                      | 400                             |

- (1) See Figure 3 for power derating vs temperature and input voltage.
- (2) Current limit value determined by the combination of input voltage and output voltage setting. For example, if RKE 48-23K is operated at 120V a-c and output voltage is set at the minimum of output range (33.6V), current limit is closer to the maximum specified value of 36.8A. For the same input voltage (120Vac) if output voltage is set at maximum (55.0V), then the current limit value is closer to 20A (the minimum current limit value specified for input voltage range 90-170V a-c).
- (3) Winker (intermittent) Operation; after cause is removed, output voltage restored automatically, however for some combinations of input voltage and output voltage and current limit characteristics may be square type: see note (4) below.
- (4) Square type. Unit first enters Current Limit; output voltage starts to drop (nearly square curve). If cause is removed while in Current Limit, output voltage restores automatically. If current continues to increase, Overcurrent is triggered. If Overcurrent is combined with an output voltage drop below 60% of rated output voltage (below 5V for 36V model), the unit shuts OFF; recovery is by removing, then reapplying input power after approximately 30 seconds or by opening and (without waiting) reclosing the RC terminals.
- (5) When overvoltage is detected, output is shut OFF. Recovery is by removing, then reapplying input power after approximately 30 seconds or by opening and (without waiting) reclosing the RC terminals.
- (6) Ripple and noise levels above are satisfied when conditions are 0 to 100% load, 0 to 65°C (load is derated from 50 to 65°C, see Figure 3), and bandwidth ≤100MHz.



**POWER RATING VS. TEMPERATURE**



**POWER RATING VS. INPUT VOLTAGE**

**FIGURE 3. POWER RATING VS. TEMPERATURE AND INPUT VOLTAGE**

**TABLE 2. POWER SUPPLY RATINGS AND SPECIFICATIONS**

| CHARACTERISTIC  | SPECIFICATION  | CONDITION/NOTES  |
|---|--|--|
| Input Voltage   | Nominal 100-240V a-c, Range: 85-265V a-c   | (0 to 100% load, -10 to 65°C)  |
|   | Range: 120-370 Vdc   | Polarity insensitive. Safety ratings apply for a-c input operation only. (0 to 100% load, -10 to 65°C)     |
| Input Source Frequency  | Nominal: 50-60 Hz, Range 47-440 Hz.  | At 440 Hz, leakage current exceeds the UL leakage safety specification limit (0 to 100% load, -10 to 65°C) |
| Input Current: (Maximum Load At 25°C with Nominal Output Voltage)   | 12A rms max. (13A rms max. for 48V model)  | 100 - 120V a-c   |
|   | 10A rms max. (8A rms max for 24V model)  | 200 - 240V a-c   |
| Input Protection  | A limiting resistor in series with a resistor fuse (and thyristor circuit) reduces start-up surge. Units are protected against shorts by an input fuse. Fuse value 25.0A At 250 Volts  |  |
| Input Surge cold start, interval > 30 sec ( First surge only, not including current flow into EMI filter) | 15A typ., 20A max. first surge   | 100 - 120V ac  |
|   | 30A typ., 40 max. first surge  | 200- 240 V ac  |
| Leakage Current:  | 0.30mA typ., 0.75mA max.   | 120V a-c, 60Hz per IEC 950 and UL1950  |
|   | 0.60mA typ., 0.75mA max.   | 240V a-c, 60Hz per IEC 950 and UL1950  |
| Power Factor  | 0.99 typical   | 100V a-c, rated output   |
|   | 0.95 typical   | 200V a-c, rated output   |
| Transient Recovery excursion characteristic recovery time   | ±4% maximum  | 50% to 100% load, transient time >50µsec   |
|   | 1 ms maximum   |  |
| Stabilization   | Source Effect (min - max)  | 0.1% Typical, 0.2% Maximum   |
|   | Load Effect  | 1.0% Typical, 2.0% Maximum   |
|   | Temperature Effect   | 0.5% Typical, 1.0% Maximum   |
|   | Combined Effect  | ±1.6% Typical, ±3.2% Maximum   |
|   | Time Effect  | 0.2% Typical, 0.5% Maximum   |
| Start-up Time   | 300 msec Typical, 450 msec Maximum   | 100V a-c   |
|   | 250 msec Typical, 400 msec Maximum   | 200V a-c   |
| Output Hold-up Time   | 10 msec Typical, 7 msec Minimum.   | 100V a-c   |
|   | 10 msec Typical, 7 msec Minimum.   | 200V a-c   |
| Overvoltage Protection  | When the Power Supply goes into an overvoltage condition, the output is cut OFF. To restart (reset) the unit, it is necessary to remove the a-c input power, wait approximately 30 seconds, and then reconnect the a-c input power. An alternative is to open and then reclose the RC terminals (no waiting time required).  |  |
| Low Output Voltage Protection   | If output falls to 60% of rated output (5V for 36V model) for approximately 30 Seconds and overcurrent is triggered, the output is cut OFF. To restart (reset) the unit, it is necessary to remove the a-c input power, wait approximately 30 seconds, and then reconnect the a-c input power. An alternative is to open and then reclose the RC terminals (no waiting time required).                 |  |
| Remote Control ON/OFF:  | "High", 2.4V to 24V (or open), unit OFF- Fan Off ; "Low", 0.0V to 0.4V (or closed), unit ON. Source current is 1.6mA maximum at low level, and sink current is 1.0 mA maximum at high level. The ±RC terminals are isolated from the a-c input terminal and the DC output terminals. When remote ON/OFF is not in use, ±RC terminals must be shorted (use shorting link supplied) for unit to operate. |  |
| Operating Temperature:  | -10 to 65°C  | (see Figure 3.)  |
| Startup Temperature   | -20 to -10°C   | (see Figure 3.)  |
| Storage Temperature:  | -30°C to +75°C   |  |

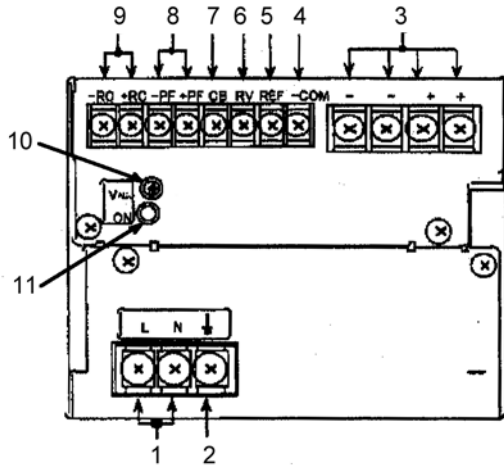
**TABLE 2. POWER SUPPLY RATINGS AND SPECIFICATIONS (CONTINUED)**

| CHARACTERISTIC  | SPECIFICATION   | CONDITION/NOTES  |
|---|---|--|
| Withstanding voltage : (at 15-35°C ambient, 10-85% relative humidity) | 2000Va-c for 1 minute. Cutout current is 20mA   | Between input and ground   |
|   | 500Va-c for 1 minute. Cutout current is 100mA   | Between output and ground  |
|   | 3000Va-c for 1 minute. Cutout current is 20mA   | Between input and output terminal  |
| Insulation Resistance: (at 25°C, 65% relative humidity)               | 100 Megohms minimum (500Vdc)  | Between output and ground, input and ground, and input and output,                                   |
| Humidity:   | 10% to 95% relative humidity, noncondensing, Wet Bulb temperature $\leq$ 35°C   | operating and non-operating  |
| Vibration:  | 5-10 Hz., 10mm amplitude, 10-200 Hz., acceleration 64.3ft./s <sup>2</sup> (19.6M/s <sup>2</sup> ) (2g)  | non-operating 1 hr. on each of 3 axes, sweep time 10 minutes   |
| Shock:  | Acceleration: 964.6ft./s <sup>2</sup> (294M/s <sup>2</sup> ) (30g), Pulse Duration: 11ms $\pm$ 5 msec   | (non-operating, 1/2 sine pulse, three shocks on each axis, Power Supply is fixed on its bottom side) |
| Safety:   | Approved by UL60950-1, CSA 22.2 No. 60950-1 (C-UL), and EN60950-1:2001 +A11 (TÜV), complying with Electrical Appliance and Materials Safety Laws (meeting the regulations of creepage surface and spacial distance in item 8 of the Appendix). RKE 1500W units are CE marked per the Low Voltage Directive (LVD), 73/23/EEC and 93/68/EEC. [The standards do not apply with DC input operation] |  |
| EMC Emission - Conducted:   | Complies with FCC Class B, VCCI-Class B, EN55011-B, EN55022-B   |  |
| EMC Emission - Radiated:  | Complies with FCC Class B, VCCI-Class B, EN55011-B, EN55022-B   |  |
| EMC Emission - Input harmonics current:                               | Complies with EN61000-3-2   |  |
| EMC Immunity  | Complies with EN50082-2   |  |
| EMC Radiated susceptibility:  | Complies with EN61000-4-3 level 3   | normal operation   |
| EMC Conducted susceptibility:   | Complies with EN61000-4-6 level 3   | normal operation   |
| ESD:  | Complies with EN61000-4-2, level 4  | normal operation   |
| Electrical fast transient burst:                                      | Complies with EN61000-4-4 level 3   | normal operation   |
| Surge withstand:  | Complies with EN61000-4-5, level 4  | No damage  |
| Power Frequency Magnetic Field:                                       | Complies with EN61000-4-8, level 4  | normal operation   |
| Voltage dips interruptions and variations                             | Complies with EN61000-4-11  | normal operation   |
| Dimensions:   | 3.62 in. (92 mm) x 4.72 in. (120 mm) x 9.33 in. (237 mm)  |  |
| Mounting:   | Four No. M4 tapped holes on the sides and the bottom  |  |
| Maximum Screw Penetration:  | 0.24 in. (6 mm)   |  |
| Cooling:  | Forced air flow - fan   |  |
| Frame Material/Cover Material:  | Steel   |  |
| Weight  | 6.61 lbs, 3.0Kgs. maximum   |  |

#### 4. OPERATION

Figure 4 shows the location of all operating controls and input/output terminals followed by an explanation of each. The unit is shipped with shorting links installed connecting the following terminals: +RC to -RC and REF to RV

NOTE: If remote ON/OFF is not being used,  $\pm$ RC terminals must be connected (use shorting link supplied) for unit to operate.



NOTE Unit is shipped with shorting links (not shown) connecting +RC to -RC (see PAR. 4.3) and REF to RV (see PAR. 4.2)

LEGEND:

1. **AC input terminals (L, N):** Connect to AC, 100 to 240V, input line.
2. **Frame Ground (earth) terminal:** Connect to earth ground. This terminal is connected to the case.
3. **DC output terminals (+, -):** Connect to load (see Figure 8).
4. **Signal Common (-COM):** Provides return for REF and RV signals
5. **Reference Voltage (REF):** Using the REF terminal (together with the RV terminal), all the output voltages of slave power supplies can be controlled by one voltage adjustment of a master power supply (normally it is shorted with a metal shorting link to the RV terminal).
6. **Output Voltage Adjust (RV):** This terminal (together with the REF terminal) is used for remotely controlling output voltage (see PAR. 4.2).
7. **Current Balance (CB):** This terminal is used when several power supplies are connected in parallel (see PAR. 6.2).
8. **Power failure (+PF, -PF):** These terminals output an open logic signal if output voltage drops to 80% or lower of a set voltage (5V or lower for 36V model), or if output voltage is shut down due to overvoltage or current limit protection, fan speed failure, or overheating. (see Figure 7).
9. **Remote ON-OFF (+RC, -RC):** Output is turned ON-OFF by opening-shorting the RC terminals (output OFF when open). RC terminals are isolated from input and output terminals. Normally,  $\pm$ RC terminals are shorted with a metal shorting link (see PAR. 4.3).
10. **Output voltage adjustment trimmer (V.ADJ):** Adjusts output voltage.
11. **Output ON indicator:** This green LED lights when output voltage is more than 80% of the programmed voltage.

FIGURE 4. LOCATIONS OF OPERATING CONTROLS, INDICATORS AND TERMINALS

4.1 VOLTAGE ADJUSTMENT

Output voltage can be manually adjusted with the voltage adjustment control, Vadj (see Figure 4). To adjust voltage, first place the unit under an operating load, then monitor the (+) and (-) output terminals with a precision voltmeter and turn the voltage control to the desired operating value. Refer to Table 1 for the recommended Adjustment Range of all the RKE 1500W Models

4.2 REMOTE VOLTAGE CONTROL

The unit is shipped with a shorting link in place between RV and REF terminals Removal of this link allows the output voltage to be adjusted by either a trimmer pot (resistance) or by an external variable voltage source across the RV terminal and COM terminal.

NOTE: Specifications are met when voltage is within adjustment range in Table 1. If remote voltage control is not implemented, the shorting link between RV and REF must be in place

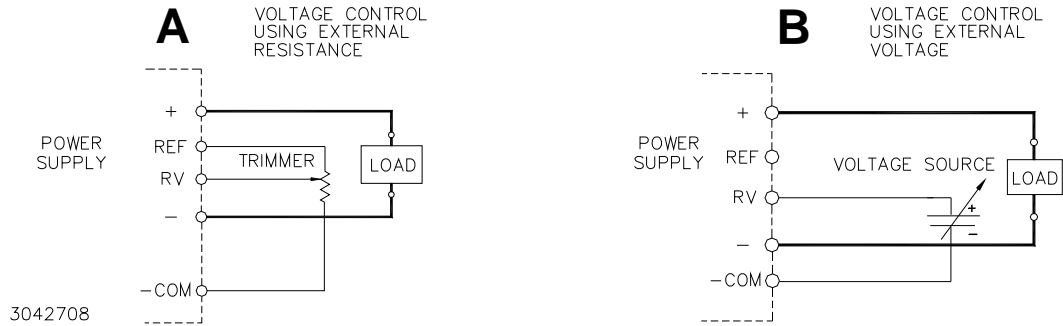
RESISTANCE: Use a shielded wire 6.6 feet (2M) maximum in length, for connection (of REF, RV, and -COM terminals) to the trimmer control. Connect the external trimmer as shown in Figure 5 (A). Suggested value for the trimmer control is 5K ohms. With the external trimmer control at its maximum clockwise position, set the output voltage to the desired maximum value by adjusting Vadj clockwise. The output voltage adjustment range is from 70 to 130% for the 24V model, 17 to 153% for the 36V model, and from 70 to 115% for the 48V model.

VOLTAGE. By adjusting an external 3.5 to 6.5V voltage source the 24V model can be adjusted from 70 to 130% of the nominal output. By adjusting an external 0 to 5.75 voltage source the 36V model can be adjusted from 17% to 153% of the nominal output. By adjusting an external 3.5 to 5.75V voltage source the 48V model can be adjusted from 70 to 115% of the nominal output. Remove the shorting link between the REF and RV terminal. Connect the voltage source across the RV and -COM terminals as shown in Figure 5 (B).



**TABLE 3. REMOTE VOLTAGE (RV) ADJUSTMENT RANGE**

|  | RKE 24-50K | RKE 36-42K | RKE 48-32K |
|--|------------|------------|------------|
| <b>Remote Voltage RV (Volts)</b>         | 3.5 - 6.5  | 0 - 5.75   | 3.5 - 7.5  |
| <b>Output Voltage, % of Vo (nominal)</b> | 70 - 130   | 17 - 153   | 70 - 115   |



**FIGURE 5. CONNECTIONS FOR REMOTE VOLTAGE CONTROL**

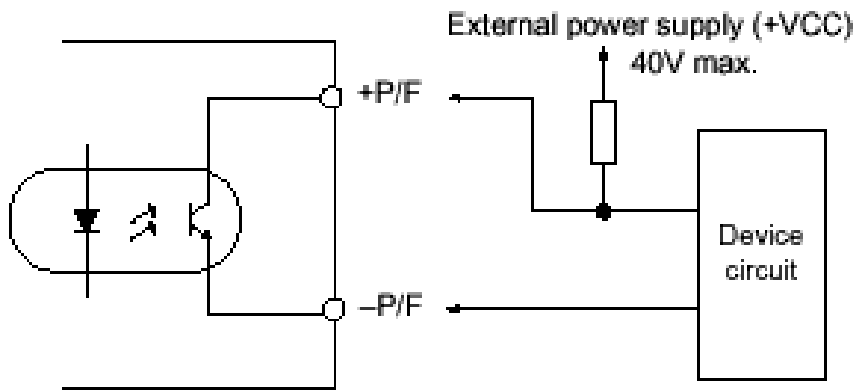
#### 4.3 REMOTE TURN ON-TURN OFF

When power is ON at the source, the output may be turned ON or OFF with the remote control feature using the  $\pm$ RC terminals (see Figure 4). These terminals accept a logic level (2.4V to 24V “high” and 0.0 to 0.4V “low”), or a contact closure. When the  $\pm$ RC terminals are open, using either a mechanical switch or a high level logic signal, the RKE 1500W output is cut OFF. When the RC terminals are shorted, the output returns to within specifications. At low level logic, the maximum source current is 1.6mA and at high level the sink current is 1.0mA. The RC terminals must remain shorted if remote ON-OFF is not used. The RC terminals are isolated from both the AC input and DC output terminals.

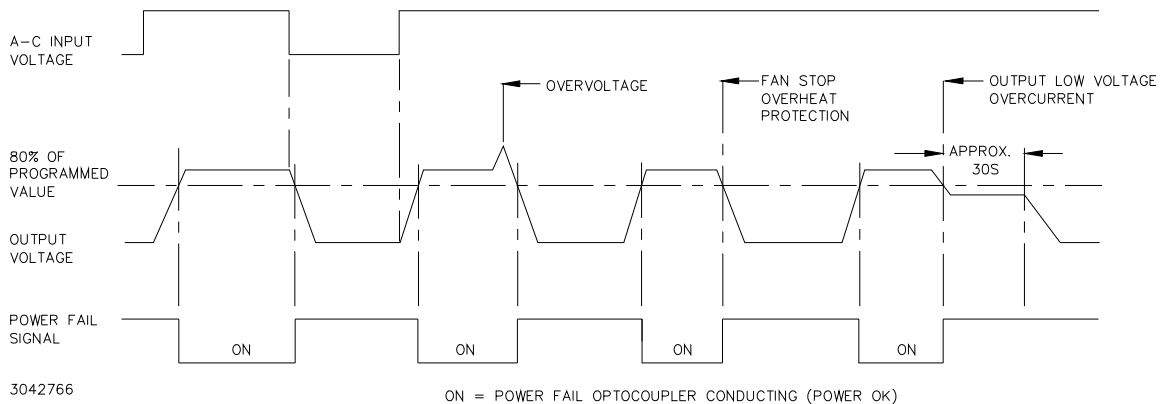
### 5. ALARM FUNCTIONS

#### 5.1 POWER FAIL SIGNAL (OPTICAL COUPLER OUTPUT ALARM CIRCUIT)

The default state of the alarm is logic low: the optocoupler conducts and the green front panel LED is ON (see Figures 6 and 7). The sink current for the optocoupler is 50mA maximum, the maximum collector to emitter saturation voltage is 0.40 Volts, and the collector to emitter voltage is 40 volts maximum. When output voltage drops to less than 80% of programmed voltage (5V or less for 36V model), PF circuit output goes HIGH (optocoupler output transistor in open state), and the front panel LED goes OFF. The PF terminals are isolated from the AC and DC output input terminals. Insulation resistance between the PF terminals and the AC input terminals is the same as the insulation resistance between the input and output. Insulation resistance between the PF terminals and the output terminals is the same as the insulation resistance between the output and ground.



**FIGURE 6. OUTPUT ALARM CIRCUIT OPTICALLY ISOLATED**



**FIGURE 7. RKE 1500W POWER FAILURE TIMING DIAGRAM**

## 5.2 OVERVOLTAGE AND OVERTEMPERATURE PROTECTION

When the output voltage of the RKE 1500W Power Supply increases beyond the specified values (see Table 1), the output is cut OFF and the fan turns OFF. To restart (reset) the unit, remove AC input power, wait approximately 30 seconds, then reconnect AC input power; or open the RC terminals and then reclose the terminals.

When the internal temperature of the RKE 1500W Power Supply increases beyond the specified values (see Table 1), the output is cut OFF and the fans turn OFF. The restart cycle (Power ON) should not begin until the temperature returns to within specifications. To restart (reset) the unit, remove AC input power, wait 40 seconds, then reconnect AC input power. The power supply cannot be reset using the remote ON-OFF feature unless the power supply is first shut down for 30 seconds and then turned on again.

The alarm circuit is a diode transistor optical coupler. The transistor is normally conducting. When the alarm is activated, the transistor cuts off and the collector emitter circuit is open (see Figure 6)

## 5.3 CURRENT LIMIT/OVERCURRENT PROTECTION

From 170 to 265V a-c input, the output characteristic of the power supply is a square type, and the unit is set to shut down if output current exceeds specifications (see Table 1) for more than 30 seconds and undervoltage detection is present (see PAR. 5.5). From 85 to 170V a-c input, operation (including alarm signals) is intermittent when current limit condition occurs. To restart (reset) the unit, remove AC input

power, wait 30 seconds, then reconnect AC input power. or open the RC terminals and then reclose the terminals. (see PAR. 4.3).

## 5.4 FAN FAILURE

A cutoff of the fan supply voltage causes the output to shut down and the fans to turn OFF. Fan failure and all the other protection circuit operations are indicated by an open circuit across the ( $\pm$ ) PF terminals. To restart (reset) the unit remove the AC input power, wait 40 seconds, then reconnect AC input power; or open the  $\pm$ RC terminals and then reclose the terminals. If fan rotation is out of specification the power supply will not recover.

## 5.5 UNDERVOLTAGE

If the output voltage of the power supply falls below 60 percent of the rated voltage for 30 seconds (5V for the 36V model) while overcurrent is detected (see PAR. 5.3), the power supply shuts down and the power failure alarm (see PAR. 5.1) will go to the high logic state. To restart (reset) the unit remove the AC input power, wait 40 seconds, then reconnect AC input power; or open the  $\pm$ RC terminals and then reclose the terminals.

## 6. LOAD CONNECTION

### 6.1 CONNECTING THE LOAD

The load is connected across DC output (+) and (-) terminals (see Figure 8).

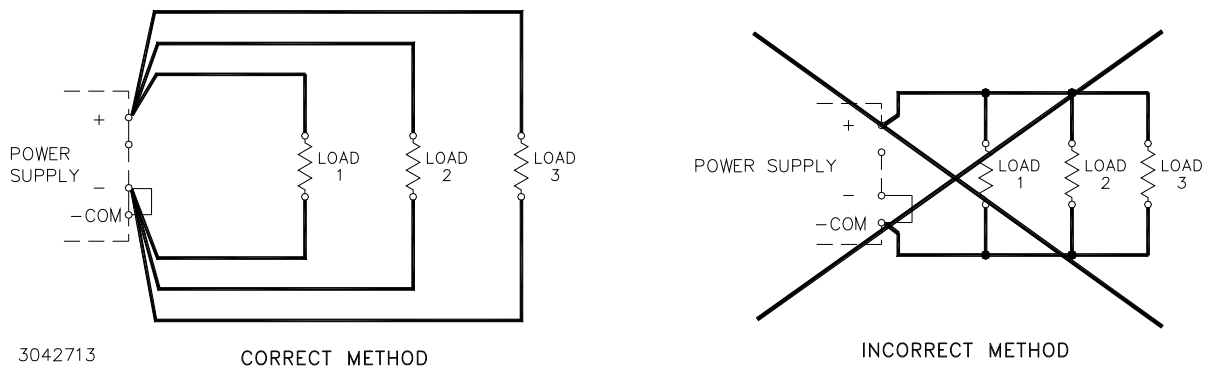


FIGURE 8. CORRECT AND INCORRECT METHODS OF LOAD CONNECTION

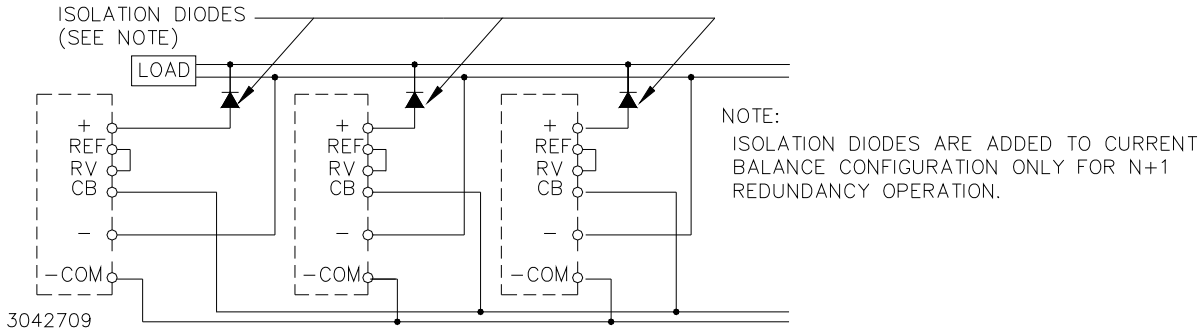
### 6.2 PARALLEL CONNECTION

RKE 1500W Power Supplies can be connected in parallel (with or without N+1 redundancy). The impedance of the load wires between each power supply and load should be the same.

Figure 9 illustrates connection of up to four (maximum) power supplies in parallel. Output current for a parallel connection operating into a single load is equalized by connecting the CB terminals as shown. For a single remote ON-OFF signal to turn off all parallel-connected units, connect together all +RC terminals and connect together all -RC terminals (see PAR. 4.3).

The current equalization with up to four RKE 1500W units in parallel should be within 20 to 90% of the total output current rating. The output voltage of any Power Supply individually must be within 2% maximum of the other power supply output voltage setting. The expected current sharing is such that the output current variation for each power supply is less than or equal to 10% of each power supply rated output current.

**N+1 Redundancy.** An N+1 system requires one additional power supply than necessary to supply the load. If one of the parallel-connected units fail, the others will continue to provide power to the load without down time. For redundancy, add isolation diodes as shown in Figure 9.



**FIGURE 9. PARALLEL CONNECTION WITH CURRENT BALANCING**

**6.2.1 CURRENT BALANCING**

For parallel operation (see Figures 9 or 11) the conditions for current equalization are:

$$\frac{\text{Maximum Voltage} - \text{Minimum Voltage}}{\text{Rated Voltage}} = 2\% \text{ variation of output voltage in each power supply}$$

The maximum output current: Rated output current of each power supply x (number of power supplies) x (20 to 90 percent).

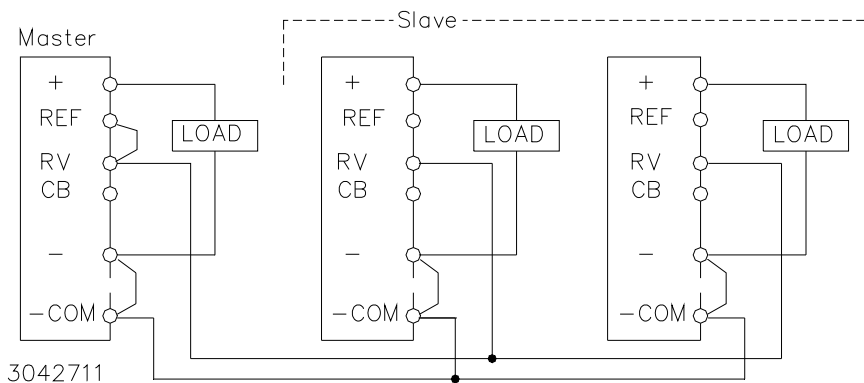
Variation of output current < ±10 % of each rated output current

**6.2.2 MASTER-SLAVE CONFIGURATIONS**

Master-slave operation allows the output voltage of all the power supplies connected in parallel to be adjusted at the same time by using the Vadj control on the designated master power supply.

**6.2.2.1 MASTER-SLAVE, MULTIPLE LOADS**

Figure 10 shows the master-slave connection of three power supplies in parallel, each having an independent load, with output voltage controlled by the Vadj control of the master power supply. Use shielded wire for connections to RV terminals.

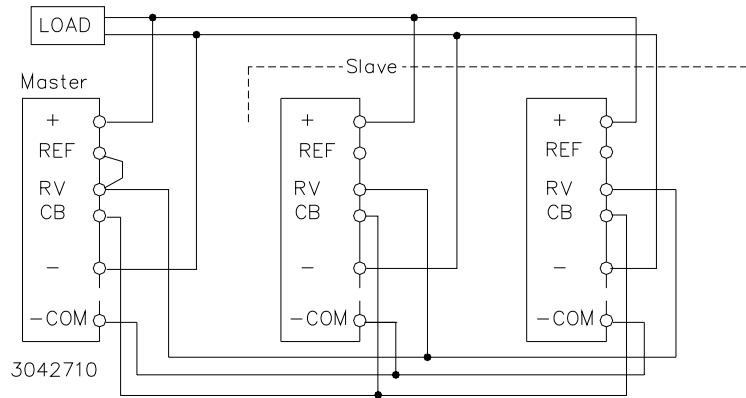


**FIGURE 10. PARALLEL CONNECTION, MASTER-SLAVE, MULTIPLE LOADS**

**6.2.2.2 MASTER-SLAVE, SINGLE LOAD**

Figure 11 shows the connection of three power supplies in parallel to a single load. The output voltage of all power supplies is controlled by Vadj of the master. Current balancing is implemented to equalize

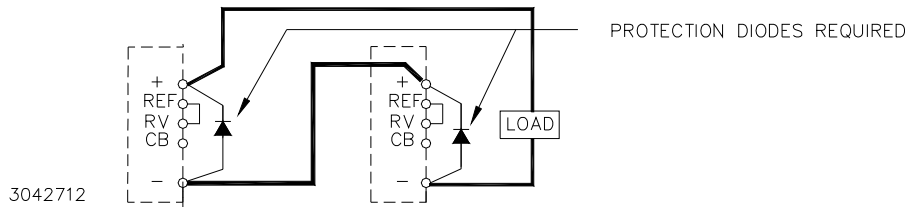
the load current (see PAR. 6.2.1). NOTE: Use shielded wire for connections to RV terminals. Match impedance of load wires between each power supply and load by using the same wire lengths and wire sizes.



**FIGURE 11. PARALLEL CONNECTION, MASTER-SLAVE, SINGLE LOAD**

### 6.3 SERIES CONNECTION

Units may be connected in series to obtain higher voltages. When a number of power supplies are operating in series, the current rating is to be limited to the rating of the power supply with the lowest rating. Each Power Supply in series should be protected by a diode connected in parallel with the output as shown in Figure 12. The diode protects against reverse voltages. It should be rated for typically,  $V_{REVERSE} \geq 2 \times \Sigma V_{OUT}$  of the series connection,  $I_{FORWARD} \geq 2 \times I_{OUT}$  of the series connection).

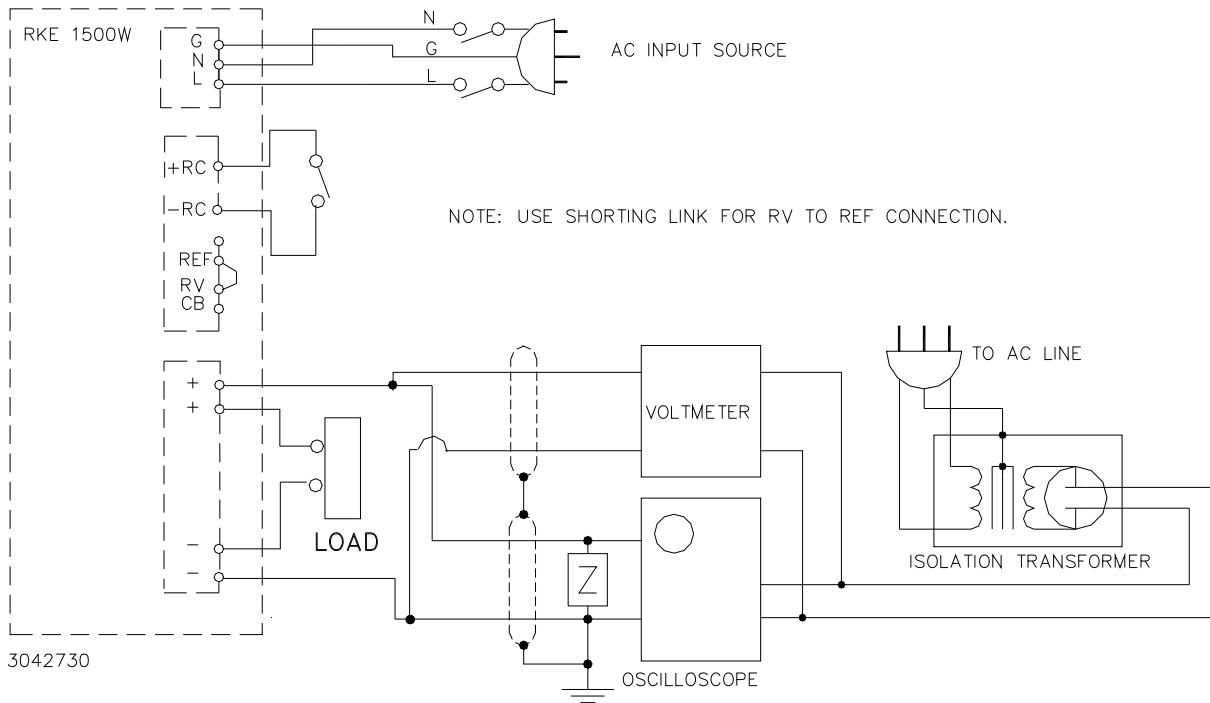


**FIGURE 12. SERIES CONNECTION**

### 6.4 PRELIMINARY ELECTRICAL CHECK

Connect an adjustable load across the power supply DC output terminals, on the right side of the front panel (see Figure 4). The load must have a dissipation rating of at least 3000 Watts. Connect a voltmeter and an oscilloscope across the power supply DC output (+) and (-) terminals. The oscilloscope must be isolated from the source and grounded at the load. Use an isolation transformer between the test equipment and the AC input power (see Figure 13).

Connect the AC input power to the line, neutral and ground terminals (see Figure 4). Turn source power on and check the output voltage both with and without load. The output voltage can be adjusted within the published range by using the front panel voltage control trimmer  $V_{adj}$ .



**FIGURE 13. FUNCTIONAL CHECKOUT**

## 7. FAN MAINTENANCE

Under most conditions the fan requires no maintenance. Do not use the fan in an environment of high temperature and high humidity that exceeds the temperature and humidity limits given in the Power Supply Specifications (see Table 2). Avoid an environment where corrosive gas may be present. If the Power Supply is used in an open or dirty area, a filter should be installed on the air intake side of the fan to prevent the inflow of dust particles. If the Power Supply is used in briny air care should be taken to keep the salt from entering the Power Supply.