

QUICK START GUIDE

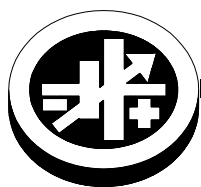

KEPCO An ISO 9001 Company.

RA 19-4C Rack Adapter



RA 19-4C RACK ADAPTER

I — INTRODUCTION

SCOPE OF MANUAL. This Quick Start Guide covers installation and operation of the Kepeco RA 19-4C Rack Adapter for two common configurations. For the full capabilities and specifications of the RA 19-4C and to take advantage of the many choices and features not covered in this Quick Start Guide, the user is urged to download the complete Operator's Manual from the Kepeco web site at www.kepcopower.com/support/opman1s.htm#ra19-4c.

DESCRIPTION. Kepeco RA 19-4C rack adapters are specifically designed for up to four 300W, 600W, 1200W/1500W HSF power supplies, both with -A suffix and older legacy models (non-A suffix).

The rack adapter is user-configurable for parallel, series, or independent power supply operation. Forced current sharing and OR'ing diodes for N+1 redundancy are built into the HSF power supplies. Redundant a-c inputs are provided to deliver independent source power to each power supply in a redundant pair. User-configurable keying can ensure that only the correct power supply can be installed in a keyed slot. Input/output connections between RA 19-4C and HSF power supply are via HSF connectors that plug into corresponding connectors of the RA 19-4C. All connections are made at the rear panel (see Figure 1).

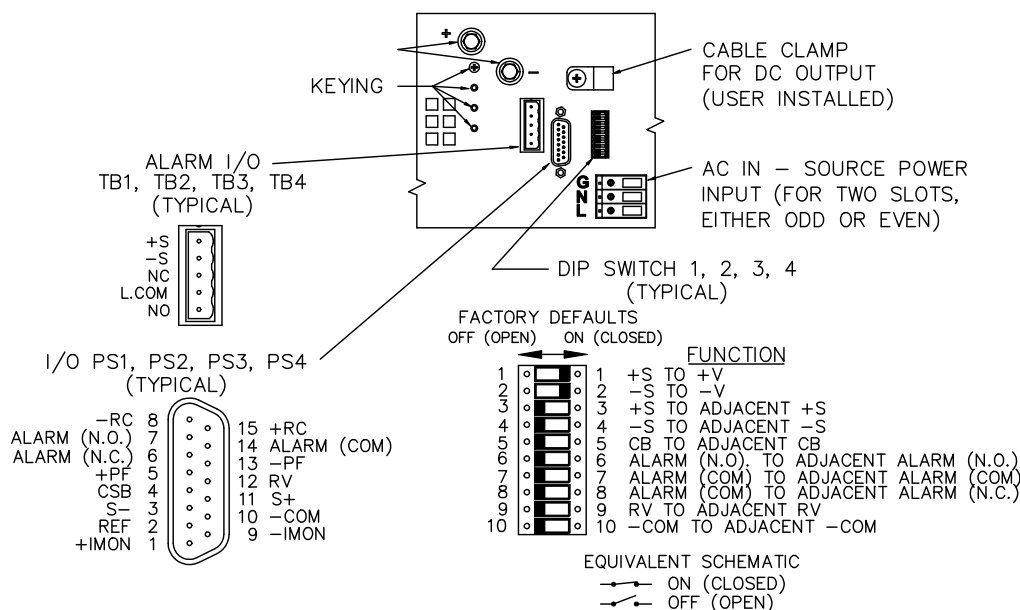

FIGURE 1. REAR PANEL CONNECTIONS, TYPICAL FOR EACH SLOT

II — PRE-INSTALLATION

NOTE: Either local or remote sensing MUST be used except for HSF 1200W/1500W (legacy non -A suffix) models.

DIP SWITCHES. The DIP switches (Figure 1) are arranged as follows: DIP 1 is for PS1 sense lines; DIP 2 is for PS2 sense lines and for paralleling PS1 and PS2. DIP 3 is for PS3 sense lines and for paralleling PS2 and PS3. DIP 4 is for PS4 sense lines and for paralleling PS3 and PS4. Table 1 describes the function of each DIP switch position.

INDEPENDENT OPERATION. The RA 19-4C rack adapter is shipped with the DIP switches of all slots configured for independent operation (see Figure 1) and local sensing.

PARALLEL OPERATION. The most common use for the RA 19-4C rack adapter is with two or more identical HSF modules adjusted to the desired output voltage, connected in parallel to a single load with forced current sharing to increase current output, increase reliability and/or provide redundancy. Only adjacent slots can be connected in parallel using DIP switches.

TABLE 1. REAR PANEL DIP SWITCH FUNCTIONS

DIP SWITCH POSITION	FUNCTION	DIP SWITCH SETTINGS
1, 2	Local / Remote Sensing Selection	Position 1 connects V+ to S+, Position 2 connects V- to S- . Both required ON (factory default) for independent operation with Local Sensing. and for the first slot of a parallel configuration. Both required OFF for: a) Independent configurations using Remote Sensing. b) All series connections. c) All parallel configurations (except for the first slot); use switch positions 3, 4 set to ON to parallel sense connections from the first slot.
3, 4	Connect Sense + and - in parallel	Position 3 connects +S to adjacent slot +S, Position 4 connects -S to adjacent slot -S. Both required OFF (factory default) for all configurations except parallel configurations using DIP switch settings to connect the sense leads in parallel. Both required ON for parallel configurations using DIP switch settings to connect the sense leads in parallel.
5	Current Balance (forced current share)	Required ON for parallel operation with forced current share (connects current share lines in parallel) unless connections are made via external wires Required OFF (factory default) for independent and series configurations.
6, 7	Close on Failure Alarm	When set to OFF (factory default), individual power supplies produce closure between I/O connector N.O. and COM pins upon failure . When set to ON, parallels N.O pins of adjacent slots to allow a single alarm to provide failure indication (contact closure between N.O. pin and COM pin) if any one of many power supplies fails.
8	Open on Failure Alarm	When set to OFF (factory default), individual power supplies produce open between I/O connector N.C. and COM pins upon failure. When set to ON, connects N.C to COM between adjacent slots so that individual alarms are connected in series. This allows a single alarm to provide failure indication (contact open between N.C. pin and COM pin) if any one of many power supplies fails.
9	Remote Voltage	When both set to OFF (factory default), allows independent voltage control of each power supply When both set to ON, enables control of multiple supplies from one power supply designated as the Master. Required OFF (factory default) for independent and series configurations.
10	-Common	

Figure 3 shows HSF's in slots 3 and 4 connected in parallel with forced current sharing and a close-on-fail alarm circuit. Both HSF modules are configured for output voltage to be adjusted from the front panel trimpot (factory default setting). See [Operator Manual](#) for other output voltage adjustment options.

Configure DIP 4:

- Set positions 1 and 2, to OFF to disable local sensing for slot 4.
- Set positions 3 and 4, to ON. This connects sense lines (+S to +S and -S to -S) for slots 4 and 3.
- Set position 5, to ON. This connects the current share bus (CB) for slots 4 and 3.
- Set positions 6 and 7 to ON. Position 6 connects the normally open ALARM (N.O.) lines and position 7 connects the ALARM (COM) (common) for slots 4 and 3, implementing a close-on-fail alarm circuit (see equivalent schematic shown in Figure 3. If either PS3 or PS4 fails, a contact closure provides continuity across pins 7 and 14 of both I/O 4 and I/O 3.
- Set position 8 to OFF. This position is only set to ON for open-on-fail alarm circuits.
- Set position 9 to OFF. Isolates RV (remote voltage) lines between slot 4 and 3, however RV is not used (output voltage is controlled by the front panel trimpot).
- Set position 10 to ON. This connects the common lines (-COM) for slots 4 and 3.

Configure DIP 3:

1. Set positions 1 and 2, to ON. This connects +S to +V and -S to -V for slot 3, establishing local sensing for slot 3.
2. Set positions 3 and 4, to OFF. This isolates sense lines ($\pm S$) between slots 3 and 2.
3. Set position 5 to OFF. This isolates the current share bus (CB) between slots 3 and 2.
4. Set position 6 and 7, to OFF. This isolates the ALARM (N.O.) and ALARM (COM) lines between slots 3 and 2.
5. Set position 8 to OFF. This position is only set to ON for open-on-fail alarm circuits.
6. Set position 9 to OFF. Isolates RV (remote voltage) lines between slot 3 and 2, however RV is not used (output voltage is controlled by the front panel trimpot).
7. Set position 10 to OFF. This isolates common (-COM) lines between slots 3 and 2.

SERIES OPERATION. See [Operator Manual](#) for series operation details.

ALARMS. For independent configurations, Close on Fail contact closure is across I/O connector pins 7 (ALARM N.O.) and 14 (ALARM COM). Open on Fail circuits are across I/O connector pins 6 (ALARM N.C.) and 14 (ALARM COM). Figure 3 shows a parallel close-on-fail circuit for slots 3 and 4 using the DIP switches to make the connections. See [Operator Manual](#) for other options.

III — INSTALLATION

MOUNTING RACK ADAPTER: The rack adapter mounts directly to EIA-RS 310D standard 19" racks via the two mounting ears; two screws are required per mounting ear for proper support. **CAUTION: RACK ADAPTER SHOULD BE MOUNTED BEFORE INSTALLING POWER SUPPLIES.** Install each HSF power supply in desired slot and secure using two retaining latches as described by the applicable HSF Power supply manual. Make sure the two latches are in the open position before installing HSF modules.

The rack adapter is supplied with six cable clamps equipped with release levers that can be snapped into holes provided in the rear panel (see Figure 1) to support the weight of the input, output and signal cables.

OPTIONAL PROTECTIVE COVER: A clear plastic cover (Kepco P/N 137-0145) is available as an accessory to protect the rear terminals against accidental contact. See [Operator Manual](#) for details.

OPTIONAL BUS BAR: Bus bars which connect output terminals for parallel or series operation are available as accessories. See [Operator Manual](#) for details.

OPTIONAL KEYING: HSF power supplies are keyed by voltage at the factory. The keyway is established by installing screws (4-40 x 0.75 in. thread-forming, Kepco P/N 101-0480, provided) into the corresponding holes as indicated in Figure 2 so that the only holes open match the power supply pins. DO NOT OVERTIGHTEN these screws (max torque 5 in.-lbs. (0.6 N x m)). User-modified keying can differentiate between modules with same keyways (e.g., 36V and 48V) or between identical HSF models but with different adjustments; see [Operator Manual](#) for details.

DESIRED VOLTAGE →	5V	12V	15V	24V	28V	36V	48V
⊕ = SCREW TO BE INSTALLED AT REAR PANEL.	⊕	⊕	○	⊕	○	○	○
○ = NO SCREW INSTALLED.	⊕	○	○	○	⊕	⊕	⊕
	○	○	⊕	⊕	○	⊕	⊕
	○	⊕	○	○	⊕	○	○

3042848

FIGURE 2. RACK ADAPTER KEYING

OPTIONAL I/O CONNECTOR: Mating Europlugs (Kepco P/N 142-0544) for the Alarm I/O Euroheaders are available as accessories for the Sense connections ($\pm S$) and independent Alarm connections.

OPTIONAL A-C CONNECTIONS: Two line cords are available as accessories. In North America where 115/230V a-c source power is used, Kepco recommends the use of a Kepco line cord (P/N 118-1145, North American style plug, 30A maximum, 6 ft. long). European applications may require the use of Kepco line cord P/N 118-1146 (250V, 32A maximum).

INSTALLATION/REMOVAL OF HSF POWER SUPPLIES: Use two retaining latches on each HSF power supply to install or remove power supply to/from desired slot in accordance with the applicable HSF Power supply manual. Refer to RA 19-4C [Operator Manual](#) for keeping

the power supplies secure under severe shock or vibration conditions.

NOTES:

1. SLOTS 3 AND 4 CONFIGURED FOR AUTOMATIC MASTER/SLAVE PARALLEL OPERATION, LOCAL SENSING (USING DIP SWITCHES), SENSE CONNECTIONS, CURRENT SHARE AND CLOSE ON FAIL ALARM IMPLEMENTED USING DIP SWITCHES, HSF FRONT PANEL CONTROL OF OUTPUT VOLTAGE.
2. FOR HSF 1200W/1500W, ALWAYS SET POSITIONS 1 THROUGH 4 OF ALL DIP SWITCHES TO OFF.
3. HSF POWER SUPPLIES MUST BE CONFIGURED FOR FRONT PANEL CONTROL OF OUTPUT VOLTAGE.
4. USE I/O MATING CONNECTORS (SUPPLIED) FOR ALARM CONNECTIONS.

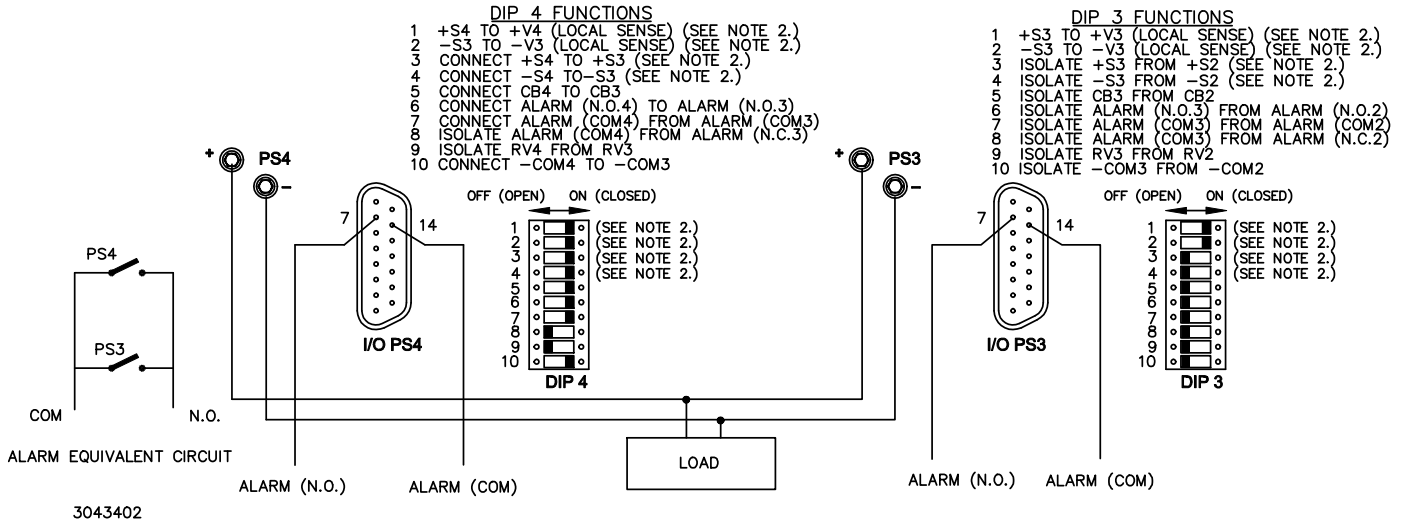

FIGURE 3. SLOTS 3 AND 4 CONFIGURED FOR PARALLEL OPERATION, WITH CLOSE ON FAIL ALARM CIRCUIT

IV — WIRING

A-C WIRING: It is the user’s responsibility to obey all local, national and international safety rules regarding field-wired apparatus and the grounding of the metal cover and case of any instrument connected to the a-c power source. Grounding is an intrinsic part of the safety aspect of the unit.

SOURCE POWER: Source power requirements are determined by the HSF power supply (see HSF power supply Instruction Manual); no adjustment or modification of the rack adapter is required.

Source power can also be custom configured via jumpers on the internal PC board. Contact Kepco Applications Engineering for further details.

Wire size range for each terminal block is AWG 20-10/IEC, rigid: 0.5 - 6mm², or flexible (stranded): 0.5 - 4mm²; torque to 6 lb-in (0.6 N•M) maximum. **CAUTION: DO NOT EXCEED MAXIMUM TERMINAL BLOCK RATING OF 500V AT 36A.** The terminals are labeled L, N, and G. Their functions are:

- Terminal G (Ground) is the safety ground connection for the RA 19-4C.

- Terminals L (Line Phase) and N (Neutral) are connected to the input power entry connectors. Source power is provided to the power supplies indicated by the label on the rear panel.

CONTROL SIGNALS: Access to all the control signals for each HSF power supply is provided via four 15-pin D-subminiature I/O connectors on the rear panel of the rack adapter (see Figure 1). Four mating connectors (Kepco P/N 142-0449) are provided in a plastic bag. Basic functions (Sense and Alarm) are also available via the 5-pin ALARM I/O Euroheader.

OUTPUT LOAD: Load connections to the rack adapters are achieved via four pairs (DC OUTPUT + and -) of output terminals located on the rear panel assembly. Wire gage may be between 22 GA and 6 GA depending on ring lug used; torque to 20 lb-in (2.3 N•M) maximum. As the length of load wires increases, ripple and noise may increase proportionally, therefore length and placement are critical for minimum ripple and noise. A filter consisting of a 50mF electrolytic capacitor in parallel with a 0.01mF capacitor must be used to eliminate unwanted ripple and noise pickup on the load wire during measurements. For noise-sensitive applications the load wires and sense wires must be twisted and/or shielded.