

INSTRUCTION MANUAL



KEPCO An ISO 9001 Company.

**KIT
DIN HWS
-300S**

DIN-RAIL MOUNTING KIT FOR SERIES HWS300

DESCRIPTION. Kepco KITS, Models DIN HWS-300S, contains two preassembled mounting clips and associated hardware used to install HWS300 Series power supplies on a DIN rail. The "S" suffix is for mounting vertically along the short dimension (width) as shown in Figure 1. Outline dimensions are shown in Figure 4.

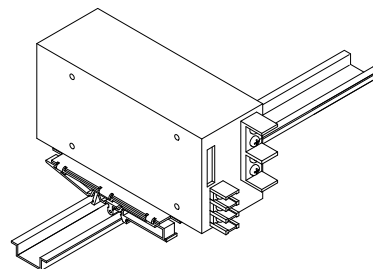

FIGURE 1. S SUFFIX ORIENTATION

TABLE 1. COMPONENTS SUPPLIED

KIT MODEL NO.	MOUNTING PLATE (QTY 2) PART NO.	CLIP (QTY 2) PART NO.	SCREW (QTY 4) PART NO.	SCREW (QTY 4) PART NO.	WASHER, FLAT (QTY 4) PART NO.	WASHER, LOCK (QTY 4) PART NO.	NUT (QTY 4) PART NO.
DIN HWS-300S	128-1984	108-0362	501-0080 (M4 X 6) PHPH)	101-0408 (6-32 X 5/16, FLPO)	103-0028 (NO. 6.)	103-0015 (NO. 6, INT. TOOTH)	102-0004 (6-32 x 1/4, ACF)

INSTALLING KIT. Attach the preassembled mounting clips to the power supply using the hardware supplied (see Figure 3). The clips may be mounted with the release lever on either side to facilitate removal.

INSTALLING POWER SUPPLY ON DIN RAIL. To mount the power supply on the rail insert one end of both clips under one edge of the rail, then snap the other end of the two clips into place (see Figure 2A).

REMOVING POWER SUPPLY FROM DIN RAIL. While grasping the power supply with one hand, use a screwdriver to apply leverage towards the left as shown in Figure 2B to disengage each clip from the rail. Where mounting clips are close together, it may be necessary to apply leverage with two screwdrivers simultaneously.

A — INSTALLATION

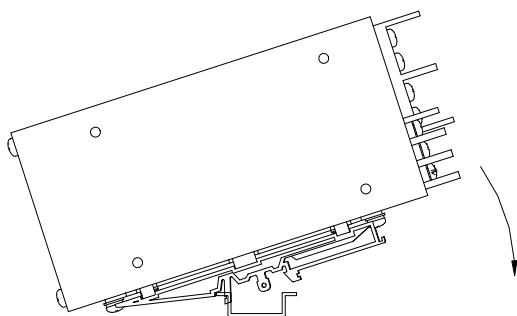

B — REMOVAL

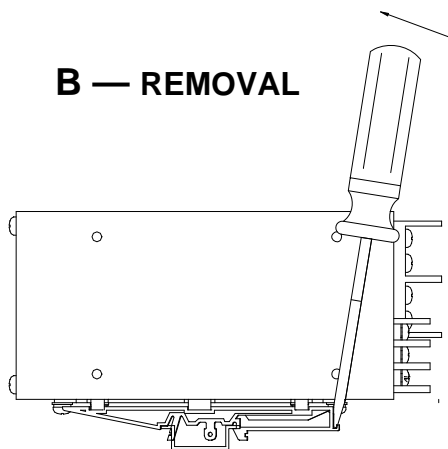
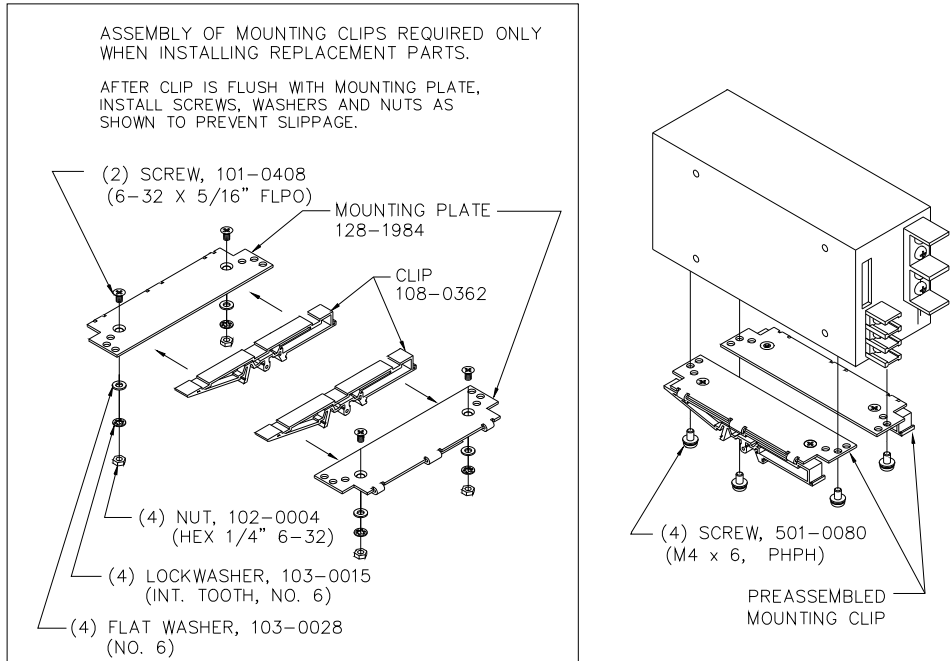

FIGURE 2. INSTALLATION AND REMOVAL OF POWER SUPPLY FROM DIN RAIL

KEPCO, INC. ● 131-38 SANFORD AVENUE ● FLUSHING, NY. 11355 U.S.A. ● TEL (718) 461-7000 ● FAX (718) 767-1102
www.kepcopower.com ● email: hq@kepcopower.com



3043919

FIGURE 3. INSTALLATION OF KIT ON HWS POWER SUPPLY

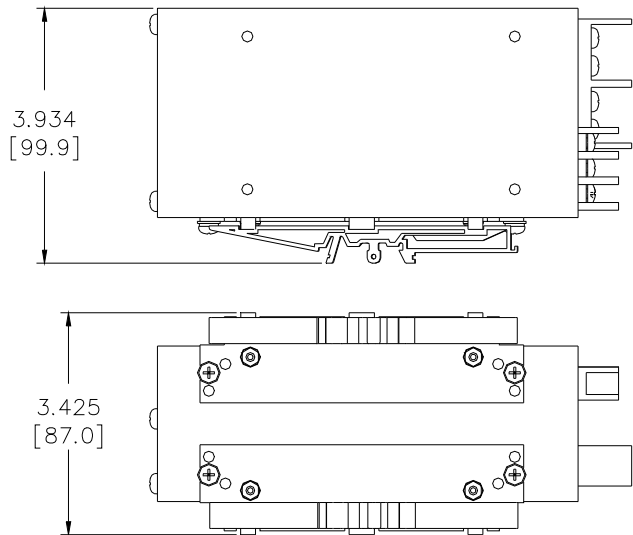

3043921

NOTE: DIMENSIONS IN INCHES. DIMENSIONS IN BRACKETS ARE IN MILLIMETERS.

FIGURE 4. HWS300 POWER SUPPLY WITH KIT INSTALLED, OUTLINE DIMENSIONS