

INSTRUCTION MANUAL



KEPCO An ISO 9001 Company.

**HWS300-
5-27311
12-27312
15-27313
24-27314
48-27315**

HWS300-5-27311, HWS300-12-27312, HWS300-15-27313, HWS300-24-27314, HWS300-48-27315 Zero Up Programmable Power Supply

BEFORE USING THE POWER SUPPLY

Be sure to read the following precautions thoroughly before using this power supply. Pay attention to all warnings and cautions before using the unit. Incorrect usage could lead to an electrical shock, damage or a fire hazard.



WARNING

- Do not make unauthorized changes to the power supply, Electric shock may result and the warranty is void.
- Do not touch the internal components. High voltage or high temperature may be present resulting in electrical shock or burns.
- When the unit is operating, keep your hands and face away from it; an accident may cause injury.
- Do not use unit under unusual conditions (e.g. smoke emission or abnormal smell or sound etc.). Fire and electric shock could result. In such case, please contact the factory; unauthorized repairs are dangerous.
- Do not drop or insert anything into unit. This could cause failure and fire during use.
- Do not operate these units with humidity at condensation. It may cause fire and electric shock.
- The outputs of these products must be earthed in the end use equipment to maintain SELV. If the outputs are not earthed, they must be considered hazardous and must be made not user accessible.



CAUTION

- This power supply is primarily designed and manufactured to be used and enclosed in other equipment.
- This power supply unit has a built-in fan for air-cooling. Blocking the air intake or exhaust could cause fire.
- Input voltage, Output current, Output power, ambient temperature and ambient humidity should be within specifications, otherwise the unit will be damaged.
- The unit might fail by accident or unexpected situation. For applications which require very high reliability (nuclear related equipment, traffic control equipment, medical equipment, etc.), please build redundancy into the equipment for fail safe operation.
- Do not connect wiring improperly to input and output terminals; this may cause damage.
- Do not use in hazardous environments (e.g., strong electromagnetic field, corrosive gas, etc., or any environment where conductive foreign substance may enter).
- Do not operate or store this unit where humidity reaches condensation. In such case, waterproof treatment is necessary.
- Do not operate this unit after it was dropped.
- The output voltage of this power supply is considered to be a hazardous energy level, and must not be accessible to an operator.
- Current share functions when all paralleled units are working properly. However, If one unit faults, the others deliver reduced current. Contact Kepco Applications Engineering if fault tolerant operation is needed.

KEPCO, INC. ● 131-38 SANFORD AVENUE ● FLUSHING, NY. 11355 U.S.A. ● TEL (718) 461-7000 ● FAX (718) 767-1102
<http://www.kepcopower.com> ● email: hq@kepcopower.com

1. Introduction

1-1. Scope.

This manual covers Kepco Model HWS300 power supplies with a 5-digit suffix that have been modified from standard Model HWS300 power supplies.

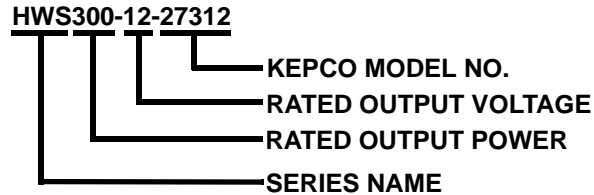

TABLE 1. KEPCO HWS MODELS

KEPCO HWS MODEL	NOMINAL OUTPUT VOLTAGE	RATED OUTPUT VOLTAGE ADJUSTMENT		
		USING EXTERNAL RESISTANCE	USING EXTERNAL VOLTAGE	USING INTERNAL TRIMPOT
HWS300-5-27311	5V d-c	0 to 6V d-c	0 to 6V d-c	4V to 6V d-c
HWS300-12-27312	12V d-c	0 to 14.4V d-c	0 to 14.4V d-c	9.6V - 14.4V d-c
HWS300-15-27313	15V d-c	0 to 18V d-c	0 to 18V d-c	12V to 18V d-c
HWS300-24-27314	24V d-c	0 to 28.8V d-c	0 to 28.8V d-c	19.2V to 28.8V d-c
HWS300-48-27315	48V d-c	0 to 52.8V d-c	0 to 52.8V d-c	38.4V to 52. V d-c

NOTE: For complete specs, except for output voltage adjust, see:
www.kepcopower.com/specs/hws300-1500-series.pdf

1-2. Modifications of Standard

The following modifications have been made to HWS300 models with the 5-digit suffix:

- a) Added a remote programming voltage (/PV) function using either connector CN1 or CN2, pin 7, (PV) input; The voltage programming input presents about 5 Kohm impedance with respect to pin 6 (COM). Pin 6 (COM) is internally connected to pin 4 (-S).
- b) Added a reference voltage source of about 4 to 7V @ 5 mA max, adjustable from the internal potentiometer. It is available at pin 8, connector CN1 or CN2. Pin 8 was originally not connected (NC), now reasigned as (REF).

1-3. Added Capabilities.

The modified units are now capable of output voltage control from 0 to 120% of rated (nominal) voltage.

- a) **Voltage Control using External Resistance.** An external potentiometer (5 to 20 Kohms) can be connected between pin 8 (REF) and pin 6 (COM), with wiper connected to pin 7 (PV) to adjust output voltage from 0% to 120% of nominal when (REF) voltage is adjusted to about 6V using HWS internal potentiometer.
- b) **Voltage Control using External Voltage Source.** An external programming voltage from 0 to 6V applied between pin 7 (PV) and pin 6 (COM) adjusts output voltage from 0% to 120% of nominal. A 5V programming voltage programs the HWS module to nominal output voltage $\pm 2\%$.
- c) **Voltage Control using Local Internal Potentiometer.** If pin 7 (PV) is connected to pin 8 (REF), unit functions as a standard HWS module. The internal potentiometer can adjust HWS output voltage between 80% to 120% of nominal (80% to 110% for HWS300-48-27315).

2. Controls, Indicators and Terminations

CAUTION: Please pay extra attention to the wiring as incorrect connections will damage the power supply.

2-1. Front Panel

1. V.ADJ: Output voltage adjustment trimmer.
(The output voltage rises when the trimmer is turned clockwise.)
2. ON: Output (Power On) indication LED
(The indicator turns on when the power supply output is in normal operating condition.)
3. CN1, CN2: Remote Sensing, ON/OFF control signal, Current balance signal, Power fail signal, Output voltage external control signal. (Refer to PAR. 2-2.)
4. \perp : Protective Earth (Frame ground), M4 screw.
5. AC Input terminal L: Live Line (Fuse in line), M4 screw.
6. AC Input terminal N: Neutral Line, M4 screw.
7. +: + Output terminal: M4 screws (2)
8. -: - Output terminal: M4 screws (2)

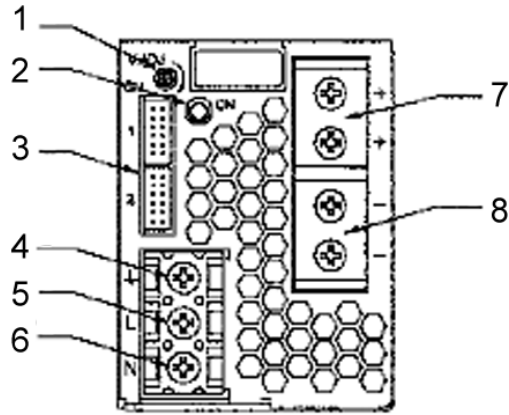

FIGURE 1. HWS300 FRONT PANEL CONTROLS, INDICATORS AND TERMINATIONS

2-2. CN1, CN2 Connector pin Configuration and Function

- CN1 and CN2 have the same pin configuration and function.
- They are connected to each other in parallel inside this power supply.
- When pins of CN1 are shorted, the same pins of CN2 are also shorted.
- Please note that different functions cannot be separately set with CN1 and CN2.
- Mating connectors for CN1 and CN2 are not supplied; see Table 3 for mating connector accessories.

CAUTION: Properly wired connector CN1 or CN2 is required for the unit to function.

TABLE 2. CONNECTOR CN1, CN2 PIN FUNCTIONS

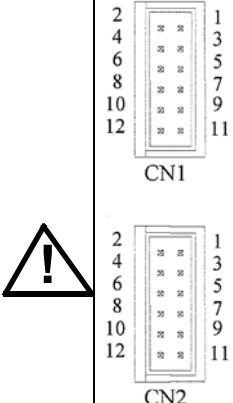
	Pin No.	Designation	Function
	1	+Vm	+Output monitor terminal. Connected to +Output terminal. (+Vm terminal can not supply load current.)
	2	+S	Remote sensing terminal for +output. Remote sensing compensates for line drop between power supply terminals and load terminals. Connect to +Vm terminal when remote sensing function is not used.
	3	-Vm	-Output monitor terminal. Connected to -Output terminal. -Vm terminal can not supply load current.
	4	-S	Remote sensing terminal for -output. Remote sensing compensates for line drop between power supply terminals and load terminals. Connect to -Vm terminal when remote sensing function is not used.
	5	PC	Current balance terminal. For output current balancing in parallel operation. CAUTION: Current balancing functions only when all parallel units are functioning. If one parallel unit faults, the others deliver reduced current. Contact Kepco Applications Engineering if fault tolerant operation is required.
	6	COM	GND for PC, PV, and REF signals.
	7	PV	Remote programming voltage (PV) input; presents about 5 Kohm impedance with respect to pin 6 (COM). Pin 6 (COM) is internally connected to pin 4 (-S). (See NOTES 1,2 and 3.)
	8	REF	Reference voltage source of about 4 to 7V @ 5 mA max, adjustable from the internal potentiometer. (See NOTES 1,2, and 3.)
	9	CNT	Remote ON/OFF control terminal. Power supply ON/OFF control with an external signal.
	10	TOG	GND for CNT and PF signals. (Same as Pin No.12.)
	11	PF	Power fail signal (PF signal) output terminal. If the output voltage drops, or FAN stops and AC input voltage down, Power Fail terminal will output High.
	12	TOG	GND for CNT and PF signals. (Same as Pin No.12.)

NOTES:

1. Voltage Control using Internal Potentiometer Vadj. If pin 7 (PV) is connected to pin 8 (REF), unit functions as a standard HWS module. Vadj can adjust HWS output voltage from 80% to 120% of nominal.
2. Voltage Control using External Resistance. An external potentiometer (5 to 20 Kohms) can be connected between pin 8 (REF) and pin 6 (COM), with wiper connected to pin 7 (PV) to adjust output voltage from 0% to 120% of nominal when (REF) voltage is adjusted to about 6V using HWS internal potentiometer.
3. Voltage Control using External Voltage Source. An external programming voltage from 0 to +6V applied between pin 7 (PV) and pin 6 (COM) adjusts output voltage from 0% to 120% of nominal. A +5V programming voltage programs the HWS module to nominal output voltage $\pm 2\%$.

TABLE 3. MATING CONNECTOR ACCESSORIES FOR CN1, CN2 (NOT SUPPLIED)

ITEM	PART DESCRIPTION	MFR PART NO	KEPCO PART NO.	FUNCTION
1	Socket Housing (1 per connector CN1, CN2)	PHDR-12VS (JST)	142-0575	Mating Connector for CN1, CN2 (see PAR. 6-1 for assembly of mating connector)
2	Terminal Pins (up to 12 per each connector CN1, CN2)	SPHD-002T-P0.5(AWG28-24) (JST)	107-0425	Mating Connector for CN1, CN2 (see PAR. 6-1 for assembly of mating connector)
3	Hand Crimping Tool	YRS-620(SPHD-002T-P0.5) (JST)	N/A	Construct Mating Connector for CN1, CN2 (see PAR. 6-1 for assembly of mating connector)
4	Wiring Kit for HWS Series	KIT 219-0594 (KEPCO)	KIT 219-0594	Includes fully assembled mating connector for CN1, CN2 plus nine 24 AWG wires with pins crimped at one end, other end unterminated.
5	Prewired mating connector for CN1, CN2	518-0123 (KEPCO)	518-0123	Mating connector for CN1, CN2, configured for operation with internal trimpot.

NOTE: A mating connector (either items 1 and 2, item 4 or item 5) is required for unit to operate.

3. Terminal Connections

CAUTION: Pay extra attention to the wiring. Incorrect connection will damage the power supply.

- Input AC-Line should be off when connecting input and output wiring and CN1, CN2.
- Input wiring and output wiring should be separated to improve noise sensitivity.
- The protective earth (PE) must be connected to the \perp terminal or chassis.
- Remote sensing lines shall either be twisted or shielded wires.
- Remote ON/OFF control lines shall either be twisted or shielded wires. Separate from load line.
- Output current of each terminal screw shall be less than 40A for HWS300.

3-1. Local/Remote Sensing (See Figure 2.)

BASIC CONNECTION (LOCAL SENSING)

Connect +S terminal to +Vm terminal and -S terminal to -Vm terminal. Connect CNT terminal to TOG terminal with the attached jumper.

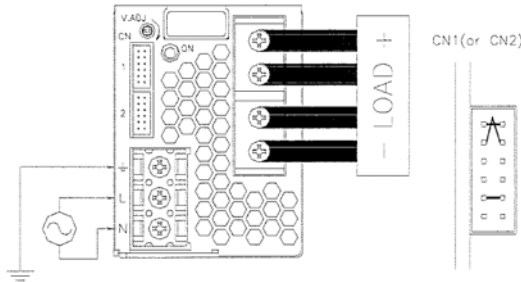

REMOTE SENSING REQUIRED

Connect +S terminal to + terminal of load and -S terminal to - output terminal of load with wires.

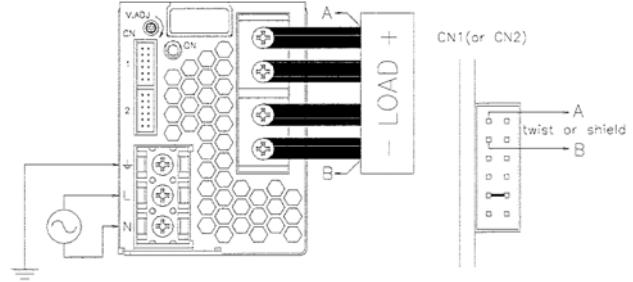

FIGURE 2. LOCAL/REMOTE SENSING CONNECTIONS

3-2. Remote On-Off Control (See Figure 3.)

NOTE:

TOG terminal is ground for CNT terminal.

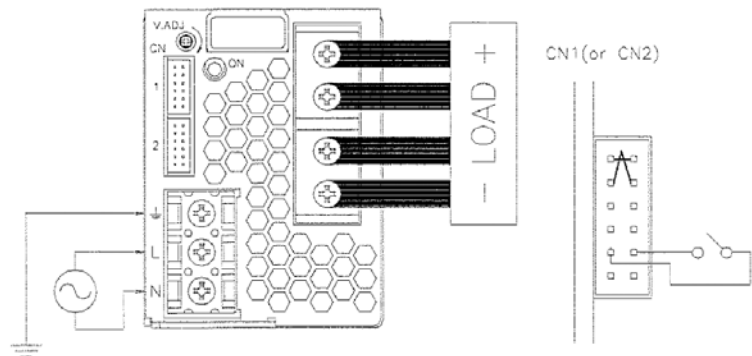

FIGURE 3. REMOTE ON-OFF CONTROL

3-3. Power Fail (PF) Signal (See Figure 4.)

NOTE:

Use open collector method shown. TOG terminal is ground for PF terminal.

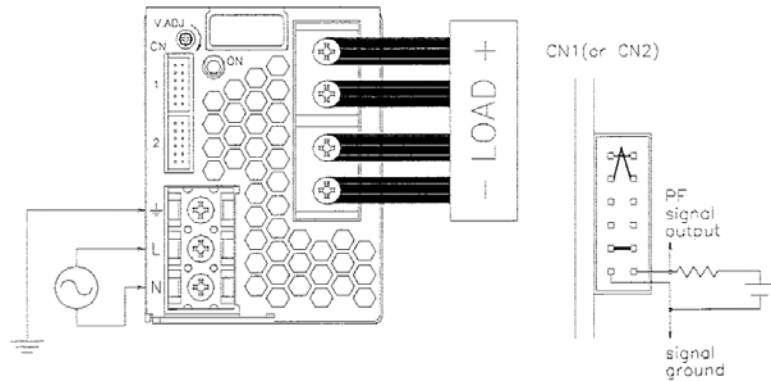

FIGURE 4. REMOTE ON-OFF CONTROL

4. Functions and Precautions

4-1. Input Voltage Range

Input voltage range is single phase 85 ~ 265V AC (47 ~ 63Hz) or 120 ~ 330VDC. Input voltage which is out of specification may cause unit damage. Rated input voltage for safety standard application is 100V-240V AC (50/60Hz).

4-2. Output Voltage Range, External Voltage Control (PV)

Output voltage is set to the rated value at shipment. Turning the trimmer clockwise increases the output voltage.

NOTE: If output voltage is increased excessively, overvoltage protection (OVP) function may trigger and output voltage will be shut down.

- Three methods of output voltage control are available as shown in Figure 5. Refer to Figure 6 for output voltage linearity and derating specifications.

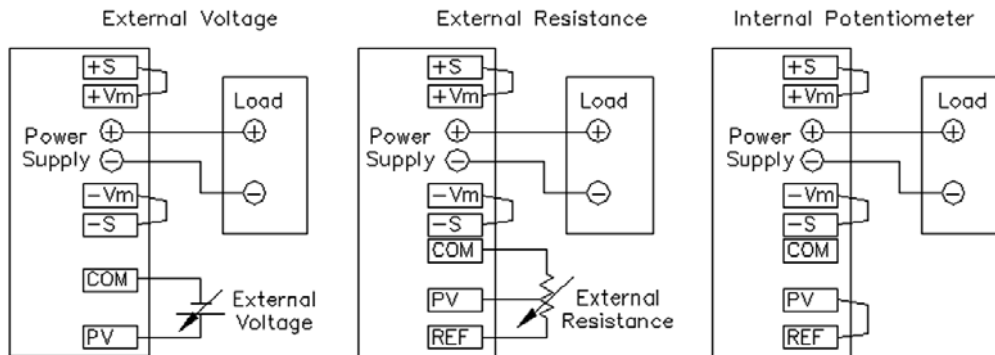
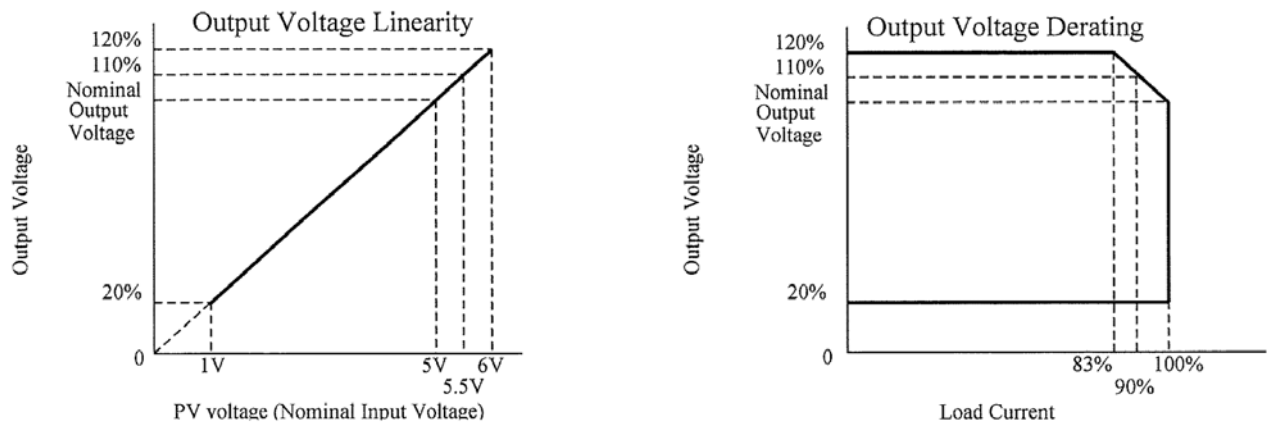

FIGURE 5. OUTPUT VOLTAGE CONTROL, CONNECTION METHODS

- For voltage control using the internal potentiometer (standard HWS module) connect pin 7 (PV) to pin 8 (REF). The internal potentiometer can adjust HWS output voltage from 80% to 120% (80% to 110% for HWS300-48-27315) of nominal. Turning the trimmer clockwise increases the output voltage.
- Voltage can be controlled using an external potentiometer (5 to 20Kohms) connected between pin 8 (REF) and pin 6 (COM). Connect wiper to pin 7 (PV) to adjust output voltage from 0% to 120% of nominal when (REF) voltage is adjusted to about 6V using internal potentiometer.
- Voltage can be controlled using an external programming voltage from 0 to 6V applied between pin 7 (PV) and pin 6 (COM) for output voltage adjustment from 0% to 120% of nominal (5V programs the unit to nominal output voltage $\pm 2\%$)



NOTES:

1. For output voltage adjustment below 20%, please consult Kepco.
2. For HWS300-48-27315 only: Output voltage range limited to 20% to 110% and at PV pin of CN1, CN2, limit voltage range to 1V to 5.5V

FIGURE 6. OUTPUT VOLTAGE LINEARITY AND DERATING

4-3. Over Voltage Protection (OVP)

The OVP function (Inverter shutdown method, manual reset type) is functional. OVP operates within 125% to 145% (115 to 135% for HWS300-48-27315) of the rated output voltage value, and the output will be shut down when OVP function triggers. To reset OVP, remove the power supply input for a few minutes, and then reconnect the input. An alternative is to use CNT (remote ON/OFF) to reset by setting output OFF then ON). The OVP value is fixed and cannot be adjusted. Never apply more than rated output voltage to the output terminal to avoid possible damage to internal leads. For an inductive load, use a decoupling diode at the output line.

4-4. Over Current Protection (OCP)

The OCP function is functional. The OCP characteristic is constant current limiting, automatic recovery. OCP operates when the output current exceeds 105% (119% for HWS300-24-27314) of the maximum DC output current specification. The output is automatically recovered when the overload condition is removed. Never operate the unit under overcurrent or shorted conditions for more than 30 seconds to avoid damage to internal leads. The OCP setting is fixed and can not be adjusted.

4-5. Over Temperature Protection (OTP)

The OTP function (manual reset type) is functional. When ambient or internal temperature rises abnormally, OTP function operates and output will be shut down. After shut down, remove the input AC and cool the unit down to reset OTP. Then reconnect the input.

4-6. Low Output Detection Circuit (PF)

Low output voltage detection is provided. The Power Fail (PF) signal will go to a High level to indicate abnormal status when the output voltage is within 65 ~ 80% of rated value caused by either a drop or brownout of the input voltage or OCP, OVP and OTP function operation. If the built-in FAN motor stops, the PF signal will go High. The PF signal is isolated from input and output by a photo-coupler. It uses the open collector method shown in below.

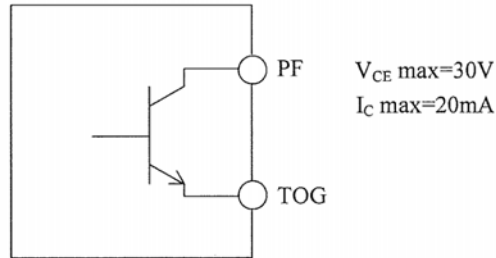

FIGURE 7. LOW OUTPUT DETECTION CIRCUIT

4-7. Remote Sensing (+S, -S terminal)

This function compensates for the voltage drop of wiring from output terminals to load terminals. Connect +S terminal to + terminal of load and -S terminal to - terminal of load with sensing wires (see Figure 8). The sense wires should be twisted. The total line voltage drop (+ side line and - side line) shall be less than 0.3V. If sensing lines are long, it is necessary to put an electrolytic capacitor in the three places noted in Figure 8:

When the remote sensing function is not in use, connect +S terminal to +Vm terminal, and -S terminal to -Vm terminal at connector CN1 or CN2. If remote sensing terminals are opened, the stability and the accuracy of the output deteriorates. Therefore, terminal +S, -S must be connected.

NOTE:

If the sensing wires are too long, it may be necessary to add an electrolytic capacitor in the following locations:

- 1) across the load terminals,
- 2) between +S terminal and + terminal,
- 3) between -S terminal and - terminal.

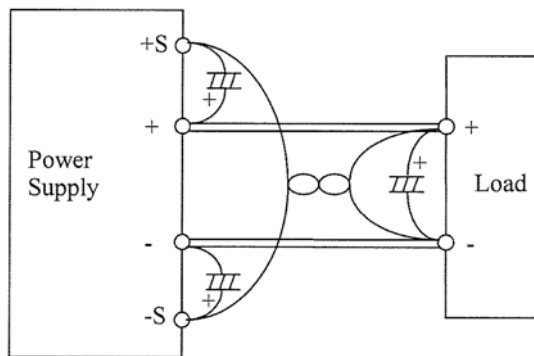

FIGURE 8. REMOTE SENSING CONNECTIONS

4-8. Remote ON/OFF Control

Remote ON/OFF control allows output voltage on/off to be controlled without setting input voltage on/off. The output is turned to ON when TOG and CNT terminals are shorted, and the output is turned to OFF when these terminals are opened. When the function is not used, connect TOG and CNT terminals. The standards for this function are as follows. TOG terminal is return for CNT terminal.

1. TTL compatible. The maximum input voltage to CNT terminal is 12V, and the maximum allowable reverse voltage is -1V. The sink current for CNT terminal is 3.5mA.
2. A switch and relay or a transistor can be used as ON/OFF switch.

3. Remote ON/OFF control circuit (see Figure 9) is isolated from the input and output by a photo-coupler and can be controlled regardless of the output potential (+ or -). Connect TOG terminal to ground of control signal.

TABLE 4. REMOTE ON/OFF CONTROL

CNT Level for TOG Terminal	Output	Built-in Fan
Short or L (0V - 0.8V)	ON	Rotate
Open or H (2.4V - 12V)	OFF	Stop

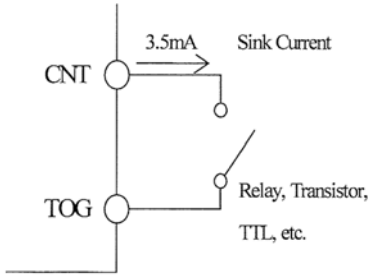

FIGURE 9. REMOTE ON-OFF CONTROL CIRCUIT

4-9. Output Ripple & Noise

The standard specification for maximum ripple value is measured by a specific measurement circuit (JEITA-RC9131A) (see Figure 10). When load lines are longer, ripple becomes larger. In this case, it might be necessary to use an electrolytic capacitor, film capacitor, etc. across the load terminal. The output ripple cannot be measured accurately if the probe ground lead of oscilloscope is too long.

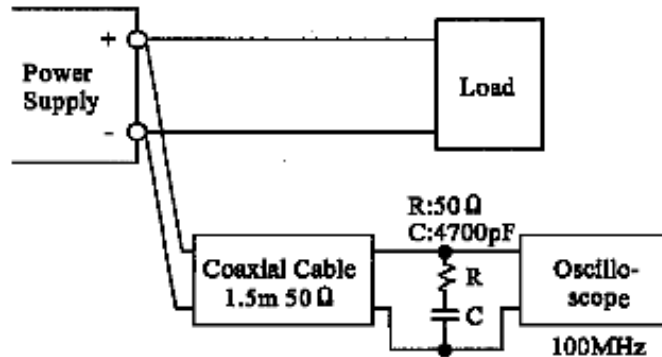

FIGURE 10. RIPPLE/NOISE MEASUREMENT CIRCUIT

4-10. Series Operation

For series operation to increase output voltage, see Figure 11. Both method (A) and (B) are possible. There might be a step in the output rise waveform during series operation.

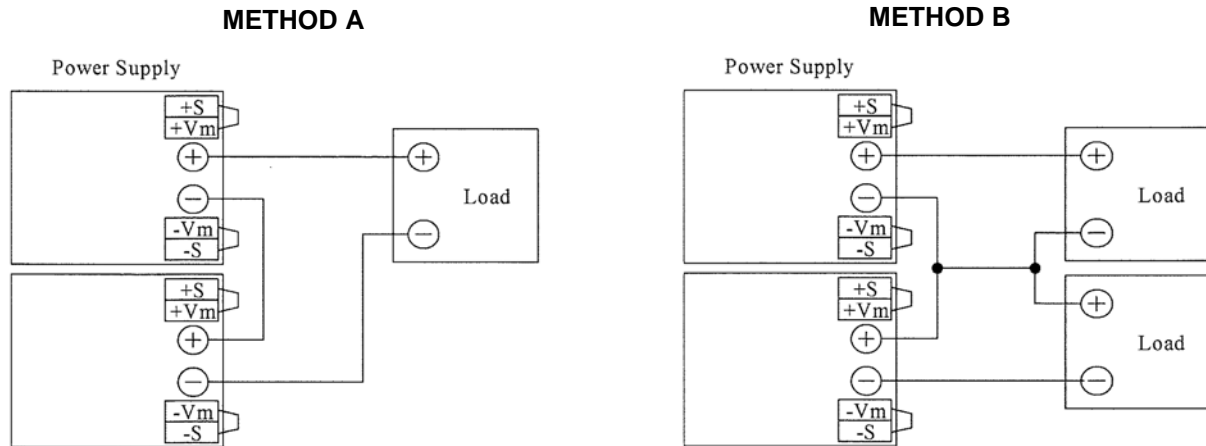

FIGURE 11. SERIES CONFIGURATIONS

4-11. Parallel Operation

Current balancing is functional. Operation modes (Methods A, A-2 and B) shown in Figure 12 are possible.

CAUTION: Current balancing works when all paralleled units are operating properly. If one unit faults, the other units deliver reduced current. Contact Kepco Application Engineering if fault tolerant operation is needed.

(A) To Increase the Output Current

Connecting PC to PC terminal and COM to COM terminal, the current balancing function activates and output current of each power supply is equivalently supplied to load. Wires to PC terminals and COM terminals shall be as short as possible, the same length and twisted.

There is a possibility that the output could be unstable due to external noise. For this case, disconnect the COM terminal and connect -S terminal from parallel power supply to a single point on the load. Please refer connection Method (A)-2 shown in Figure 12.

1. Adjust the output voltage of each power supply to be same value within 1% or 100mV, whichever is smaller.
2. Use same length and type of wires for all load lines.
3. Each power supply must be within the rated output current for all paralleled models.
4. Parallel operation is possible for up to 5 units. '

(B) To Use as a Backup Power Supply (see Figure 12, Method B)

1. Adjust the output voltage of each power supply to be same value.
2. Set power supply output voltage higher by the forward voltage drop of a diode.
3. Each power supply must be within specifications for output voltage and output current.

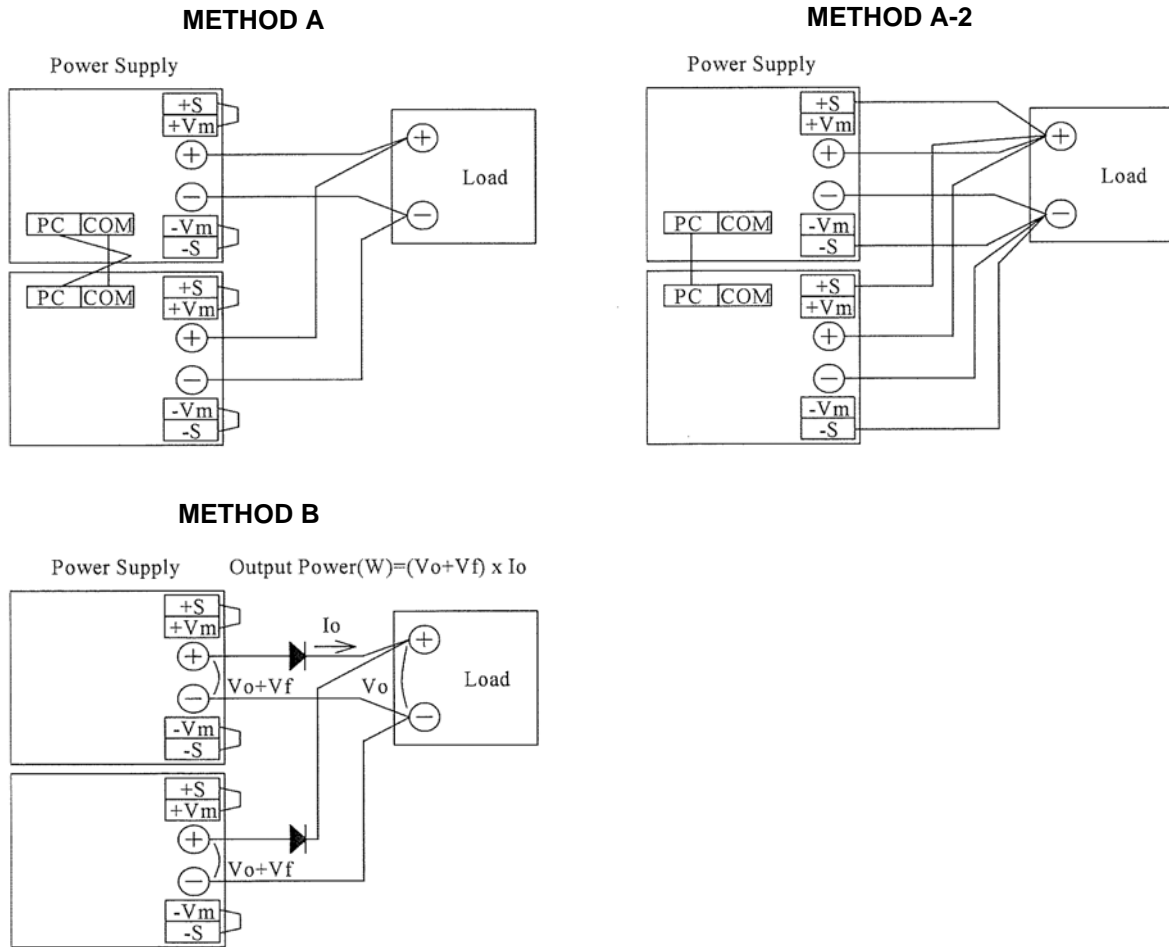

FIGURE 12. PARALLEL CONFIGURATIONS

4-12. Isolation Test

Isolation resistance between output and \perp (chassis) shall be more than 100M Ω at 500VDC and between output and CNT - PF shall be more than 10M Ω at 100VDC. For safe operation, voltage setting of DC isolation tester must be done before the test. Ensure that it is fully discharged after the test.

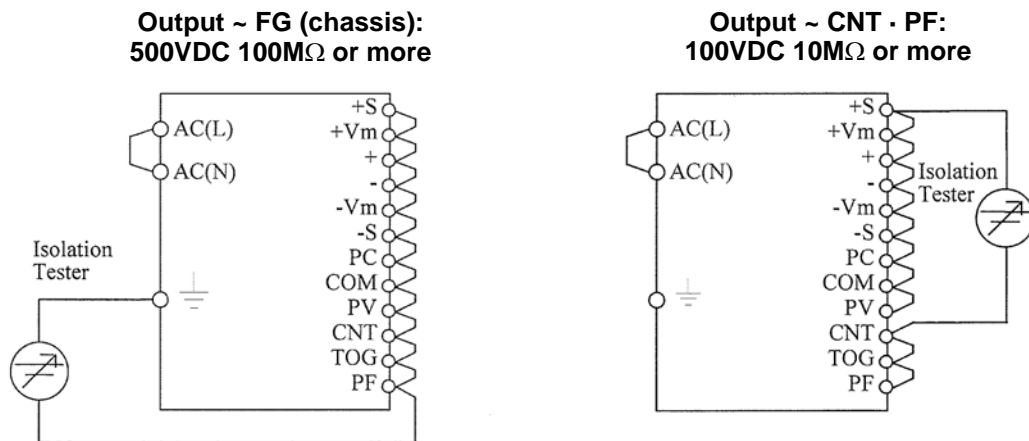

FIGURE 13. ISOLATION TEST CIRCUIT

4-13. Withstand Voltage

This series is designed to withstand 3.0 KVAC between input and output, 2.5 KVAC between input and \perp (chassis), 500VAC between output and \perp (chassis), and 100VAC between output and CNT · PF terminal each for 1 minute. When testing withstand voltage, set current limit of withstand voltage test equipment at 20mA.

(Output ~ \perp (chassis) and Output ~ Control: 100mA).

The applied voltage must be gradually increased from zero to testing value and then gradually decreased for shut down. When timer is used, the power supply may be damaged by high impulse voltage at timer switch on and off. Connect input and output as shown in Figure 14.

HWS Series power supplies have a monolithic ceramic capacitor in the secondary circuit to frame ground. Some withstand voltage testers may generate high voltage and cause damage to the monolithic ceramic capacitor. Therefore it is necessary to check the test voltage waveform.

Input ~ Output: 3.0KVAC 1 min. (20mA)
Input ~ \perp (chassis): 2.5KVAC 1min. (20mA) **Output ~ \perp (chassis): 500VAC 1min. (100mA)** **Output ~ CNT · PF: 100VAC 1min. (100mA)**

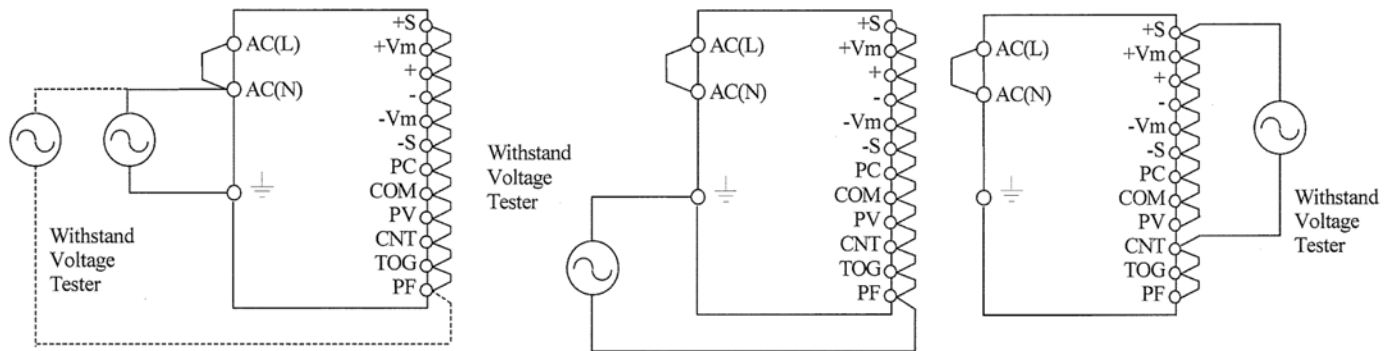

FIGURE 14. WITHSTAND VOLTAGE TEST CIRCUIT

4-14. Output Peak Current (Model HWS300-24-27314 only)

The required conditions for Peak Output Current are shown in Figure 15. Reduce peak current value per derating specified in PAR. 5-2

Input Voltage range : AC180V~265V
 Continuous Peak output time (τ) : Within 10 seconds
 Peak output current (I_p) : Within the rated peak output current
 Average DC output current (I_m) : Within the rated output current

$$I_m = \frac{(I_p - a) \times \tau}{T} + a \leq I_{av}$$

Duty : up to 35(%)

$$\text{Duty} = \frac{\tau}{T} \times 100 (\%)$$

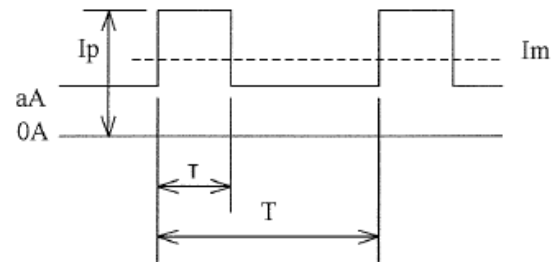

I_p : Peak output current (A)
 I_{av} : Rated output current (A)
 I_m : Average output current (A)
 τ : Peak current pulse width (sec)
 T : Period (sec)

FIGURE 15. OUTPUT PEAK CURRENT REQUIREMENTS

5. Mounting Directions

5-1. Output Derating According to Mounting Direction.

The recommended standard mounting method is (A). Method (B) is also possible. Refer to Figure 16.

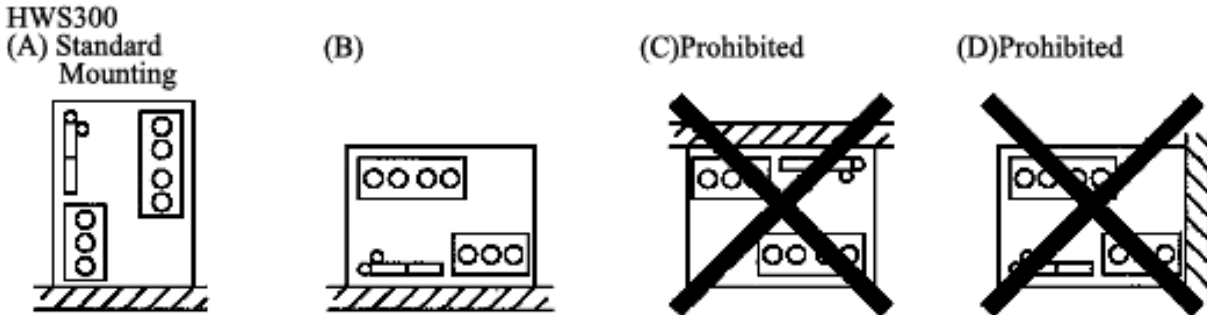
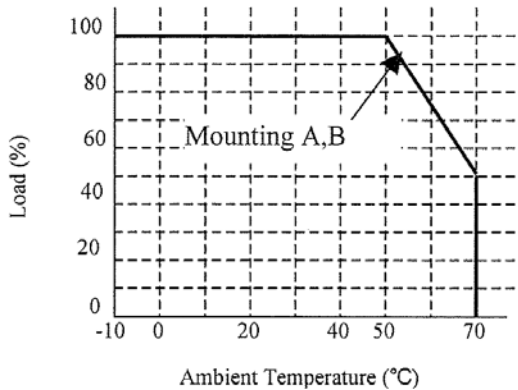

FIGURE 16. PERMITTED MOUNTING ORIENTATION

5-2. Output Derating for Temperature

Refer to Figure 17 for temperature derating.



Ta(°C)	Load (%)	
	Mounting(A)	Mounting(B)
-10 ~ +50	100	
+70	50	

FIGURE 17. TEMPERATURE DERATING

5-3. Mounting Method

1. HWS300 is a forced air cooling type power supply. This power supply has ventilating holes on the front and back side panels. Keep these two areas free of blockage as much as possible (see Figure
2. The maximum allowable penetration is 6mm. Incomplete thread of mounting screw should not be allowed to penetrate.
3. Recommended torque for mounting screw: M4 screw: 1.27 N · m (13.0Kgf · cm)

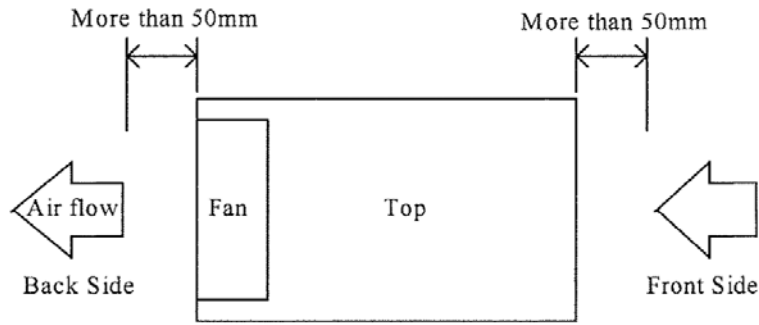

FIGURE 18. FORCED AIR COOLING REQUIREMENTS

6. Wiring Method

1. The output load line and input line shall be separated to improve noise sensitivity.
2. The sensing lines shall be twisted and separated from the output lines for remote sensing.
3. Make all lines as thick and short as possible to lower impedance.
4. Attaching a capacitor to the load terminals can eliminate noise.
5. For safety and EMI considerations, connect \perp terminal to the mounting set ground terminal.
6. Recommended torque for the HWS300 Input, Output terminal (M4 screw): 1.27 N · m (13.0Kgf · cm).

6-1. Assembly of Mating Connector for CN1, CN2

HWS300 Series uses SPHD-001T-P0.5 or SPHD-002T-0.5 connectors made from JAPAN SOLDERLESS TERMINAL MFG CO. LTD. Assembly of the connector is as follows:

a. Applicable Wire and Crimping tool

- Wire size is AWG#26 ~ AWG#22 and insulation outer dia. is $\varnothing 1.0 \sim \varnothing 1.5$ mm.
- Appropriate wire per barrel size is UL1007 (standard wire) and its equivalent standard wire can be used.
- For AWG#22, use UL1061 or equivalent, because wire insulation outer diameter of UL 1061 is small.

TABLE 5. CRIMPING TOOL

Crimping Tool	Crimping Applicator	Dies
AP-K2 or AP-KS	MKS-LS-10 or MKS-L-10	SPHD-001-05/SPHD-002-05

b. Crimping Operation

The reference value for wire stripping is 2.3mm. As wire strip length differs, depending on type of wire and crimping method, decide on the best wire strip length considering processing condition. When stripping wire, do not damage or cut off wire conductors.

TABLE 6. CRIMP HEIGHT

Wire Insulation		Insulation O.D (mm)	Crimp height (mm)	
Type	Size		Conductor part	Insulation part
SPHD-001T-P0.5				
UL1007	AWG #26	1.3	0.60 ~ 0.70	1.7
UL1007	AWG #24	1.5	0.65 ~ 0.75	1.8
UL1061	AWG #22	1.4	0.70 ~ 0.80	1.8
SPHD-002T-P0.5				
UL1007	AWG #28	1.2	0.55 ~ 0.60	1.6
UL1007	AWG #26	1.3	0.60 ~ 0.65	1.7
UL1007	AWG #24	1.5	0.62 ~ 0.67	1.8
NOTES: 1. Crimp height at wire barrel should be set to pre-determined dimensions. 2. Adjust crimp height at wire insulation barrel to the extent that wire insulation is slightly pressed, and set so that crimping is not excessive. 3. Crimping condition at wire insulation barrel shown below in Fig.19, A. 4. For AWG #28, #26 and #24, use UL1007 type. For AWG #22, use UL1061 type.				

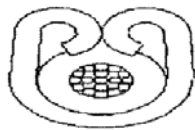

Good

A. Good Crimping

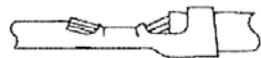

Wire conductor protruding length is long.



Wire conductor protruding length is short.



Wire conductor comes off.

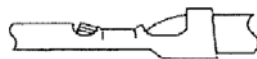

Wire barrel bites wire insulation.

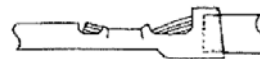

Wire insulation is not crimped sufficiently.

B. Example of Defective Crimping

FIGURE 19. CRIMPING REQUIREMENTS

Check crimping appearance visually for correct crimping by referring to Figure 19.

Check the tensile strength at crimped part when operation is finished

TABLE 7. TENSILE STRENGTH OF CRIMPED PART

Wire Size	Requirement (N min.)	Actual Value (N)
SPHD-001T-P0.5		
UL1007 AWG #26	20	39.2 ~ 45.1
UL1007 AWG #24	30	68.6 ~ 74.5
UL1007 AWG #22	40	92.1 ~ 96.0
SPHD-002T-P0.5		
UL1007 AWG #28	15	27.0 ~ 34.3
UL1007 AWG #26	20	44.1 ~ 48.0
UL1007 AWG #24	30	66.6 ~ 71.5

c. Inserting Contact into Housing

1. Do not apply any pulling force to crimped part, and insert contact parallel to housing
2. Insert contact into housing without stopping to innermost
3. Check secure locking per each insertion by pulling wire softly in order to check that contact does not come off housing. Also, check whether there is backlash in the direction of insertion axis.

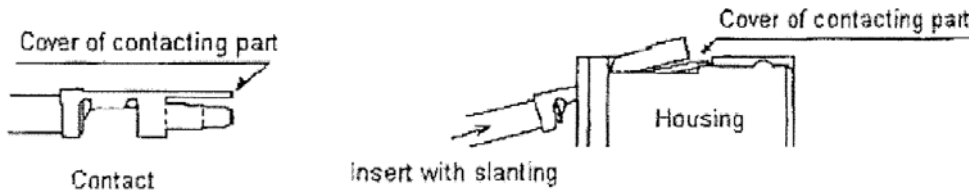

FIGURE 20. INSERTING CONTACT INTO HOUSING

d. Mating and Unmating Connector

1. **Inserting Connector.** Hold receptacle housing securely and insert straight into header against header post until click sounds.
2. **Unmating Connector.** Hold all wires securely and press receptacle housing using fingers so as to pry connector loose, then withdraw it on the mating axis.

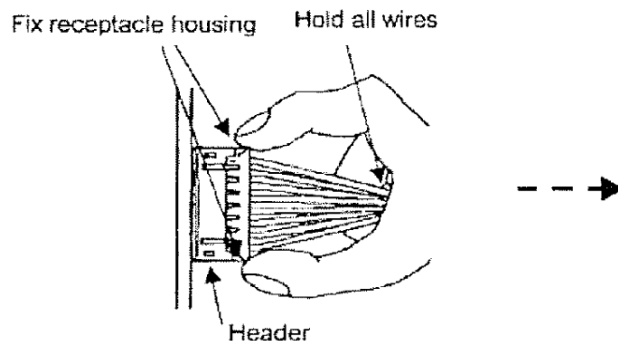

FIGURE 21. CONNECTOR REMOVAL

e. Routing of Wire

Route wire so as not to apply excessive force to connector; allow force to the extent that wire slightly buckles, considering enough length to route and fix wires.

7. External Fuse Rating

The fuse rating is 10 amperes for HWS300. Refer to this fuse rating when selecting the external fuses that are to be used on input line. Surge current flows when line turns on. Use slow-blow or time-lag type fuse, not fast-blow fuse. Fuse rating is specified by in-rush current value at line turn-on. Do not select the fuse according to input current (RMS.) values under the actual load condition.

8. Fan life expectancy

The Fan has a limited life. Therefore, periodic maintenance by replacing a life-expired fan is required for the power supply. Figure 22 shows the life of fan. The difference between the intake temperature and the exhaust temperature at $I_O = 100\%$ is 4°C for HWS300 Series.

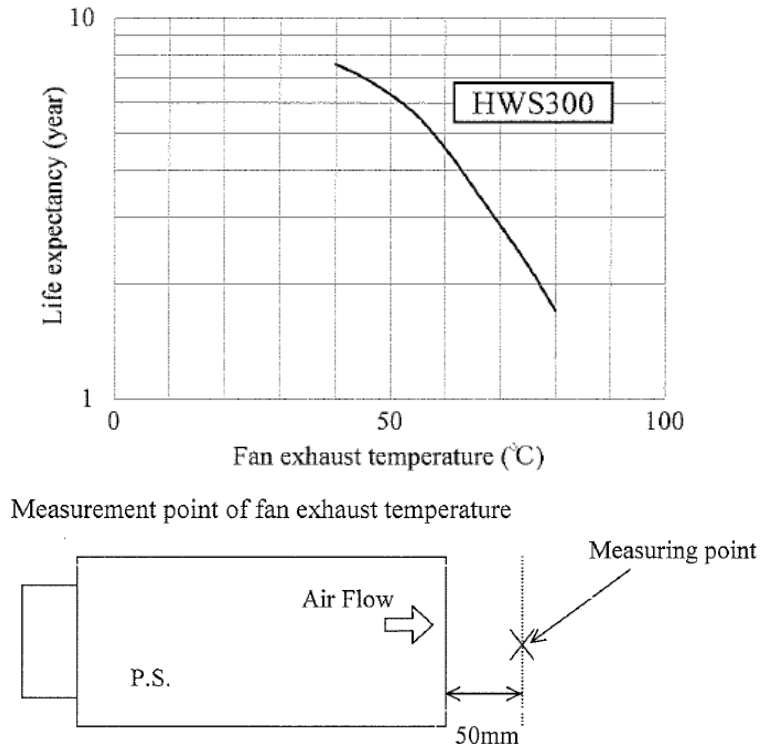

FIGURE 22. FAN LIFE EXPECTANCY

9. Troubleshooting

Before concluding that the unit is at fault, make the following checks.

1. Check if rated input voltage is connected.
2. Check if wiring of input and output is correct.
3. Check if I/O terminal connections are properly tightened using specified torque.
4. Check if wire thickness is adequate.
5. Check if the output voltage control (V.adj) is properly adjusted. If using external voltage or resistance for output voltage control, check that external resistance or voltage applied is within specification. OVP might be triggered causing the output to shut down.
6. If using Remote ON/OFF control, check that Remote ON/OFF control connector is not open. If in open condition, power supply will not supply an output.
7. Check if the built-in FAN is not stopped. If FAN stops, the PF signal goes to High level and OTP might be activated.
8. Power supply has ventilating holes on the front and back panels. Check for dust, blockage, etc.
9. Is the chassis of power supply abnormally hot? The output may be shut down by OTP (overtemperature) operation. Allow the unit to cool down sufficiently, then try again.
10. Check if the output current and output wattage are within specification.
11. Audible noise can be heard when input voltage waveform is not sinusoidal.
12. Audible noise can be heard during dynamic load operation.

10. Warranty

This product is warranted for a period of 3 years from the date of shipment. For breakdown under normal use during warranty term, repair is free of charge. However, there is a charge for replacement of the built-in FAN motor. Please contact our sales office for FAN replacement. Conditions of usage are as follows.

1. Average operating temperature (ambient temperature of the power supply unit) under 40°C
2. Average load factor is 80% or less.
3. Installation method: Standard installation. However, the maximum rating must be within the output derating.

The following cases are not covered by warranty.

1. Improper usage e.g., dropping of the product, applying shock, defects from exceeding unit specifications.
2. Defects resulting from natural disaster (fire, flood).
3. Unauthorized modifications or repair by the buyers.