

# OPERATOR'S MANUAL

## SERIES EL

### ELECTRONIC LOAD

KEPCO INC.  
An ISO 9001 Company.

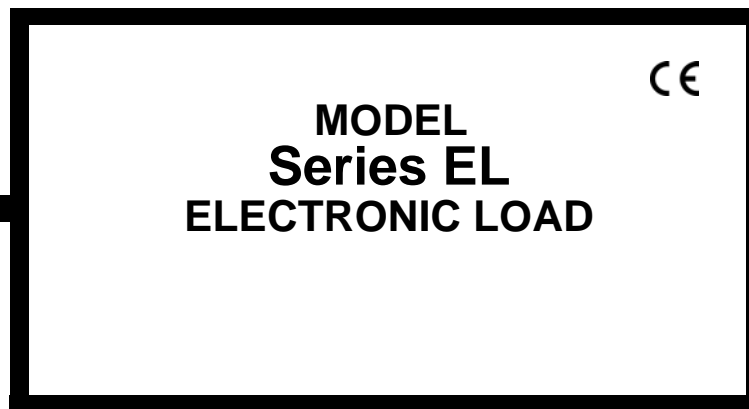

#### IMPORTANT NOTES:

- 1) This manual is valid for the following Firmware Versions:

FIRMWARE VERSION	UNIT REVISION NO.	NOTE
4.18 and higher		
- 2) A Change Page may be included at the end of the manual. All applicable changes and revision number changes are documented with reference to the equipment serial numbers. Before using this Instruction Manual, check your equipment firmware version number to identify your model. If in doubt, contact your nearest Kepco Representative, or the Kepco Documentation Office in New York, (718) 461-7000, requesting the correct revision for your particular model and firmware version number.
- 3) The contents of this manual are protected by copyright. Reproduction of any part can be made only with the specific written permission of Kepco, Inc.

Data subject to change without notice.

©2023, KEPCO, INC  
P/N 243-1295-r15



KEPCO, INC. • 131-38 SANFORD AVENUE • FLUSHING, NY. 11355 U.S.A. • TEL (718) 461-7000 • FAX (718) 767-1102  
email: [hq@kepcopower.com](mailto:hq@kepcopower.com) • World Wide Web: [www.kepcopower.com](http://www.kepcopower.com)



# TABLE OF CONTENTS

SECTION	PAGE
<b>SECTION 1 - INTRODUCTION</b>	
1.1	Scope of Manual..... 1-1
1.2	Introduction..... 1-1
1.3	General Description..... 1-3
1.4	Operating Modes..... 1-3
1.4.1	CI (Constant Current)..... 1-3
1.4.2	CV (Constant Voltage)..... 1-3
1.4.3	CP (Constant Power)..... 1-3
1.4.4	CR (Constant Resistance)..... 1-3
1.4.5	CS (Constant Conductance)..... 1-4
1.4.6	Short..... 1-4
1.4.7	Off..... 1-4
1.5	Features..... 1-4
1.5.1	Local Control..... 1-4
1.5.2	Remote Control..... 1-4
1.5.3	Analog Programming..... 1-4
1.5.4	Digital Calibration..... 1-4
1.5.5	Damping..... 1-5
1.5.6	Ramps..... 1-5
1.5.7	Input Cutoff..... 1-5
1.5.8	Transients..... 1-5
1.5.9	Built-in Protection..... 1-5
1.5.10	Master/Slave Control..... 1-5
1.6	Specifications..... 1-5
1.7	Equipment Supplied..... 1-7
1.8	Accessories..... 1-8
1.9	Options..... 1-8
1.10	Safety..... 1-8
<b>SECTION 2 - INSTALLATION</b>	
2.1	Unpacking and Inspection..... 2-1
2.2	Terminations and Controls..... 2-1
2.2.1	Front Panel Controls and Indicators..... 2-1
2.2.2	Rear Panel Connections..... 2-1
2.3	Mains Power Requirements..... 2-6
2.3.1	Changing Mains Power Voltage/Fuse replacement..... 2-6
2.4	Cooling..... 2-6
2.5	Installation..... 2-7
2.5.1	Rack Mounting..... 2-7
2.5.2	Slide Mounting..... 2-7
2.6	Wiring Instructions..... 2-7
2.6.1	Mains Power..... 2-8
2.6.2	Unit Under Test (UUT) to Load Connection..... 2-8
2.6.2.1	Power Connections..... 2-8
2.6.2.2	Sense Connections..... 2-9
2.6.2.3	Grounding..... 2-9
2.6.3	Parallel Master/Slave Configurations..... 2-10
2.6.4	Protective Cover Installation..... 2-12
2.6.5	Analog Control Connections..... 2-12
2.6.5.1	Non-Isolated (Hazardous) External Input (Fast)..... 2-12
2.6.5.2	Isolated External Input (SELV)..... 2-13
2.6.6	Current Monitor Connections..... 2-13
2.7	Digital Connections..... 2-13
2.7.1	Standard Units..... 2-13
2.7.2	G Option - GPIB Interface..... 2-13
2.7.3	E Option - Ethernet Interface..... 2-13

# TABLE OF CONTENTS

SECTION	PAGE
<b>SECTION 3 - OPERATION</b>	
3.1	General ..... 3-1
3.2	Factory Default Settings..... 3-1
3.3	Turning the Unit On..... 3-2
3.3.1	Error Conditions..... 3-2
3.4	Selecting the Mode and Setpoint ..... 3-3
3.5	Engaging the Load..... 3-4
3.6	Disengaging the Load ..... 3-4
3.7	Viewing Configuration Information ..... 3-4
3.8	Changing IP Mode ..... 3-5
3.9	Changing Static IP Address or Subnet Mask..... 3-5
3.10	Changing GPIB Address ..... 3-6
3.11	Operation of Master/slave Configurations..... 3-6
3.11.1	Power Up ..... 3-6
3.11.2	Local (Front Panel) Operation ..... 3-6
3.11.3	Remote (Computer) Operation ..... 3-6
3.11.4	Indications During Master/Slave Operation ..... 3-7
3.11.5	Master/Slave Controls and Indicators..... 3-7
3.11.6	Master/Slave Operating Notes/Cautions/Warnings ..... 3-7
3.11.7	Master/Slave Disconnect..... 3-8
3.12	Operation via Computer Interface..... 3-8
3.13	SCPI Programming..... 3-9
3.13.1	SCPI Messages..... 3-9
3.13.2	Common Commands/Queries ..... 3-9
3.13.3	SCPI Subsystem Command/Query Structure..... 3-12
3.13.3.1	DIAGNOSTIC Subsystem ..... 3-12
3.13.3.2	PROTection Subsystem ..... 3-13
3.13.3.3	[SOURce:]MEASure Subsystem ..... 3-13
3.13.3.4	[SOURce:]InPut, [SOURce:]OUTPut Subsystems ..... 3-13
3.13.3.5	[SOURce:]VOLTage, [SOURce:]CURRent, [SOURce:]POWer Subsystems..... 3-13
3.13.3.6	[SOURce:]Resistance, [SOURce:]CONDuctance Subsystems..... 3-13
3.13.3.7	STATus Subsystem..... 3-14
3.13.3.8	SYSTem subsystem..... 3-14
3.13.4	Program Message Structure..... 3-15
3.13.4.1	Keyword..... 3-15
3.13.4.2	Keyword Separator..... 3-15
3.13.4.3	Query Indicator ..... 3-15
3.13.4.4	Data ..... 3-15
3.13.4.4.1	Multiple Line Messages..... 3-15
3.13.4.5	Data Separator ..... 3-15
3.13.4.6	Message Terminator..... 3-16
3.13.5	Understanding The Command Structure..... 3-16
3.13.6	Program Message Syntax Summary ..... 3-17
3.13.7	Status Reporting..... 3-17
3.13.7.1	Status Reporting Structure ..... 3-17
3.13.7.2	Standard Event Status Register ..... 3-17
3.13.7.3	QUEStionable Status Register ..... 3-19
3.13.7.4	Channel Status Register..... 3-19
3.13.7.5	Channel Summary Register ..... 3-20
3.13.7.6	Status Byte Register..... 3-20
3.14	Damping..... 3-20
3.14.1	Damping Adjustments..... 3-21
3.14.2	Recommended Damping Adjustment Procedure ..... 3-21
3.14.3	Damping Procedure using Front Panel Controls ..... 3-23
3.15	Programming Time Required to Change State (Ramps) ..... 3-23
3.15.1	Ramp Details ..... 3-24

# TABLE OF CONTENTS

SECTION	PAGE
3.15.2 Ramp Interactions .....	3-25
3.15.3 Accessing Ramps from the Front Panel .....	3-25
3.16 Minimum Input Voltage .....	3-26
3.16.1 Programming Minimum Input Voltage from the Front Panel .....	3-26
3.17 Analog Programming .....	3-27
3.18 Operator Maintenance .....	3-27

## APPENDIX A - IEEE 488.2 COMMAND/QUERY DEFINITIONS

A.1 Introduction .....	A-1
A.2 *CLS — Clear Status Command .....	A-1
A.3 *ESE — Standard Event Status Enable Command .....	A-1
A.4 *ESE? — Standard Event Status Enable Query .....	A-2
A.5 *ESR? — Event Status Register Query .....	A-2
A.6 *IDN? — Identification Query .....	A-2
A.7 *RST — Reset Command .....	A-3
A.8 *SRE — Service Request Enable Command .....	A-3
A.9 *SRE? — Service Request Enable Query .....	A-4
A.10 *STB? — Status Byte Register Query .....	A-4
A.11 *WAI — Wait Command .....	A-4

## APPENDIX B - SCPI COMMAND/QUERY DEFINITIONS

B.1 Introduction .....	B-1
B.2 Numerical Values and Data Conventions .....	B-2
B.3 DIAGnostic:RESet Command .....	B-2
B.4 DIAGnostic:TREE:DISPlay Command .....	B-2
B.5 DIAGnostic:TREE:SEParator Command .....	B-3
B.6 DIAGnostic:TREE:SEParator? Query .....	B-3
B.7 LOCK Command .....	B-3
B.8 LOCK? Query .....	B-3
B.9 [SOURce:]INPut[:STATe] Command .....	B-3
B.10 [SOURce:]INPut[:STATe]? Query .....	B-3
B.11 [SOURce:]INPut:CUToff:TIME Command .....	B-3
B.12 [SOURce:]INPut:CUToff:TIME? Query .....	B-4
B.13 [SOURce:]INPut:CUToff:VOLTage Command .....	B-4
B.14 [SOURce:]INPut:CUToff:VOLT? Query .....	B-4
B.15 INPut:RAMP Command .....	B-4
B.16 INPut:RAMP? Query .....	B-5
B.17 [SOURce:]INPut:PROTection:CLEar Command .....	B-5
B.18 [SOURce:]INPut:PROTection:SHORT[:STATe] Command .....	B-5
B.19 [SOURce:]OUTPut[:STATe] Command .....	B-5
B.20 [SOURce:]OUTPut[:STATe]? Query .....	B-5
B.21 [SOURce:]OUTPut:PROTection:CLEar Command .....	B-5
B.22 [SOURce:]OUTPut:PROTection:SHORT[:STATe] Command .....	B-5
B.23 [SOURce:]MEASure:ALL? Query .....	B-6
B.24 [SOURce:]MEASure:ALL2? Query .....	B-6
B.25 [SOURce:]MEASure[:SCALar]:CURRent[:DC]? Query .....	B-6
B.26 [SOURce:]MEASure[:SCALar]:POWer[:DC]? Query .....	B-6
B.27 [SOURce:]MEASure[:SCALar]:VOLTage[:DC]? Query .....	B-6
B.28 [SOURce:]CONDUCTance[:LEVel][:IMMediate][:AMPLitude] Command .....	B-6
B.29 [SOURce:]CONDUCTance[:LEVel][:IMMediate][:AMPLitude]? Query .....	B-6
B.30 [SOURce:]CONDUCTance:TRANSient Command .....	B-7
B.31 [SOURce:]CONDUCTance:TRANSient? Query .....	B-7
B.32 [SOURce:]CURRent[:LEVel][:IMMediate][:AMPLitude] Command .....	B-7

# TABLE OF CONTENTS

SECTION		PAGE
B.33	[SOURce:]CURRent[:LEVel][:IMMediate][:AMPlitude]? Query .....	B-7
B.34	[SOURce:]CURRent:PROTection[:LEVel] Command .....	B-7
B.35	[SOURce:]CURRent:PROTection[:LEVel]? Query .....	B-7
B.36	[SOURce:]CURRent:PROTection:STATe Command .....	B-8
B.37	[SOURce:]CURRent:PROTection:STATe? Query .....	B-8
B.38	[SOURce:]CURRent:TRANSient Command .....	B-8
B.39	[SOURce:]CURRent:TRANSient? Query .....	B-8
B.40	[SOURce:]MODE Command .....	B-8
B.41	[SOURce:]MODE? Query .....	B-8
B.42	[SOURce:]POWer[:LEVel][:IMMediate][:AMPlitude] Command .....	B-8
B.43	[SOURce:]POWer[:LEVel][:IMMediate][:AMPlitude]? Query .....	B-9
B.44	[SOURce:]POWer:PROTection Command .....	B-9
B.45	[SOURce:]POWer:PROTection? Query .....	B-9
B.46	[SOURce:]POWer:PROTection:STATe[:LEVel] Command .....	B-9
B.47	[SOURce:]POWer:PROTection:STATe[:LEVel]? Query .....	B-9
B.48	[SOURce:]RESistance[:LEVel][:IMMediate][:AMPlitude] Command .....	B-9
B.49	[SOURce:]RESistance[:LEVel][:IMMediate][:AMPlitude]? Query .....	B-9
B.50	[SOURce:]RESistance:TRANSient Command .....	B-10
B.51	[SOURce:]RESistance:TRANSient? Query .....	B-10
B.52	[SOURce:]VOLTage[:LEVel][:IMMediate][:AMPlitude] Command .....	B-10
B.53	[SOURce:]VOLTage[:LEVel][:IMMediate][:AMPlitude]? Query .....	B-10
B.54	[SOURce:]VOLTage:PROTection:OVER Command .....	B-10
B.55	[SOURce:]VOLTage:PROTection:OVER? Query .....	B-10
B.56	[SOURce:]VOLTage:PROTection:OVER:STATe[:LEVel] Command .....	B-10
B.57	[SOURce:]VOLTage:PROTection:OVER:STATe[:LEVel]? Command .....	B-11
B.58	[SOURce:]VOLTage:PROTection:UNDer Command .....	B-11
B.59	[SOURce:]VOLTage:PROTection:UNDer? Query .....	B-11
B.60	[SOURce:]VOLTage:PROTection:UNDer:STATe[:LEVel] Command .....	B-11
B.61	[SOURce:]VOLTage:PROTection:UNDer:STATe[:LEVel]? Query .....	B-11
B.62	[SOURce:]VOLTage:TRANSient Command .....	B-11
B.63	[SOURce:]VOLTage:TRANSient? Query .....	B-12
B.64	STATus:CHANnel[:EVENT]? Query .....	B-12
B.65	STATus:CHANnel:CONDition Command .....	B-12
B.66	STATus:CHANnel:CONDition? Query .....	B-12
B.67	STATus:CHANnel:ENABle Command .....	B-12
B.68	STATus:CHANnel:ENABle? Query .....	B-12
B.69	STATus:CSUMmary[:EVENT]? Query .....	B-13
B.70	STATus:CSUMmary:ENABle COMMAND .....	B-13
B.71	STATus:CSUMmary:ENABle? Query .....	B-13
B.72	STATus:OPERation[:EVENT]? Query .....	B-13
B.73	STATus:OPERation:CONDition? Query .....	B-13
B.74	STATus:OPERation:ENABle Command .....	B-14
B.75	STATus:OPERation:ENABle? Query .....	B-14
B.76	STATus:OPERation:NTRANSition Command .....	B-14
B.77	STATus:OPERation:PTRansition Command .....	B-14
B.78	STATus:QUEStionable[:EVENT]? Query .....	B-14
B.79	STATus:QUEStionable:CONDition? Query .....	B-14
B.80	STATus:QUEStionable:ENABle Command .....	B-14
B.81	STATus:QUEStionable:ENABle? Query .....	B-15
B.82	SYSTem:COMMunicate[:GPIB]:ADDress Command .....	B-15
B.83	SYSTem:COMMunicate[:GPIB]:ADDress? Query .....	B-15
B.84	SYSTem:COMMunicate:ECHO Command .....	B-15
B.85	SYSTem:COMMunicate:ECHO? Query .....	B-15
B.86	SYSTem:COMMunicate:LAN:IPADdress Command .....	B-15
B.87	SYSTem:COMMunicate:LAN:IPADdress? Query .....	B-15
B.88	SYSTem:COMMunicate:LAN:MAC? Query .....	B-16
B.89	SYSTem:COMMunicate:LAN:MODE Command .....	B-16

# TABLE OF CONTENTS

SECTION		PAGE
B.90	SYSTem:COMMunicate:LAN:MODE? Query .....	B-16
B.91	SYSTem:COMMunicate:LAN:SUBNetmask Command.....	B-16
B.92	SYSTem:COMMunicate:LAN:SUBNetmask? Query .....	B-16
B.93	SYSTem:DAMPing COMMAND.....	B-16
B.94	SYSTem:DAMPing? Query.....	B-17
B.95	SYSTem:ERRor? Query .....	B-17
B.96	SYSTem:EXTernal COMMAND .....	B-17
B.97	SYSTem:EXTernal? Query .....	B-17
B.98	SYSTem:FAN COMMAND.....	B-17
B.99	SYSTem:FAN? Query.....	B-17
B.100	SYSTem:MODE COMMAND .....	B-18
B.101	SYSTem:MODE? Query .....	B-18
B.102	SYSTem:PFModule:DAMPing COMMAND .....	B-19
B.103	SYSTem:PFModule:DAMPing? Query .....	B-19
B.104	SYSTem:PFModule:LIST? Query .....	B-19
B.105	SYSTem:PFModule:STATus? Query.....	B-20
B.106	SYSTem:RAMP COMMAND .....	B-21
B.107	SYSTem:RAMP? Query.....	B-21
B.108	SYSTem:RAMP:POSitive COMMAND .....	B-21
B.109	SYSTem:RAMP:POSitive? Query.....	B-21
B.110	SYSTem:RAMP:NEGative COMMAND .....	B-21
B.111	SYSTem:RAMP:NEGative? Query .....	B-21
B.112	SYSTem:RANGe:CURRent COMMAND .....	B-22
B.113	SYSTem:RANGe:CURRent? Query .....	B-22
B.114	SYSTem:RANGe:POWer COMMAND.....	B-22
B.115	SYSTem:RANGe:POWer? Query.....	B-22
B.116	SYSTem:Range:VOLTage COMMAND .....	B-22
B.117	SYSTem:Range:VOLTage? Query .....	B-22
B.118	SYSTem:REPLY COMMAND .....	B-22
B.119	SYSTem:REPLY? Query .....	B-23
B.120	SYSTem:SERNumber? Query.....	B-23
B.121	SYSTem:SETTings? Query .....	B-23
B.122	SYSTem:VERSion? QUERY .....	B-23

# LIST OF FIGURES

FIGURE	TITLE	PAGE
1-1	Series EL Load.....	viii
2-1	7-Segment Display Characters .....	2-1
2-2	Series EL, Front Panel Controls and Indicators .....	2-2
2-3	Series EL, Dual Model Front Panel Controls and Indicators .....	2-2
2-4	Series EL, Rear Panel Terminations and Connectors.....	2-4
2-5	Series EL, Dual Output Models, Rear Panel Terminations and Connectors.....	2-4
2-6	Typical Interconnections.....	2-8
2-7	Typical Master/Slave Interconnections.....	2-11
2-8	Protective Cover Installation, Single Output Model (Typical) .....	2-12
2-9	EL Load, Outline Dimension Drawing .....	2-14
2-10	EL Load, Dual-Channel, Outline Dimension Drawing .....	2-16
3-1	Example of Remote Operation .....	3-8
3-2	Master/Slave Start-up, Computer Display .....	3-10
3-3	Tree Diagram of SCPI Commands Used with Series EL Electronic Load .....	3-14
3-4	Status Reporting Structure .....	3-18
3-5	Damping Measurement Setup.....	3-21
3-6	Damping Waveforms.....	3-22
3-7	Timing for Programming INPT Ramp and Minimum Voltage .....	3-24
B-1	Ramp and Transient Timing .....	B-18



# LIST OF TABLES

TABLE	TITLE	PAGE
1-1	Model Parameters .....	1-2
1-2	Series EL Specifications .....	1-6
1-3	Mode Characteristics .....	1-7
1-4	Equipment Supplied .....	1-7
1-5	Accessories .....	1-8
1-6	Safety Symbols .....	1-8
2-1	Front Panel Functions .....	2-2
2-2	Rear Panel Connections .....	2-5
2-3	Analog Control and RS -232 Port Pin assignments .....	2-6
3-1	Mode Selection and Adjustments .....	3-3
3-2	Remote Operation Command Summary .....	3-12
A-1	IEEE 488.2 Command/query Index .....	A-1
A-2	Standard Event Status Enable Register and Standard Event Status Register Bits .....	A-1
A-3	Service Request Enable and Status Byte Register Bits .....	A-4
B-1	SCPI Subsystem Command/query Index .....	B-1
B-2	Channel Status Condition, Enable, and Event Register Bits .....	B-12
B-3	Channel Summary Enable and Event Register Bits .....	B-13
B-4	Operation Condition Register, Operation Enable Register, and Operation Event Register Bits .....	B-13



Model EL 2K-200-200  
Single Input Unit



Model EL 1K-200-100D  
Dual Input Unit

FIGURE 1-1. SERIES EL LOAD

## SECTION 1 - INTRODUCTION

### 1.1 SCOPE OF MANUAL

This manual contains instructions for the installation, operation and service of the Series EL Electronic loads manufactured by KEPCO, Inc., Flushing, New York, U.S.A., and applies to units with Firmware Version and Unit Revision number indicated on the Title page. Firmware Version is obtained in the response to \*IDN? query. The Unit Revision number is visible on the side of the unit, directly behind the top left side of the front panel (looking from the front).



#### WARNING

**DANGEROUS AND LETHAL POTENTIALS AND CURRENTS ARE PRESENT, BOTH WITHIN THIS ELECTRONIC LOAD, AND AT THE INPUT AND SENSE TERMINAL BLOCKS!**

**Before proceeding to use the electronic load, read this manual very carefully. Caution must be used when working with, and making connections to, this load. Use only wires with the proper current rating and proper voltage rating for high voltage connections.**



#### CAUTION!

**Do not close a switch (mechanical, relay contact or electronic) between the UUT power source and the enabled Series EL load. Always connect the UUT to EL and enable them when needed. Closing the circuit between an enabled voltage source UUT and an enabled EL will discharge the voltage source output capacitors into the saturated EL power MOSFETS before EL control can limit the current. This may damage both the EL and the UUT.**



#### CAUTION!

**Never open the connection between the Series EL load and UUT while the load is enabled and current is flowing. Always disable Series EL load and/or UUT power source output first. Arcing may damage either the UUT or the EL Series load.**



#### CAUTION!

**Never power down the Series EL load while the load is enabled and current is flowing. Always disable Series EL load and/or UUT power source first. Otherwise damage to the EL Series load is likely to occur.**

### 1.2 INTRODUCTION

The Series EL Electronic Loads (Figure 1-1) are modular, air-cooled, electronic loads. Typically these loads are used to test DC power sources, such as batteries, power supplies, generators, chargers, fuel cells etc.

Table 1-1 lists the rated power, voltage and current for Kepco's Series EL electronic loads. For example. Kepco Model 3K-600-90 Electronic Load uses 1000-volt devices allowing 600 volt operation and is rated at a maximum current capability of 90 amperes and a power rating of 3000 Watts.

Model numbers with a D suffix indicate a dual-channel load. These models are comprised of two identical independent loads within a single chassis.

**TABLE 1-1. MODEL PARAMETERS**

Model number	Operating Limits			Overload Protection <sup>(1)</sup>			Minimum On Resistance All Modes (Ohms)
	Rated Power (Watts)	Rated Voltage (Volts)	Rated Current Max (any Mode) (Amperes)	Power <sup>(2)</sup> (Watts)	Voltage <sup>(3)</sup> (Volts)	Current <sup>(2)(4)</sup> (Amps)	
EL 1K-50-125, D <sup>(5)</sup>	1000	50	125	1050	52.5	135	0.008
EL 1K-200-100, D <sup>(5)</sup>	1000	200	100	1050	210	105	0.014
EL 1K-400-70, D <sup>(5)</sup>	1000	400	70	1050	420	73.5	0.046
EL 1K-600-30, D <sup>(5)</sup>	1000	600	30	1050	630	31.5	0.017
EL 2K-50-250, D <sup>(5)</sup>	2000	50	250	2100	52.5	265	0.004
EL 2K-200-200, D <sup>(5)</sup>	2000	200	200	2100	210	210	0.007
EL 2K-400-140, D <sup>(5)</sup>	2000	400	140	2100	420	147	0.023
EL 2K-600-60, D <sup>(5)</sup>	2000	600	60	2100	630	63	0.083
EL 3K-25-400D <sup>(5)(6)</sup>	3000	50	400	2400	52.5	420	0.004
EL 3K-50-400	3000	50	400	3150	52.5	420	0.005
EL 3K-200-300	3000	200	300	3150	210	315	0.005
EL 3K-400-210	3000	400	210	3150	420	220.5	0.015
EL 3K-600-90	3000	600	90	3150	630	94.5	0.056
EL 4K-50-600	4000	50	600	4200	52.5	630	0.002
EL 4K-200-500	4000	200	500	4200	210	525	0.003
EL 4K-400-350	4000	400	350	4200	420	367.5	0.009
EL 4K-600-150	4000	600	150	4200	630	157.5	0.033
EL 5K-50-800	5000	50	800	5250	52.5	835	0.002
EL 5K-200-600	5000	200	600	5250	210	630	0.002
EL 5K-400-420	5000	400	420	5250	420	441	0.008
EL 5K-600-200	5000	600	200	5250	630	210	0.028

NOTES:

- (1) Temperature protection: Per FET safe junction temperature.
- (2) Maximum operating power and current may be reduced if a) ambient temperature exceeds 25°C or b) operating conditions (ambient temperature, available air flow, etc.) cause internal load temperature to exceed safe operating conditions for FETs (temperature fault).
- (3) Maximum permissible voltage across ±LOAD terminals. This voltage should never be exceeded, regardless of load power or load on/off states. Applied voltage must always be positive: +LOAD with respect to –LOAD.
- (4) Each FET is individually fused. A blown fuse is reported as a Fault.
- (5) D indicates model is also available as a Dual model. Dual models (D suffix) contain two identical and independent channels in a single chassis; specifications listed are per channel for dual models.
- (6) EL 3K-25-400D only available as dual model,

### 1.3 GENERAL DESCRIPTION

The Series EL load system is comprised of two elements—the load and a control source. The load dissipates power from the UUT—i.e. the source of electrical energy being tested by the load. The source of control is either the load front panel or an external computer or other device that can communicate using the interface protocols for which the Series EL is configured.

The load is rack-mountable. Local front panel control allows mode selection and provides: mode indications; display of load current, voltage and power measurements; control parameter adjustment; local/remote control status; fault indications; and power on/off control of the load.

The load has high-current rear panel LOAD Terminals used to connect the UUT to the load, analog control and monitoring terminals, master/slave communications connections, USB 2.0 and RS-232 connectors for remote control, and a mains power connector with fuse. The load can also be configured with optional Ethernet or GPIB interfaces.

Values of load current, voltage and power, as well as fault information can be reported to a computer for display and analysis. SCPI-compliant commands transmitted to the load set the load operating parameters. Special commands allow the user to configure the load measurement system and to perform diagnostic tests.

Series EL electronic loads are designed for future expandability to accommodate increased testing needs as user requirements grow. Any EL electronic load can be expanded to a full 5 kW capability (with a commensurate increase in maximum current carrying capacity). Additionally, the Series EL system can be expanded above the power/current limits defined in Table 1-1 by adding up to 14 additional loads. These slave loads act in concert with a master load to increase total power dissipation (and current handling).

### 1.4 OPERATING MODES

The load operates in one of six modes. Each mode is subject to independent limits for maximum load current, power, voltage and frequency. Current draw does not occur until the load is turned ON (engaged with) the Unit Under Test (UUT).

#### 1.4.1 CI (CONSTANT CURRENT).

The current drawn by the load from the UUT remains at a constant value defined by the user.

#### 1.4.2 CV (CONSTANT VOLTAGE)

The current drawn by the load from the UUT varies as required to cause the UUT voltage to decrease to the voltage defined by the user. Operation in CV mode requires sufficient source resistance in the UUT so voltage drops in the UUT allow the desired voltage control.

#### 1.4.3 CP (CONSTANT POWER)

The current drawn by the load from the UUT varies as required to cause a constant amount of power defined by the user to be dissipated by the load, where power is defined as the product of UUT voltage and current drawn by the load.

#### 1.4.4 CR (CONSTANT RESISTANCE)

The current drawn by the load from the UUT varies as required to cause a constant resistance (UUT voltage divided by load current) defined by the user.

#### 1.4.5 CS (CONSTANT CONDUCTANCE)

The current drawn by the load from the UUT varies as required to cause a constant conductance (UUT current divided by load voltage) defined by the user.

#### 1.4.6 SHORT

The current drawn by the load is the maximum possible by the load; load resistance is minimum ON (see Table 1-2). **CAUTION: There is no user adjustment of the current in the SHORT mode—use caution!**

#### 1.4.7 OFF

No current is drawn by the load even when the load is turned ON.

### 1.5 FEATURES

#### 1.5.1 LOCAL CONTROL

Three 4-digit, 7-segment LED displays and six individual LEDs on the front panel show operating status. A rotary encoder (CONTROL) allows the user to adjust the selected load parameter, define the resolution of the rotary encoder and to select the operating mode. An illuminated momentary pushbutton switch (LOAD) allows the user to alternately a) engage the load, allowing the source or Unit Under Test (UUT) to draw current and b) disengage the load, stopping current flow. An integral indicator within the LOAD switch changes color to show the load connection status and indicate a fault condition if one exists.

#### 1.5.2 REMOTE CONTROL

Remote control of the Series EL Electronic Load is accomplished from a remote device using SCPI commands and either RS-232 or USB protocols. GPIB (G suffix) or LAN (E suffix) protocols are available as an option. The RS-232 and USB ports cannot be turned off, therefore the Series EL can always be controlled via these ports. Digital commands expand the control available from the front panel, and include damping when required for square wave or pulse type requirements, overvoltage, undervoltage, overcurrent and overpower protections.

#### 1.5.3 ANALOG PROGRAMMING

Two analog control ports are provided. A non-isolated (hazardous) input external control and an isolated input analog control (see PAR. 2.6.5 for details). The non-isolated input provides for a fast transient capability of 20 microseconds which can eliminate undesired transients that may occur at the load when going from off to on. The isolated analog control input has a transient capability of 60 microseconds. The transient capability is affected by damping of the EL. Analog programming is summed with the digital setpoint to allow a waveform to ride on a d-c level. Refer to PAR. 3.17 for details.

#### 1.5.4 DIGITAL CALIBRATION

Internal adjustments of the Series EL Electronic Load are automatic. Calibration can be performed remotely via one of the remote interfaces.

### **1.5.5 DAMPING**

Typical operation for an electronic load involves the flow of high currents. The combination of high, rapidly changing currents and the inductance associated with connections to the load via lead wires can cause unexpected results, such as very high voltage spikes, oscillation or severe ringing (damped oscillations) at the source. To help reduce these issues, the Series EL offers multiple forms and degrees of damping, allowing the best measurements possible. See PAR. 3.14 for details.

### **1.5.6 RAMPS**

Three independently adjustable ramps allow the user to ease the transition when changing to 1) a more positive state, 2) a more negative state, and 3) reaching operating mode setpoint after engaging the load. See PAR. 3.15 for details.

### **1.5.7 INPUT CUTOFF**

The input cutoff feature allows the user to determine a minimum input voltage required for engaging the load. This feature also allows the user to adjust the time the unit will wait for input voltage to recover if it falls below the minimum. See PAR's B.11 and B.13 for details.

### **1.5.8 TRANSIENTS**

The EL Load allows the user to inject a transient into the unit under test. Transients are available in voltage, current, conductance or resistance modes, and can be single or repeating. User-controllable transient parameters are maximum value, time duration, pulse-width and (for repeating transients), the period. See PAR. B.100 for details.

### **1.5.9 BUILT-IN PROTECTION**

- **Overtemperature.** Thermal management of the EL Series is accomplished by continually monitoring the temperature of each individual power-dissipating MOSFET. If the temperature of a MOSFET begins to approach a dangerous level, then its power will be reduced and the other MOSFETs will naturally increase their share via the control loops. If the temperature of one or more of the MOSFETs exceeds safe operating limits, this may cause either a reduction of the load maximum current/power handling ability or a complete inability to use the load depending on the degree of overheating.
- The user can establish limits for overvoltage or undervoltage, overcurrent, or power which can not be exceeded at the input. If the limits are exceeded, the unit disengages from the UUT and a fault indication is displayed (see PAR. 3.3.1 for details).

### **1.5.10 MASTER/SLAVE CONTROL**

For configurations that require power or current in excess of the maximum available from a single unit, additional units can be added to the system to increase power/current capability, up to a maximum of 14 additional units.

## **1.6 SPECIFICATIONS**

Parameters unique to different models of Series EL loads are listed in Table 1-1. Specifications common to all Series EL models are listed in Table 1-2.

**TABLE 1-2. SERIES EL SPECIFICATIONS**

SPECIFICATION	RATING/DESCRIPTION	CONDITION/COMMENT
<b>MODE CHARACTERISTICS</b>		
Linearity vs. programming command	See Table 1-3	5 – 100%; accuracy is % of Full Scale value <sup>(2)</sup>
Regulation <sup>(1)</sup>	See Table 1-3	5 – 100%; regulation is % of Full Scale value <sup>(2)</sup>
Resolution (via computer control)	14 Bits	5 – 100% of Full Scale
Current readback (Current mode)	Computer Accuracy:	±0.25%
	Computer Resolution:	±16 Bits
Parameter readback (Current and Voltage)	Accuracy:	±0.25% (±1% for 50V models)
	Resolution:	±16 Bits
	Temperature coefficient:	100 ppm/°C
<b>CONTROL CHARACTERISTICS</b>		
USB Interface	Uses IEEE 488.2 and SCPI commands and queries.	Requires driver.
RS-232 Interface	Uses IEEE 488.2 and SCPI commands and queries.	Baud rate: 38400 Parity: None Data Bits: 8 Stop Bits: 1 Flow Control: None
GPIB Interface	Uses IEEE 488.2 and SCPI commands and queries.	Optional. GPIB address 10 = default
Ethernet Interface	Uses IEEE 488.2 and SCPI commands and queries.	Optional.
<b>INPUT IMPEDANCE</b>		
EL 50V Models	80K Ohms	
EL 200V Models	160K Ohms	
EL 400V Models	200K Ohms	
EL 600V Models	320K Ohms	
<b>GENERAL CHARACTERISTICS</b>		
a-c Line Power Input	120-240 V a-c, 50/60 Hz, 200W	Range: 108-264V a-c
Electromagnetic compatibility	Emissions	CISPR11, Class A
	Immunity	EN 61326-1, Table 2 Industrial Environment
Cooling	Forced Air (400 CFM)	Six fans, cooling (number of fans operating) determined by load demand.
Operating Temperature	0°C to 40°C	
Dimensions (load)	19"W x 7"H x 24.5"D	See Figure 2-9.
Weight (load)	76 lbs.	90 lbs packed for shipment
Storage Requirements	-20 to +60°C, 15 to 80% RH	Relatively dust free environment.

NOTES:

(1) Regulation specified after 15 minutes of operation at set power level. (2) Accuracy and regulation are valid from 5% to 100% of the rated value. The accuracy (e.g., ±0.25% of a constant current setpoint) is ±0.25% of the full scale value and not the setpoint.

(3) For 240V configuration of dual-channel models, contact Kepco.



**TABLE 1-3. MODE CHARACTERISTICS**

MODE	Linearity Vs. Programming Command	Regulation (1)
Constant Current	±0.25%	±0.25%
Constant Power	±2%	±1%
Constant Voltage	±0.25% (±1% for 50V models)	±0.25%
Constant Resistance	±1%	±1%
Constant Conductance	±1%	±1%

(1) Regulation specified after 15 minutes of operation at set power level

## 1.7 EQUIPMENT SUPPLIED

Equipment supplied with the unit is listed in Table 1-4.

**TABLE 1-4. EQUIPMENT SUPPLIED**

ITEM	PART NUMBER	QUANTITY
		1
Series EL Quick Start Guide *	228-1687	1
EL Series (except Dual models) ±LOAD terminal hardware		
Nut, Hex, silicon bronze, 3/8-16	102-0182	2
Washer, split, silicon bronze, 3/8	103-0198	2
Washer, flat, silicon bronze, 3/8	103-0197	4
Screw, Hex, 3/8-16 x 1 in.	101-0507	2
EL Series Dual models ±LOAD terminal hardware		
Nut, Hex, silicon bronze, 3/8-16	102-0182	4
Washer, split, silicon bronze, 3/8	103-0198	4
Washer, flat, silicon bronze, 3/8	103-0197	8
Screw, Hex, 3/8-16 x 1 in.	101-0507	4
Ground stud hardware		
Wingnut, 1/4-20, 18-8 stainless-steel	102-0190	1
Washer, Flat, 1/4 in., 18-8 stainless-steel	103-0201	2
Washer, split, 1/4 in., 18-8 stainless-steel	103-0204	1
Nut, 1/4-20, 18-8 stainless-steel	102-0188	1
Fuse 3.15A, SB (installed in fuseholder above a-c inlet connector on rear panel.)	141-0137 (Littelfuse 2183.15HXP)	2
Protective Cover: 200V, 400V, 600V Models (Single Chassis only)		
Metal Cover (metal)	129-0421	1
Clear Lexan Cover (covers top of metal cover)	137-0153	1
SEM Screws (two attaching metal cover to chassis, two attaching clear cover to metal cover)	101-0520	4
Protective Cover: 200V, 400V, 600V Models (Dual Chassis only)		
Metal Cover (metal)	129-0422	1
Clear Lexan Cover (covers top of metal cover)	137-0154	1
SEM Screws (two attaching metal cover to chassis, three attaching clear cover to metal cover.)	101-0520	5
* Series EL USB Driver Manual and Series EL Operator Manual are available for free download from the Kepco website at <a href="http://www.kepcopower.com/support/opmanls.htm#e">www.kepcopower.com/support/opmanls.htm#e</a> Series EL Drivers are available for free download at <a href="http://www.kepcopower.com/drivers/drivers-dl3.htm#el">www.kepcopower.com/drivers/drivers-dl3.htm#el</a>		

## 1.8 ACCESSORIES

Accessories for the Series EL Electronic Load are listed in Table 1-5.

## 1.9 OPTIONS

The G option (suffix G added to model number) includes the GPIB interface. For single units the GPIB interface is in addition to the standard RS-232 and USB interfaces. For dual units the GPIB interface replaces the standard RS-232 and USB interfaces.

The E Option (suffix E added to model number) includes the Ethernet (LAN) interface in addition to the standard RS-232 and USB interfaces.

Dual Channel models are identified by a D Suffix. These models contain two identical independent loads in one chassis.



## 1.10 SAFETY

There are no operator serviceable parts inside the case. Service must be referred to authorized personnel. Using the load in a manner not specified by Kepco, Inc. may impair the protection provided by the load. Observe all safety precautions noted throughout this manual. Table 1-6 lists symbols used on the electronic load or in this manual where applicable.

**TABLE 1-5. ACCESSORIES**

ITEM	FUNCTION	KEPCO PART NUMBER
Source Power cable	Connects IEC 320-style power inlet connector with integral fuse holder to 115V a-c via molded US line cord using 18AWG three conductor jacketed cable with an insulation rating of 300 Volts for 115VAC input voltage with polarized mating plug: 3 Amperes, 1 meter long.	118-1234 (Unicable 3850-761-BB/G)
RJ 22 Master/Slave cable, 1 ft.	Daisy chains Series EL loads with the same voltage for parallel configurations.	118-1245
RJ 22 Master/Slave cable, 2 ft.	Daisy chains Series EL loads with the same voltage for parallel configurations.	118-1454
Fuse 2.5A, SB (2)	Two (2) required for units configured to run from a-c source power above 200V a-c.	141-0136 (Littelfuse 21802.5HXP)
Slides (pair)	Allows the unit to slide out of a rack. see PAR. 2.5.2.)	CS 06
Side Support bracket	Pair required. Used to provide side support for EL Load. Requires rear rail at 18-13/16 in. setback.	128-1775

**TABLE 1-6. SAFETY SYMBOLS**

SYMBOL	MEANING
	CAUTION: RISK OF ELECTRIC SHOCK.
	CAUTION: REFER TO REFERENCED PROCEDURE.
WARNING	INDICATES THE POSSIBILITY OF BODILY INJURY OR DEATH.
CAUTION	INDICATES THE POSSIBILITY OF EQUIPMENT DAMAGE.

## SECTION 2 - INSTALLATION

### 2.1 UNPACKING AND INSPECTION

This instrument has been thoroughly inspected and tested prior to packing and is ready for operation. After careful unpacking, inspect for shipping damage before attempting to operate. Perform the preliminary operational check as outlined in PAR 2.5. If any indication of damage is found, file an immediate claim with the responsible transport service.



### CAUTION!

**An oversized cardboard box, rated 500 lbs. or greater, is required to ship the unit. The box must exceed the dimensions of the unit by 3" on each side (front, back, left and right) and 1.5" top and bottom with hard foam securing the EL. This hard foam prevents movement of the unit within the box. InstaPak (spray in foam) is NOT adequate to secure this unit.**

### 2.2 TERMINATIONS AND CONTROLS

**2.2.1 FRONT PANEL CONTROLS AND INDICATORS.** Three 4-digit, 7-segment LED displays and six individual LEDs on the front panel show operating status as shown in Figure 2-2 or Figure 2-3. Figure 2-1 shows the conventions used for displaying alphanumeric characters on the 7-segment displays. A rotary encoder (CONTROL) allows the user to: a) adjust the selected load parameter, b) define the resolution of the rotary encoder, c) select the operating mode. A momentary pushbutton switch (LOAD) with integral LED indicator allows the user to alternately a) engage the load, allowing the source or Unit Under Test (UUT) to draw current and b) disengage the load, stopping current flow. The LOAD LED indicator colors show the load connection status and indicate a fault condition if one exists.

0 → 0	R → A	P → K	U → U
1 → 1	b → B	L → L	V → V
2 → 2	C → C	M → M	W → W
3 → 3	d → D	N → N	X → X
4 → 4	E → E	o → O	Y → Y
5 → 5	F → F	P → P	Z → Z
6 → 6	G → G	q → Q	
7 → 7	H → H	r → R	
8 → 8	· → I	S → S	
9 → 9	J → J	t → T	

**FIGURE 2-1. 7-SEGMENT DISPLAY CHARACTERS**

Figure 2-2 shows the front panel of standard units; Figure 2-3 shows the front panel of dual-channel units. Table 2-1 presents the functions of all front panel controls and indicators. Front panel controls listed in Table 2-1 are duplicated for identical (but independent) channels A and B of the dual-channel units, with the exception of the single Power ON/OFF switch which applies to both channels.

**2.2.2 REAR PANEL CONNECTIONS.** Figure 2-4 shows the rear panel of standard single-channel units; figure 2-5 shows the rear panel of dual-channel units. Table 2-2 presents the functions of all rear panel connections. Rear panel connections listed in Table 2-2 are duplicated for identical (but independent) channels A and B of the dual-channel units, with the exception of the single power inlet connector (with two fuses) which apply to both channels.

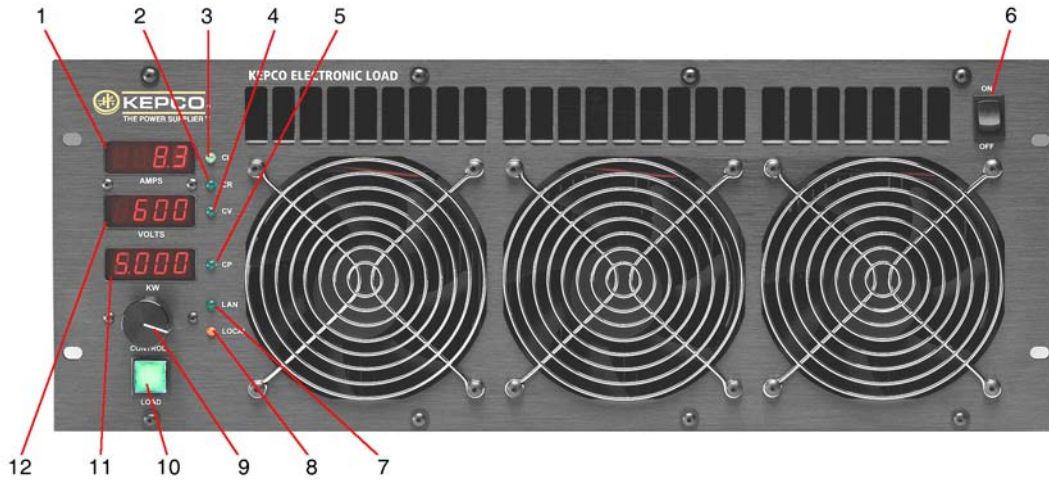

3043466

NOTE: See Table 2-1 for callout descriptions.

FIGURE 2-2. SERIES EL, FRONT PANEL CONTROLS AND INDICATORS

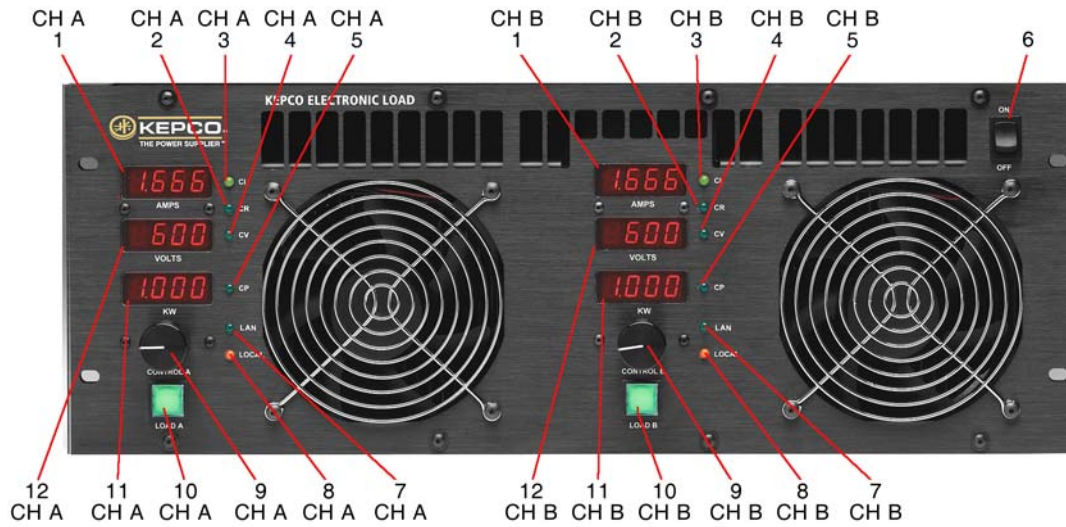

3043465

NOTE: See Table 2-1 for callout descriptions.

FIGURE 2-3. SERIES EL, DUAL MODEL FRONT PANEL CONTROLS AND INDICATORS

TABLE 2-1. FRONT PANEL FUNCTIONS

SEE FIG. 2-2 OR 2-3	COMPONENT	FUNCTION
1	AMPS display	Displays the load test current in Amps (factory default setpoint (see NOTE): 0 Amps) or test current setpoint in Amps. May also show <b>ECUR</b> (ECUR) error message (see PAR. 3.3.1) This fault sets the input to OFF.

**TABLE 2-1. FRONT PANEL FUNCTIONS (CONTINUED)**

SEE FIG. 2-2 OR 2-3	COMPONENT	FUNCTION
CAUTION: Short mode is selected when CR, CI, CV and CP indicators all blink.		
2	CR indicator	On (solid) indicates Constant Resistance Mode; factory default setpoint (see NOTE): 1000 Ohms. On (blinking with other Mode indicators off) indicates Constant Conductance Mode; factory default setpoint: 1mS (0.001 siemens, I/E).
3	CI indicator	On to indicate Constant Current Mode.
4	CV indicator	On to indicate Constant Voltage Mode (factory default setpoint (see NOTE): maximum load voltage).
5	CP indicator	On to indicate Constant Power Mode (factory default setpoint (see NOTE): 0 kilowatts).
6	Power ON/OFF switch	Rocker switch: press top half to turn power on, bottom half to turn power off. NOTE: Cycling power switch from ON to OFF to ON resets fault conditions, but does not reset setpoints (see NOTE).
7	LAN indicator	Green LED on when Ethernet control is active.
8	LOCAL indicator	Red LED on when front panel controls are active.
9	CONTROL rotary encoder/pushbutton switch	When LOCAL is active, Four functions are available as follows: a. <b>Select Mode:</b> Press and hold until Mode indicators and LOAD pushbutton indicator start blinking. Release and rotate knob to select mode indicated by the CI, CR, CV and CP indicators (see Table 3-1). LOAD indicator off while selecting mode. To make a selection either (1) press and hold knob until indicators stop blinking, (2) wait one minute, or (3) press LOAD button to exit selection process. b. <b>Set Value:</b> Rotate knob to adjust the level of the controlled parameter: current, voltage, resistance, conductance or power (see Table 3-1). Rotate clockwise to increase, counterclockwise to decrease. Settings are stored and will be available at next power-up. c. <b>Select Digit:</b> Momentarily press knob to select one digit (blinks). Convenience function allows adjustment at desired resolution. d. <b>Show settings:</b> When Mode is set to OFF, rotating CONTROL while LOAD switch is blinking green and depressed displays Model number, Serial number, IP address, etc. (see PAR. 3.7).
10	LOAD momentary pushbutton switch/indicator	Switch used to alternately enable (load engaged) or disable (load disengaged) the ability of the load to draw current from the UUT. Indicator lights to show load status: <b>Green (steady):</b> Standby - Ready to operate; load does not draw current from the UUT. Parameter displays show voltage, current and power setpoints when CONTROL is momentarily depressed. <b>Green (blinking green on/off):</b> Modes set to off (CR, CI, CV, CP all off), Load can not be engaged. Load configuration information is displayed. <b>Green (blinking green/amber):</b> Input disabled. Input below minimum voltage. Modes set to off while waiting for input to recover (CR, CI, CV, CP all off), Load can not be engaged. Load configuration information is displayed. <b>Amber:</b> Engaged - The load is able to draw current from the UUT, however current may or may not be flowing depending on the setpoint settings. Parameter displays show actual voltage, current and power. <b>Red (blinking):</b> Fault - The load does not draw current from the UUT. The nature of the fault is shown in the appropriate 7-segment display (see PAR.3.3.1) NOTE: The fault condition must be corrected before the load can be engaged; press LOAD switch to change indication to Standby (green) after fault is corrected. <b>Off (not lit):</b> Mode selection using CONTROL is in progress.
11	KW display	Displays the power (Amps x Volts) being dissipated by the load in kilowatts. Also indicates resistance (in Ohms) or conductance (in Siemens) settings. May also show error message <b>EPWR</b> (EPWR) (see PAR. 3.3.1) May also display blinking <b>HOT</b> (HOT) to indicate the unit has started to fold back the output because the internal temperature sensors have detected FET temperature in excess of 130°C. Either fault sets the input to OFF.
12	VOLTS display	Displays test voltage from UUT applied to the load in Volts. May also show error message for over- <b>EVHI</b> (EVHI) or undervoltage <b>EVLO</b> (EVLO) fault (see PAR. 3.3.1). Either fault sets input to OFF.
<p>NOTE:  Factory defaults refer to setpoints for the measurement displayed. These factory default setpoints are designed to ensure that no current is drawn from the UUT when the load is engaged without further adjustment of these parameters. The EL Series load maintains individual setpoints for each mode. These are stored in non-volatile memory, however the factory default setpoints can be restored by issuing *RST command over a remote interface.</p>		

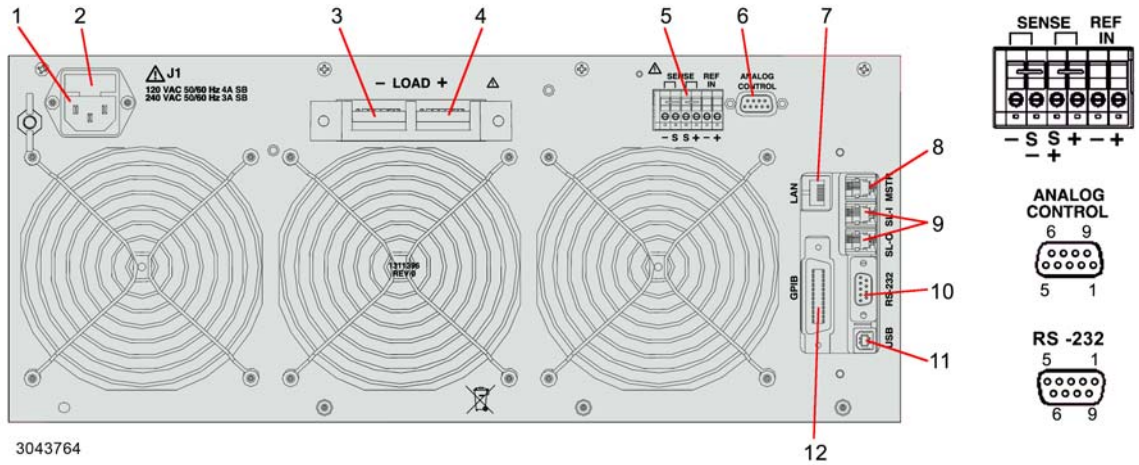

3043764

NOTE: See Table 2-2 for callout descriptions.

FIGURE 2-4. SERIES EL, REAR PANEL TERMINATIONS AND CONNECTORS

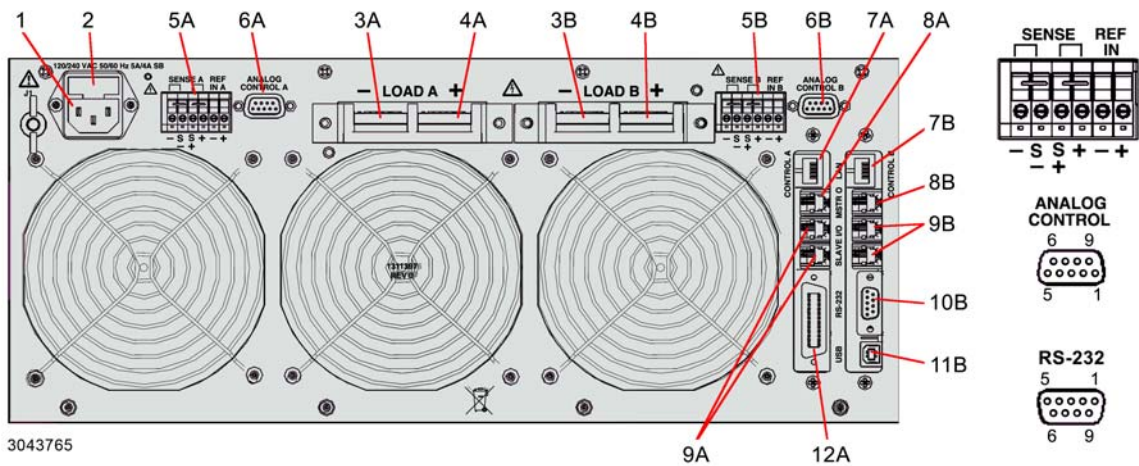

3043765

NOTE: See Table 2-2 for callout descriptions.

FIGURE 2-5. SERIES EL, DUAL OUTPUT MODELS, REAR PANEL TERMINATIONS AND CONNECTORS

**TABLE 2-2. REAR PANEL CONNECTIONS**

FIG. 2-4 or 2-5 INDEX NO.	NAME	DESCRIPTION
1	120VAC 50/60HZ/ 250VAC 50/60HZ/	POWER: IEC 60320-C13 line cord connector to connect mains power (either 120 VAC 50/60 Hz or optional 240V AC 50/60 Hz). NOTE: changing mains power voltage requires internal connector changes (see PAR. 2.3.1).
2	FUSEHOLDER	FUSES (2): <200V a-c: 3.15 Ampere Slo Blow (or 200V a-c or more:2.5 Ampere Slo Blow) (see Table 1-4).
3	LOAD (-) Bus bar	UUT Connections. (-) Negative and (+) Positive: High current connections to UUT. Connections to $\pm$ LOAD are typically made using the supplied 3/8" low-resistance hardware (2 sets: bolt, nut and lockwasher).
4	LOAD (+) Bus bar	
5	SENSE terminals	+S and -S terminals used for remote sensing. Install Jumpers between - and -S and between + and +S for local sensing. Either local or remote sensing must be connected for unit to operate. See 2.6.2.2 for details.
	REF IN terminals	REF IN + and - terminals are used for non-isolated (hazardous) input analog programming (see PAR. 2.6.5.1 for details).
6	ANALOG CONTROL (DB 9 connector)	Analog programming connections. Used for analog programming input/output signals. See PAR 2.6.5 for details. See Table 2-3 for pin assignments.
7	LAN	Optional Ethernet connector.
8	MSTR (MSTR-O on D models) Master Out connector	Standard RS-522 connector. Connects from Master Out to Slave In (SL-I or SL I/O) for multiple units in parallel (see Figure 2-7). See PAR. 2.6.3 for master/slave configurations. See Table 1-5 to order RJ 22 master/slave cable.
9	SL I/O Slave In/Out connector	Standard RS-522 connector. Connects Slave to next slave SL-O to SL-I (SL I/O to SL I/O on D models) if unit is a slave in a parallel configuration using more than two units. Only use Kepco cable (see Table 1-5) for master/slave connections (Figure 2-7).
10	RS-232 connector	RS-232 (three-wire: TXdata, RXdata and ground). Connects with a remote device using RS-232 protocols and SCPI commands. See Table 2-3 for pin assignments.
11	USB connector	Connection to remote device for command, monitoring or calibration. Use USB connector of master to communicate with multiple loads in a master/slave configuration. (see Figure 2-6).
12	GPIB IEEE 488 connector	Optional. When installed, connects user GPIB card with EL load using standard GPIB cable (not supplied).

**TABLE 2-3. ANALOG CONTROL AND RS -232 PORT PIN ASSIGNMENTS**

PIN (1)	ANALOG CONTROL PORT PIN FUNCTION	RS-232 PORT PIN FUNCTION
1	ILOAD output (return pin 6)	N/C - not used
2	Isolated External Input, 0 to 10V (return pin 7)	Received Data (RXD IN)
3	N/C - not used	Transmitted Data (TXD OUT)
4	N/C - not used	N/C - not used
5	N/C - not used	Ground
6	SELV return for ILOAD (pin 1)	N/C - not used
7	SELV return for Isolated External Input (pin 2)	N/C - not used
8	N/C - not used	N/C - not used
9	N/C - not used	N/C - not used

(1) See detail, Figure 2-4 or 2-5 for pin locations.

## 2.3 MAINS POWER REQUIREMENTS

The Electronic Load is delivered configured for operation from 120V a-c  $\pm 10\%$ , 50/60 Hz. The load can be operated from 108V-264 a-c, 50/60 Hz, however when operating at 200V a-c or higher the two fuses must be replaced (see PAR. 2.3.1).

### 2.3.1 CHANGING MAINS POWER VOLTAGE/FUSE REPLACEMENT

To replace the fuses proceed as follows:

1. Disconnect all line voltage sources and UUT sources.
2. Use a screw driver or other tool to pry out the fuseholder (for location, see index #2 of Figure 2-4 for single channel or Figure 2-5 for dual channel).
3. Replace the two fuses as necessary: for operation below 200V a-c refer to Table 1-4 for the fuse part number; for operation above 200V a-c operation refer to Table 1-5.

## 2.4 COOLING

The power devices used within the electronic load are maintained within their operating temperature range by means of internal heat sink assemblies cooled by six cooling fans.

**ALL INLET AND EXHAUST OPENINGS AT THE FRONT AND REAR OF THE ELECTRONIC LOAD MUST BE KEPT CLEAR OF OBSTRUCTION TO ENSURE PROPER AIR ENTRY AND EXHAUST.**

These units are zero-clearance stackable, i.e., no top or side ventilation is required when rack mounting. However, if the unit is rack mounted, or installed within a confined space, care must be taken that the ambient temperature, which is the temperature of the air immediately surrounding the load, does not rise above the specified limits (see Table 1-2).



## 2.5 INSTALLATION



### WARNING!

**The load is very heavy (80 - 90 pounds). Exercise care when lifting, mounting or otherwise handling this product. It is recommended that two or more persons handle the electronic load.**

### 2.5.1 RACK MOUNTING

The unit is intended to be either used on a bench or mounted directly in a 19-inch wide rack. These units are zero-clearance stackable, i.e., no top or side ventilation is required when rack mounting (see cooling, PAR. 2.4). Optional slides (see Table 1-5) can be used. See Figure 2-9 for outline dimensions, see Figure 2-10 for outline dimensions of Dual-channel models.

Four front panel mounting holes are provided. When optional slides are not used, additional support is required.

When at least 1/2U space is available at the bottom, either a bottom support platform (shelf) or side support brackets can be used. Contact factory for proper bracket depending on rail set-back.

For zero-clearance stacking, support must be provided at the rear; contact factory for details.

### 2.5.2 SLIDE MOUNTING



### CAUTION!

**Use of any chassis slide other than CS 06 is unauthorized and may damage the unit and void the warranty.**

Refer to the instructions supplied with Chassis Slide CS 06 for slide installation. Use of screws other than those supplied with CS 06 or pre-installed in slide mounting holes will damage the unit and void the warranty. Contact factory for non-standard mounting options.



### WARNING!

**Do not lean on fully extended load. Weight added to the fully extended unit in excess of 35 lbs. can cause the slide to fail and the unit to fall.**

When replacing a unit with slide mounting, disconnect load cables before pulling the unit out. With the unit fully extended and supported, press release buttons on the two intermediate sections of the slide and remove the unit from the cabinet.

## 2.6 WIRING INSTRUCTIONS

Interconnections between an a-c power source and the load, and between the load and the unit under test are as critical as the interface between other types of electronic equipment. Figure 2-6 illustrates connections for a typical test setup.

Series EL is provided with a three-terminal IEC appliance coupler for connection of the mains supply source, one terminal of which is dedicated for the protective earthing conductor; no other ground or earth connection is required, although the chassis may be separately connected to earth ground for noise or other reasons, such as user or site requirements.

NOTES:

1. Power Supply to Load wiring should be as short as possible and twisted to minimize inductance.
2. Optional, used only for calibration and/or precise data acquisition.
3. Computer (either RS 232 or USB) connections not required if local control is used.
4. Local sensing shown. For remote sensing, remove jumpers between - and -S and between + and +S. Use twisted pair to connect -S to negative terminal, +S to positive terminal of test source.
5. Optional, used to convert 0 to 10V analog voltage output to load current.

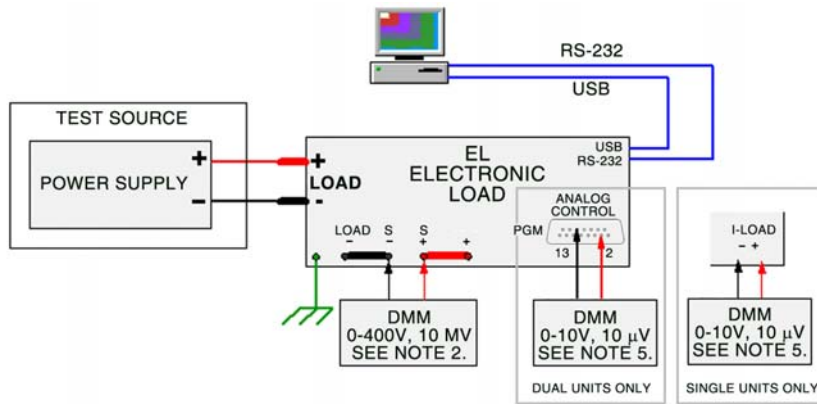

3043472

FIGURE 2-6. TYPICAL INTERCONNECTIONS

### 2.6.1 MAINS POWER

Mains power is connected at the rear panel of the Series EL Electronic Load (see Figure 2-4) via the IEC 320-style recessed power inlet connector with integral fuse holder (see PAR. 2.3 for mains power requirements).

It is recommended that the 1/4-inch bolt with wingnut and flat washers (supplied) at the top left of the rear panel be connected to earth ground.

### 2.6.2 UNIT UNDER TEST (UUT) TO LOAD CONNECTION



## WARNING!

Loose test connections between the UUT and the Series EL load can lead to load instability, erratic operation and possible equipment damage. In addition, loose connections or insufficiently sized conductors can become very hot and cause burns.



## CAUTION!

Never open the connection between the Series EL load and UUT while the load is enabled and current is flowing. Always disable Series EL load and/or UUT power source output first. Arcing may damage either the UUT or the EL Series load.

#### 2.6.2.1 POWER CONNECTIONS

Connections between the UUT and the Series EL Electronic Load are achieved via the (+) and (-) LOAD terminals located on the rear panel.

The load is capable of drawing very high currents. Connections between the UUT and the load should be of suitably large wire, sized to carry the maximum current. It is extremely important to ensure all connections are tight and corrosion free. Regular inspection of these connections is important. Inspection interval should be established based on frequency and type of use. Once per week is recommended, however where cable movement or vibration is likely, more frequent inspections are warranted.

Use two wrenches to tighten the 3/8 in. (5/16 in. for dual output models) Bolt/Nut on the bus bars. these hardware items are brass and could shear if overtightened: recommended maximum torque is 20 lb-ft for the 3/8 in. hardware, 10 lb-ft for the 5/16 in. hardware used on dual output models. The small resistance created by a loose joint can cause very destructive heating (e.g., a 1 milliohm joint with a current of 400 Amperes generates 160 watts).



## WARNING

**Reversing the polarity at the LOAD terminals will cause immediate and significant damage to the load and UUT!**

### 2.6.2.2 SENSE CONNECTIONS

Remote Sensing terminals ( $\pm S$ ) are provided for connection to the UUT in order to compensate for voltage drops on the power cables connected to the  $\pm$ LOAD terminals. When remote sensing is used, the readings shown on the front panel accurately reflect the output of the UUT.

To use remote sensing first remove the local sense jumpers (NOTE: Local sense jumpers can be fabricated as needed using #18 AWG stranded wire) installed on the SENSE Terminal block. Then connect wires (#24 AWG or 22 AWG) from +S to the positive output of the UUT, and from -S to the negative output of the UUT. Twisting of sense wires is recommended.

If remote sensing is not used, the pre-installed local sensing jumpers between S+ and + and between S- and - must remain in place as shown in Figure 2-4 (single) or 2-5 (dual). Operating the unit with neither local nor remote sensing in place will result in erroneous readings.

**CAUTION: When connecting the load to the UUT be very careful not to accidentally short the UUT output in the process of connecting the wiring. Best practice is to make the connection to the UUT Positive (+) output connector the last connection.**

For remote sensing, remove jumpers from  $\pm S$  and connect  $\pm S$  terminals to corresponding  $\pm$  output terminals at the unit under test.

Connect the Series EL Electronic Load to the UUT using cabling appropriate for the current and voltage drawn during testing. Contact Kepco if assistance is needed in selecting the appropriate wire size, length and physical configuration. Ensure all connectors are suitable for the currents and that connections are tight. Connections should be re-checked on a regular basis (see PAR. 2.6) to ensure continued low-resistance connections.

### 2.6.2.3 GROUNDING

It is required for EN 61326-1 compliance that the 1/4-inch bolt with wingnut and flat washers (supplied) at the top left of the rear panel be connected to earth ground.

The LOAD Bus bars are isolated from the chassis and from the control circuits well into the 100s of volts. The resistance between the REF IN - terminal and the load's negative connection is over 300 K ohms and the REF IN pins are rated for 600 volts. Since a single point failure could render this resistance 0 ohms, it is designated as Hazardous. The SELV analog control input (ANALOG CONTROL connector pin 4, pin 8 return) is referenced to the chassis via a small 100 ohm resistor and as a result there is no possibility of equipment damage.

The I-Load output (ANALOG CONTROL connector, pin 5, pin 9 SELV return) is independently isolated from the control circuits and therefore is double-isolated from all other external connections. Lastly, all of the Remote Interface inputs (RS-232, USB 2.0, RS-522), optional LAN and GPIB) are optically isolated from the control circuits and are therefore doubly isolated from all other circuits.

### 2.6.3 PARALLEL MASTER/SLAVE CONFIGURATIONS

Up to 15 Series EL Electronic Loads may be paralleled for additional current and/or power handling capability. All units must have the same voltage rating. One load is designated as the Master, and the rest are designated as slaves. Master/slave communications are via proprietary protocols using special cable(s) connected to the MSTR O (Master Out) and SLAVE I/O connectors on the rear panel (see Table 1-5). Connections are from MSTR O to SLAVE I/O, then for subsequent slaves, from SLAVE I/O to SLAVE I/O of the next unit. Computer/load communications are via either the RS-232 or USB (or optional LAN or GPIB) interfaces, and are applied to the master only. Figure 2-7 illustrates connections for a typical master/slave system.

In a Master-Slave configuration, two or more Loads operate in parallel to increase the total current and power capacity.

**CAUTION: Loads in Master-Slave configuration are always operated in PARALLEL, never in series. Each Load in the system must have exactly the same maximum voltage limit-otherwise the Load internal software will not allow the Loads to configure as a Master-Slave system. Paralleling two Loads of unequal voltage rating and applying a voltage greater than the limits of the Load with the lower voltage rating can result in the destruction of the Load, the connected source or both.**

Typically Loads are stacked vertically to minimize the distance between the  $\pm$  LOAD terminals. It is essential to keep this cabling as short as possible due to the high currents flowing during operation. One of the Loads is designated as the Master and the other as the Slave. Any Load may be designated as the Master.

Master-Slave configuration is achieved by two interconnections at the Load rear panel (see Figure 2-7): First connect the  $\pm$  LOAD terminals of master and all slaves in parallel using sufficiently heavy cable to carry the maximum current expected to be drawn by any of the individual loads. Next connect the UUT (Unit Under Test) to the  $\pm$  LOAD terminals. Use of No. 6 (or larger) Welding Cable is recommended for flexibility, current carrying capacity and insulation.

For remote operation use the supplied RJ-22 Master-Slave communications bus cables (these use miniature modular connectors - do not try to use conventional modular telephone cables). Connect an RJ-22 bus cable from the MSTR O (Master Out) which is the upper most RJ-22 Jack, to the upper SLAVE I/O RJ-22 Jack on the slave. For more than one slave, connect lower SLAVE I/O jack to the next unit's upper SLAVE I/O jack, and so on. No terminations are needed at the final slave in the daisy chain.

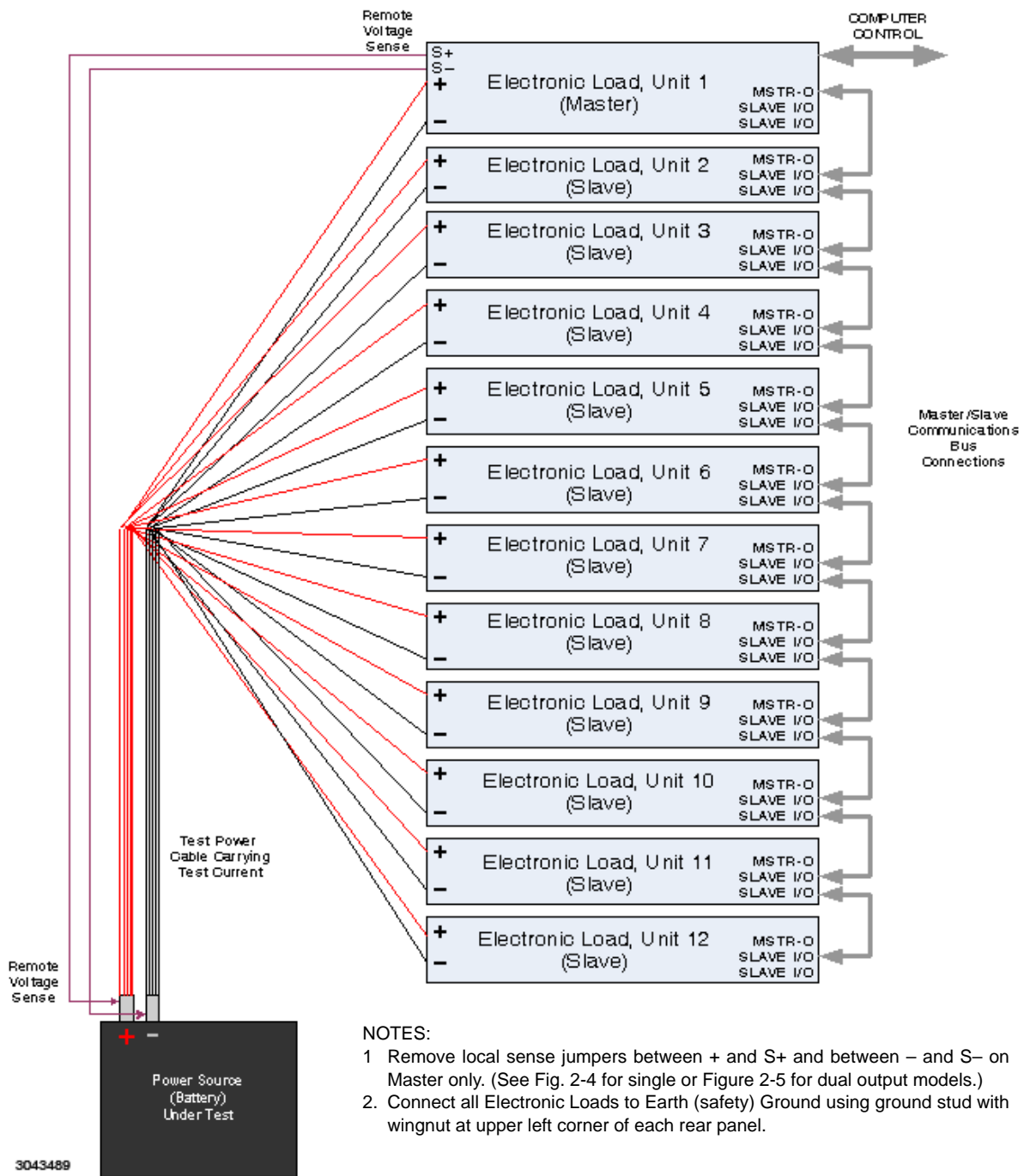

FIGURE 2-7. TYPICAL MASTER/SLAVE INTERCONNECTIONS

## 2.6.4 PROTECTIVE COVER INSTALLATION

After wiring is complete, it is advisable to install the protective cover over the output load terminals to guard against accidental contact with live terminals. The cover and SEM mounting screws are supplied with 200V, 400V and 600V models and are optional accessories for 50V models (see Table 1-4 for part numbers and screw quantities). The cover is comprised of two pieces, a metal cover protecting the bottom and sides, and a clear plastic piece that protects the front and top.

First mount the metal cover to the chassis using two SEM screws. Install the clear Lexan cover over the top of the metal cover and secure to the metal cover using two SEM screws (three screws for dual chassis models).

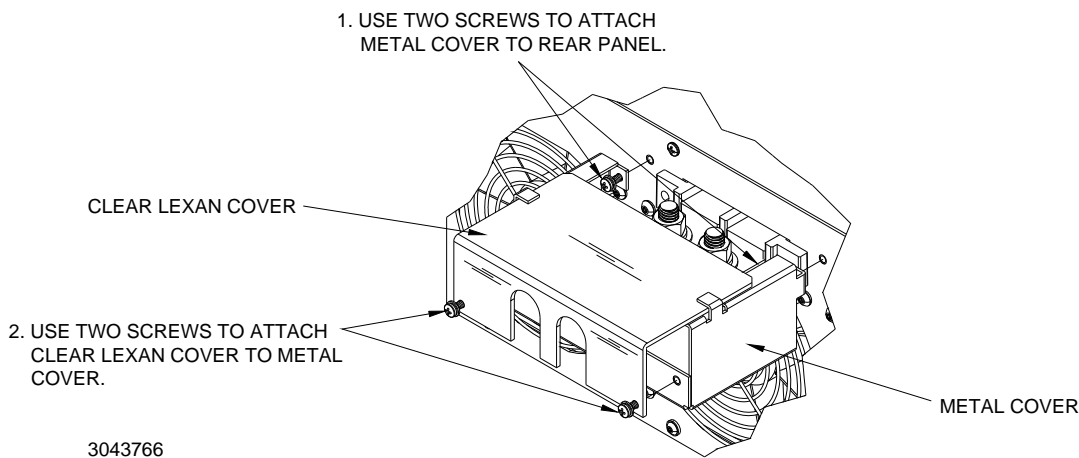

FIGURE 2-8. PROTECTIVE COVER INSTALLATION, SINGLE OUTPUT MODEL (TYPICAL)

## 2.6.5 ANALOG CONTROL CONNECTIONS

Either of two separate inputs can be used for remote analog programming of the load. Each input can adjust the controlled parameter from 0 to full scale using a 0 to 10V external signal. Refer to PAR. B.96 to disable analog control, or to enable one of the two external inputs: non-isolated, (factory default: enabled, see PAR. 2.6.5.1) or isolated (see PAR. 2.6.5.2). Either analog input can be summed with the digital input, allowing e.g., an analog waveform to ride on the level established by the digital setpoint; see PAR. 3.17 for analog programming details. For Master/Slave configurations, the remote analog signal must be applied to all parallel-connected units.

**CAUTION: The non-isolated input is deemed hazardous per CE and UL requirements because a single point failure could cause a short between REF IN – and the LOAD – terminal of the unit, leading to possible lethal and equipment-damaging voltage at the REF IN – terminal. When the non-isolated input is disabled, the input pins are not mechanically disconnected.**

### 2.6.5.1 NON-ISOLATED (HAZARDOUS) EXTERNAL INPUT (FAST)

The 0 to 10V signal applied to REF IN + terminal (REF IN – return) at the rear panel adjusts the controlled parameter (depending on mode selection) from 0 to full scale. (For  $\pm$ REF IN location see Figure 2-4 for single or Figure 2-5 for dual output models.) This input uses a 300K Ohm buffer that is not galvanically isolated; the direct connection between REF IN+ and the input means the response time is fast: 20 microsecond transients can be accommodated with rise/fall times

of under 5 microseconds. This feature may be used to prevent transients that can occur at the load when going from off to on. Refer to PAR. B.96 to enable or disable this input.

#### **2.6.5.2 ISOLATED EXTERNAL INPUT (SELV)**

The 0 to 10V input at pin 2 (pin 7 SELV return) of the ANALOG CONTROL connector (see Figure 2-4 for single or Figure 2-5 for dual output models) adjusts the controlled parameter (depending on mode selection) from 0 to full scale. (NOTE: This signal is not provided on Model EL 3K-25-400DG). This input is referenced to the chassis via a 100 Ohm resistance, resulting in no possibility of lethal or equipment damaging voltage on the input pins. This SELV input goes from A/D to D/A conversion leading to slower response than the non-isolated input: 60 microsecond transients can be accommodated rise/fall times of 20-30 microseconds. Refer to PAR. B.96 to enable or disable this input.

#### **2.6.6 CURRENT MONITOR CONNECTIONS**

The output signal (ILOAD) at pin 1 (pin 6 SELV return) of the ANALOG CONTROL connector (see Figure 2-4 for single or Figure 2-5 for dual output models) is 0 to 10V, corresponding to 0 to full scale of the load's rated current. Monitor current using an external voltmeter connected across pin 1 and pin 6 when the load is drawing current from the UUT. For Master/Slave configurations, each ILOAD output reflects the current flowing in that individual load.

### **2.7 DIGITAL CONNECTIONS**

When communicating with the Series EL via a computer interface, the Series EL responds to IEEE 488.2 and SCPI (Standard Commands for Programmable Instruments) commands and queries. Compatible IEEE 488.2 commands and queries are listed in Appendix A. The complete list of SCPI commands designed for the Series EL Electronic Load are listed in Appendix B.

#### **2.7.1 STANDARD UNITS**

If control via the USB or RS-232 computer interface is desired, the computer should be connected to the load via either the USB 2.0 type B connector or the RS-232 interface connector located at the rear panel.

For simple communications a terminal emulator program such as HyperTerminal provides the necessary interface. No drivers are required when using the RS-232 interface, however if USB communications are used, a special driver must be installed (the USB interface is not *plug and play*). Refer to the Kepeco website to download the Series EL USB Driver Installation Manual that describes how to download and install the driver, as well as how to establish communications between the Series EL load and the computer using a terminal emulator:

[www.kepecopower.com/support/opmanls.com#e](http://www.kepecopower.com/support/opmanls.com#e)

NOTE: If using USB and HyperTerminal, it is advisable to first turn on the Series EL load and then launch HyperTerminal as HyperTerminal may become dysfunctional (hung up) if power is removed from the USB connection before HyperTerminal is closed or before the connection is closed.

#### **2.7.2 G OPTION - GPIB INTERFACE**

For G option units, connect the EL Load GPIB connector at the rear panel to the GPIB bus using a standard GPIB cable (not supplied). NOTE: GPIB drivers are not available.

#### **2.7.3 E OPTION - ETHERNET INTERFACE**

For E option units, connect a computer to the LAN connector at the rear panel using a standard RJ 45 Ethernet cable (not supplied). The LAN interface uses a socket connection at Port 5025.

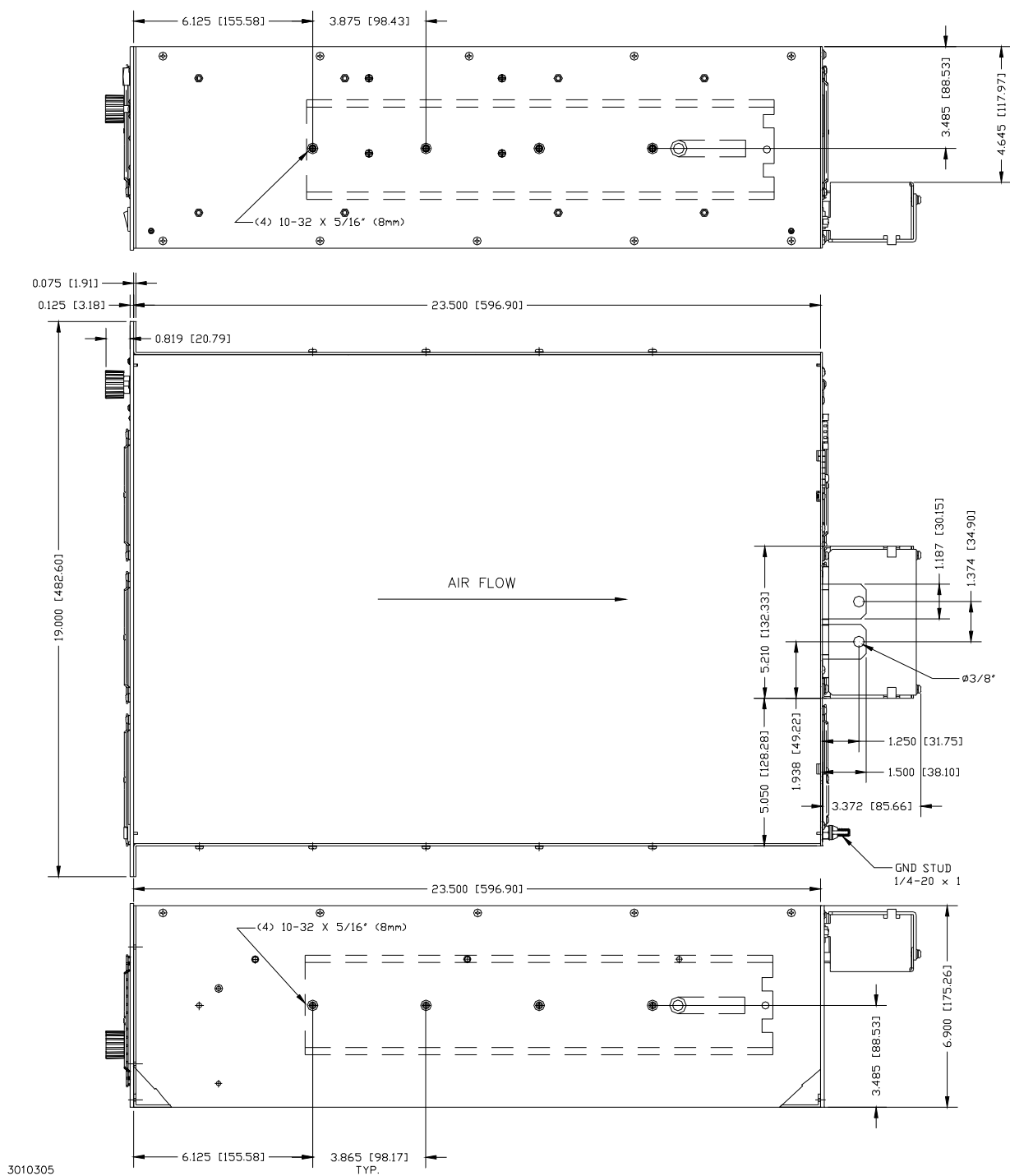
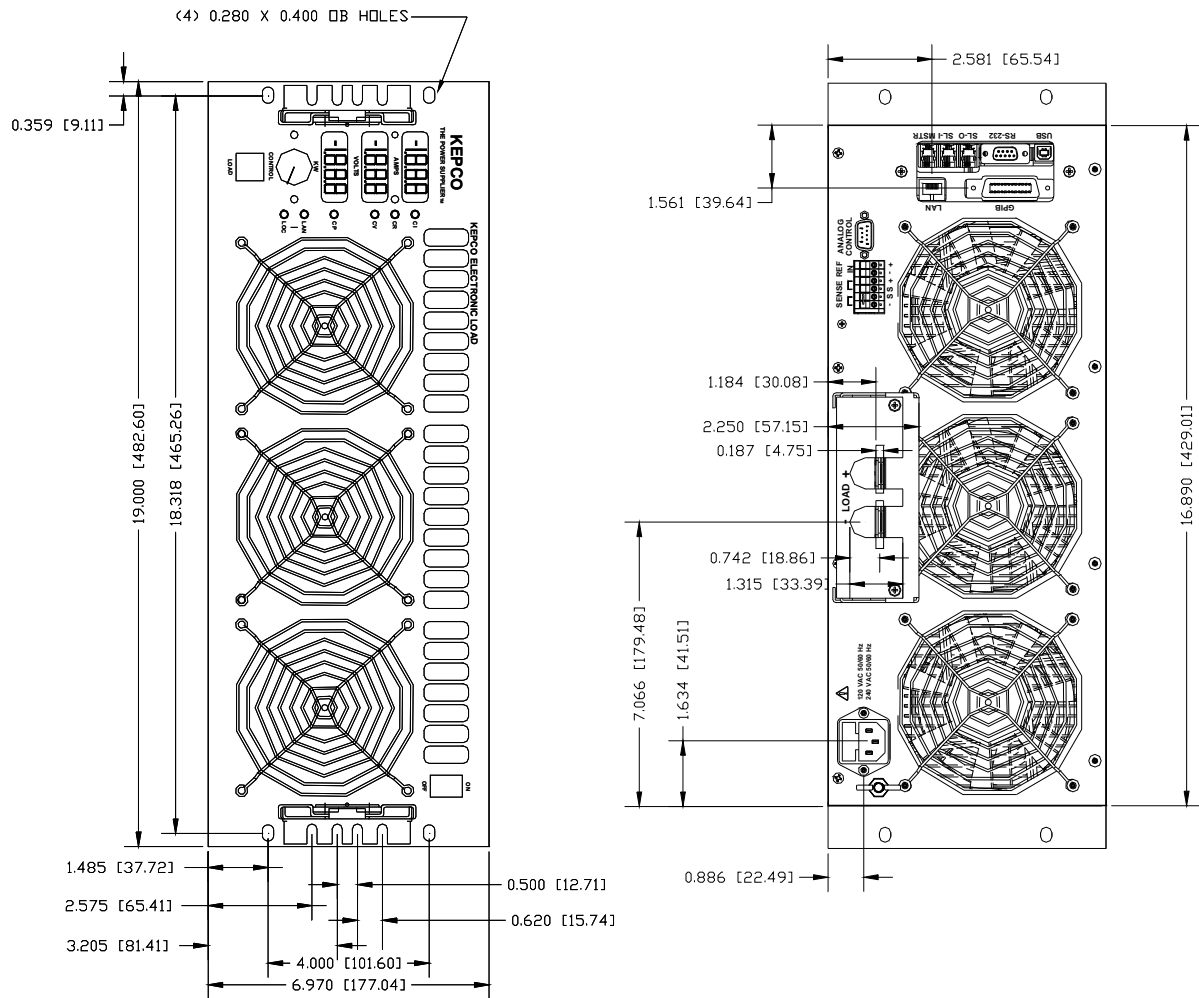

FIGURE 2-9. EL LOAD, OUTLINE DIMENSION DRAWING (SHEET 1 OF 2)





NOTES:

- MATERIAL: A) CHASSIS & COVER: 0.075" MILD STEEL.  
B) FRONT PANEL: 0.125" THICK 6061-T6 ALUMINUM.  
C) REAR PANEL: 0.064" THICK 16 GA. CRS.
- FINISH: A) CHASSIS & COVER: BLACK CRINKLE PAINT.  
B) FRONT & REAR PANELS: BLACK POWDERCOAT.
- DIMENSIONS IN PARENTHESES ARE IN MILLIMETERS.
- TOLERANCES: A. BETWEEN MOUNTING HOLES:  $\pm 1/64$  (0.4)  
B. ALL OTHER DIMENSIONS  $\pm 1/32$  (0.8), EXCEPT AS NOTED.

3010305

FIGURE 2-9. EL LOAD, OUTLINE DIMENSION DRAWING (SHEET 2 OF 2)

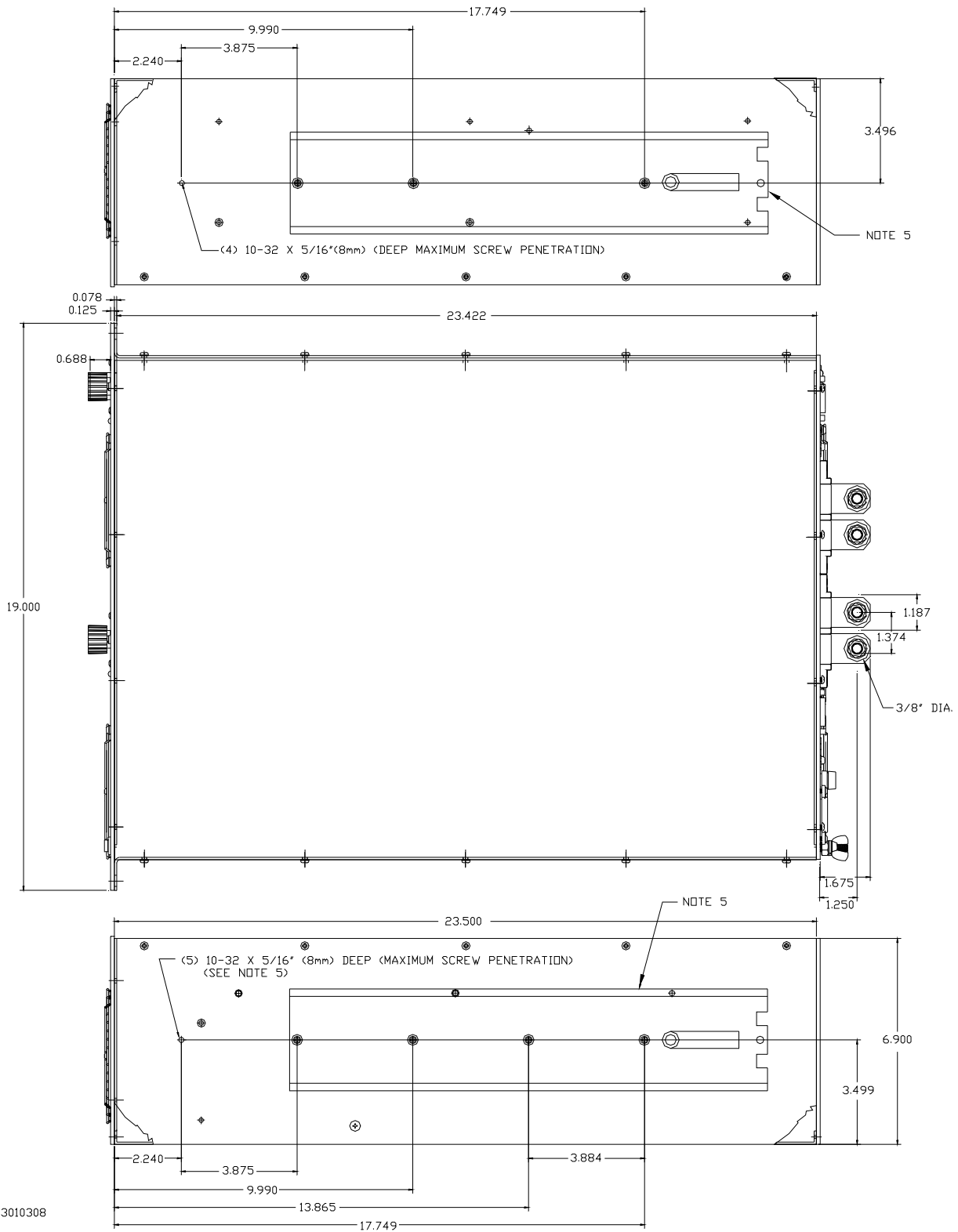
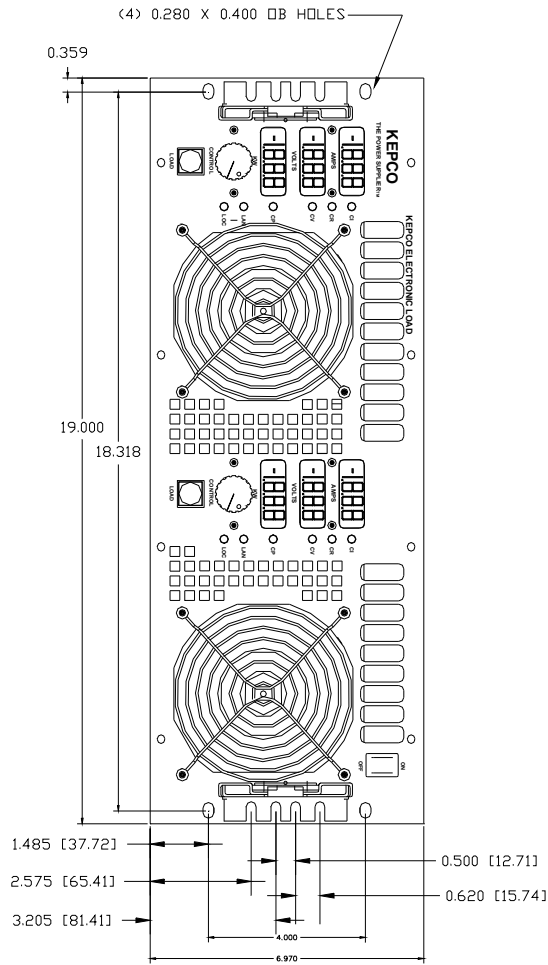
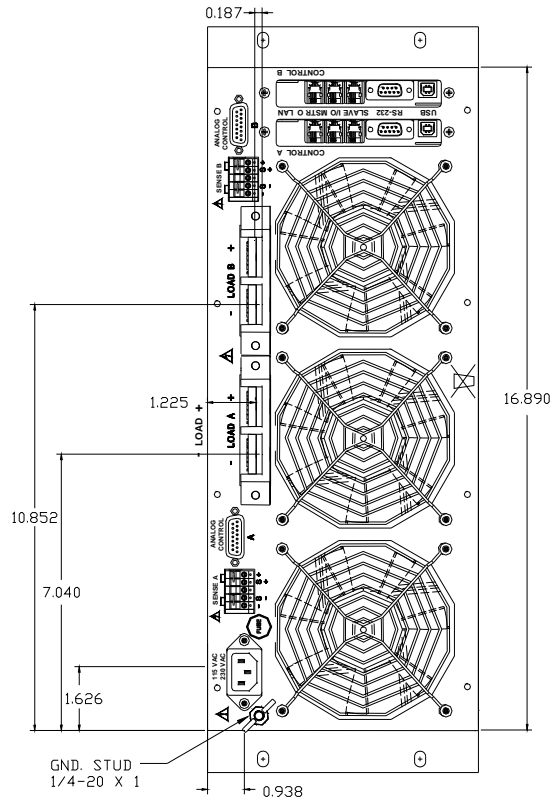

FIGURE 2-10. EL LOAD, DUAL-CHANNEL, OUTLINE DIMENSION DRAWING (SHEET 1 OF 2)



3010308



NOTES:

1. MATERIAL: A) CHASSIS & COVER: 0.075" MILD STEEL.  
B) FRONT PANEL: 0.125" THICK 6061-T6 ALUMINUM.  
C) REAR PANEL: 0.064" THICK 16 GA. CRS.
2. FINISH: A) CHASSIS & COVER: BLACK CRINKLE PAINT.  
B) FRONT & REAR PANELS: BLACK POWDERCOAT.
3. DIMENSIONS IN PARENTHESES ARE IN MILLIMETERS.
4. TOLERANCES: A. BETWEEN MOUNTING HOLES:  $\pm 1/64$  (0.4)  
B. ALL OTHER DIMENSIONS  $\pm 1/32$  (0.8), EXCEPT AS NOTED.
5. ONLY KEPCO CHASSIS SLIDES, MODEL CS06, ARE AUTHORIZED. USE OF ANY OTHER SLIDES, OR MOUNTING SCREWS EXCEEDING THE LENGTH SPECIFIED, CAN DAMAGE UNIT AND WILL VOID THE WARRANTY. OBSERVE CAUTIONS AND WARNINGS SPECIFIED IN CS06 INSTRUCTION SHEET AND EL OPERATOR MANUAL.

FIGURE 2-10. EL LOAD, DUAL-CHANNEL, OUTLINE DIMENSION DRAWING (SHEET 2 OF 2)



## SECTION 3 - OPERATION

### 3.1 GENERAL

This section contains general operating instructions for the Series EL Electronic Load. Refer to Section 2 for a description of the controls, display and terminals. When loading sources of electrical energy be sure to use appropriate precautions where high-currents and potentially high voltages may be present.



### WARNING

**An electronic load can present an extremely low resistance to a source of electrical energy. In some cases this may be the equivalent of placing a short circuit at the source output. This may have disastrous consequences if done unintentionally.**

**Be sure the load parameter settings are appropriate for the source being tested.**



### CAUTION!

**Never power down the Series EL load while the load is enabled and current is flowing. Always disable Series EL load and/or UUT power source first. Otherwise damage to the EL Series load is likely to occur.**

### 3.2 FACTORY DEFAULT SETTINGS

The unit is shipped with the following settings preset at the factory:

- Current set point                    0 A
- Voltage set point                    Load maximum voltage
- Power set point                      0 kWatts
- Overvoltage limit                    5% above rated maximum
- Undervoltage limit                   0V (deactivated)
- Overcurrent limit                    5% above rated maximum
- Overpower limit                      5% above rated maximum
- Resistance set point                1,000 ohms
- Conductance set point               1 mS (0.001 siemens)
- System damping                      5
- Mode damping                        3
- Local control                         Fully enabled
- Load ON/OFF                        OFF
- SYST:COMM:ECHO                    OFF
- Input on/off:
  - Voltage cutoff level:               10 Volts (4 Volts for 50V models)
  - Cutoff time:                         10 Seconds
  - Ramp                                  100 milliseconds
- External Input:                       Non-isolated (hazardous) input enabled

### 3.3 TURNING THE UNIT ON

1. Connect the load to the UUT (Unit Under Test) (see PAR. 2.6.2)
2. Connect the load to mains power (see PAR. 2.6.1)
3. Connect the load to a computer system
4. Press the front panel Power ON/OFF switch to ON. All fans turn on, then turn off after 10 seconds except for the right rear fan. The unit performs power-up testing which should take about 30 seconds to complete. If power-up testing is successful, the LOAD switch lights green (steady). If it is illuminated Red, a Fault condition exists that must be corrected prior to using the load (see PAR. 3.3.1).
5. Ensure the computer control system is turned on and communication with the Series EL Electronic Load is established. Current status of the Series EL Electronic Load modules is shown by front panel displays.
6. When the unit is first turned on, the LOAD setting and remote computer commands (INPUT/OUTPUT) are initialized for zero current draw. Setpoints, mode, limits, and other settings remain from prior work. The load is shipped in CI mode and set for 0 Amperes.
7. When first initiating a load, it is advisable to make a "Test run" at a nominal load level (e.g., 10% of the expected parameter setting). This allows the user to ensure all connections are properly made and results are as expected when engaging the load.

#### 3.3.1 ERROR CONDITIONS

- **EVHI** (EVHI) appearing in the VOLTS display indicates the established voltage limits were exceeded at the remote sense point.
- **EVLO** (EVLO) appearing in the VOLTS display indicates the UUT voltage (at the remote sense point) dropped below the internally set low voltage limit.
- **ECUR** (ECUR):appearing in the CURR display indicates the UUT current has exceeded the current protect setting. The default current protect setting is 105% of rated current.
- **EPWR** (EPWR) appearing in the PWR display indicates the UUT power has exceeded the power protection point. The default power protection setting is 101% of rated power.
- **EHOT** (EHOT) appearing in the PWR display indicates that the temperature of one or more of the power dissipating Power MOSFETs exceeded safe operating limits. (Note: this may cause either a reduction of the load maximum current/power handling ability or a complete inability to use the load depending on the degree of overheating.)

### 3.4 SELECTING THE MODE AND SETPOINT

To select a mode and setpoint for the controlled parameter (current, power, voltage, resistance or conductance) prior to drawing current from the UUT, verify that the LOAD pushbutton indicator is green (steady) and proceed as follows:

1. Depress and hold the CONTROL knob for 3 seconds. The LOAD pushbutton indicator goes from green to off. Release the CONTROL knob. Rotating the CONTROL knob sequentially selects the operating mode in the order: CV, CI, CP, CR, CS, SHORT and OFF (see Table 3-1). To set the selected mode, press and hold CONTROL knob for 3 seconds; LOAD pushbutton indicator goes from off to green.
2. After the operating mode is selected, set the CONTROL resolution by momentarily depressing the CONTROL knob (CONTROL knob must be depressed twice the first time it is used after a mode selection). This causes one digit in the selected mode parameter display (AMPS, VOLTS, KW) to blink while showing the setpoint. The blinking digit indicates the CONTROL resolution setting for one click of rotation. Momentarily depressing the CONTROL knob again shifts the resolution selection to the next digit.
3. Rotate the CONTROL (clockwise to increase or counterclockwise to decrease) to adjust the parameter setpoint. Once the setpoint is selected, the setpoint remains displayed momentarily and then the display returns to displaying the measured parameter value.

**TABLE 3-1. MODE SELECTION AND ADJUSTMENTS**

MODE INDICATOR	MODE SELECTED	ADJUSTMENT
Only CI on (solid)	CI mode (Constant Current).	CONTROL sets constant current level in Amperes as viewed on AMPS display.
Only CR on (solid)	CR mode (Resistance)	CONTROL sets resistance in Ohms as viewed on KW display.
Only CR on (blinking)	CS mode (Conductance)	CONTROL sets conductance in Siemens (= I in Amps / E in Volts) as viewed on KW display.
Only CV on (solid)	CV mode (Voltage)	CONTROL sets voltage in Volts as viewed on VOLTS display.
Only CP on (solid)	CP mode (Constant Power)	CONTROL sets constant power level in kilowatts as viewed on KW display.
CI, CR, CV and CP all blinking	Short mode (lowest ON resistance possible).	Short mode; maximum current, no adjustment. <b>USE CAUTION before selecting this mode.</b>
CI, CR, CV and CP all off	Off	Modes off, no adjustment. Load will not engage, no setpoints are active and load will not conduct current. When modes are off, pressing LOAD switch causes LOAD indicator to blink green, then rotate CONTROL to show model and serial number. on front panel displays (see PAR. 3.7).

### 3.5 ENGAGING THE LOAD

1. After selecting the mode and setpoint (PAR 3.4), momentarily press the LOAD pushbutton to engage the UUT, causing the load to draw current from the UUT at the level determined by the setpoint. LOAD pushbutton illumination changes to amber and the front panel displays show the measured parameters: voltage, current and power.
2. Rotating CONTROL with the load engaged (LOAD indicator amber) causes the controlled parameter to increase (clockwise) or decrease (counterclockwise) in steps at the resolution selected in PAR 3.4, step 2 above. The VOLTS, AMPS and KW displays show the measured parameters any time the load is engaged (LOAD indicator amber).

### 3.6 DISENGAGING THE LOAD

With the load engaged (LOAD indicator amber), disengage the load from the UUT by momentarily depressing the LOAD pushbutton (illumination changes to steady green) causing the load to stop drawing current from the UUT.

### 3.7 VIEWING CONFIGURATION INFORMATION

When the Mode is OFF (none of the mode LEDs are illuminated), momentarily depressing the LOAD pushbutton (illumination changes to blinking green) allows configuration information to be viewed. Rotating CONTROL clockwise sequences the VOLTS, AMPS and KW displays as follows (counterclockwise sequences in reverse order starting with Firmware Version):

- Model Information (displayed as AMPS, VOLTS and KW in respective display).
- Serial Number **5700** (SN) in AMPS display, serial no. in VOLTS and KW displays)
- IP Mode **SRCE** (SRCE) in VOLTS display, **USER** (USER) (static) or **DHCP** (DHCP) in AMPS display). Refer to PAR. B.86 for description of IP Modes. To change IP Mode from the front panel see PAR. 3.8.
- IP Address (1st octet = left 3 digits of AMPS, 2nd octet = right digit of AMPS, left 2 digits of VOLTS, 3rd octet = right 2 digits of VOLTS, left digit of KW, 4th octet = right 3 digits of KW display.) To change the static IP address from the front panel, see PAR. 3.9. IP Address is 0.0.0.0 if ethernet option is not installed.
- Subnet Mask (same as IP address). To change the Subnet Mask from the front panel, see PAR. 3.9.
- Mac Address. Displays the hex Mac address if the ethernet option is installed. Mac Address is 0.0.0.0 and CR indicator blinks if ethernet option is not installed. Mac Address can NOT be changed by the user.
- GPIB address **0P16** (GPIB) in AMPS, **ADDR** (ADDR) in VOLTS and GPIB address in KW display). To change the GPIB address from the front panel, see PAR. 3.10. GPIB address is 33 if GPIB option is not installed.
- Firmware Version **8E20** (VER) in AMPS display, Firmware Version in VOLTS display, Suffix in KW display).
- back to Model.

To exit, momentarily depress LOAD pushbutton to restore OFF mode (none of the mode LEDs are illuminated and the LOAD pushbutton illumination is steady green).



### 3.8 CHANGING IP MODE

When the Mode is OFF (none of the mode LEDs are illuminated), momentarily depressing the LOAD pushbutton (illumination changes to blinking green) allows configuration information to be viewed.

NOTE: To abort process without changing the IP Mode, momentarily depress LOAD pushbutton to restore OFF mode (none of the mode LEDs are illuminated and the LOAD pushbutton illumination is steady green).

1. Rotate CONTROL until AMPS display shows **IP00** (IP), VOLTS shows **SRCE** (SRCE) and KW shows IP Mode currently selected, either **USER** (USER) (static) or **DHCP** (DHCP)
2. Momentarily depress CONTROL: the mode shown in KW display blinks.
3. Rotate CONTROL to change IP Mode: **USER** (USER) (static) or **DHCP** (DHCP), then momentarily depress CONTROL to return to OFF mode (none of the mode LEDs are illuminated and the LOAD pushbutton illumination is steady green).

### 3.9 CHANGING STATIC IP ADDRESS OR SUBNET MASK

When the Mode is OFF (none of the mode LEDs are illuminated), momentarily depressing the LOAD pushbutton (illumination changes to blinking green) allows configuration information to be viewed.

NOTE: To abort process without changing the address or mask, momentarily depress LOAD pushbutton to restore OFF mode (none of the mode LEDs are illuminated and the LOAD pushbutton illumination is steady green).

1. Rotate CONTROL until AMPS, VOLTS and KW show 12 digits (4 groups of 3, referred to as octets) of IP address or Subnet Mask.
2. Momentarily depress CONTROL; the right three digits of KW display blink (this is the 4th octet, the right-most three digits of the address). Rotate CONTROL to change digits in KW display, then momentarily depress CONTROL.
3. The 3rd octet (right two digits of VOLTS display and left digit of KW display) now blinks. Rotate CONTROL to change digits, then momentarily depress CONTROL.
4. The 2nd octet (right digit of AMPS display and left two digits of VOLTS display) now blinks. Rotate CONTROL to change digits, then momentarily depress CONTROL.
5. The 1st octet (left three digits of AMPS display) now blinks. Rotate CONTROL to change digits, then momentarily depress CONTROL to return to OFF mode (none of the mode LEDs are illuminated and the LOAD pushbutton illumination is steady green).

### 3.10 CHANGING GPIB ADDRESS

When the Mode is OFF (none of the mode LEDs are illuminated), momentarily depressing the LOAD pushbutton (illumination changes to blinking green) allows configuration information to be viewed.

NOTE: To abort process without changing the GPIB address, momentarily depress LOAD pushbutton to restore OFF mode (none of the mode LEDs are illuminated and the LOAD pushbutton illumination is steady green).

1. Rotate CONTROL until AMPS display shows **GPBB** (GPIB), VOLTS shows **ADDR** (ADDR) and KW shows value of GPIB address.
2. Momentarily depress CONTROL: the address in KW display blinks.
3. Rotate CONTROL to change GPIB address, then momentarily depress CONTROL to return to OFF mode (none of the mode LEDs are illuminated and the LOAD pushbutton illumination is steady green).

### 3.11 OPERATION OF MASTER/SLAVE CONFIGURATIONS.

Up to 15 Series EL Electronic Loads may be paralleled for additional current handling capability. All units must have the same voltage rating. One load is designated as the Master, and the rest are designated as slaves. Refer to PAR. 2.6.3 for connections.

A Master/Slave combination responds to an \*IDN? query with the \*IDN string from first the Master and then the Slave(s).

#### 3.11.1 POWER UP

Turn on power to all loads connected as Master/Slave. The units will go through power-up and reset cycles until all slaves are recognized (this may take a few minutes). NOTE: Power-up time can be reduced by powering up the slaves 10 to 20 seconds before powering up the master.

- The LOAD button on each Slave Load turns green once the Load completes its diagnostic tests.
- The VOLTS display on the Slave(s) reads **SLAV** (SLAV) (Slave).
- The LOAD button on the Master Load turns green once the Master Load 1) completes its diagnostic routine, 2) interrogates the Slave(s) for Master-Slave connection eligibility and ratings, 3) establishes the overall Master-Slave Load configuration.

#### 3.11.2 LOCAL (FRONT PANEL) OPERATION

The Load can be operated from the Master front panel as described in the previous paragraphs for a single unit. Only the Master Load front panel is active.

#### 3.11.3 REMOTE (COMPUTER) OPERATION

If a computer is connected to the Master Load of a master/slave configuration in terminal display mode, the information shown in Figure 3-2 is displayed at startup (boot). The Master-Slave configuration responds to the SCPI command set described in Appendix A and B.

### 3.11.4 INDICATIONS DURING MASTER/SLAVE OPERATION

The Master Load displays:

- AMPS: Total Current drawn by the Master/Slave configuration
- VOLTS: Voltage applied to each of the Loads
- KW: Total power in kW drawn by the Master/Slave configuration

Slave Load(s) display:

- AMPS: Current drawn by the individual Slave
- VOLTS: reads **SLAV** (SLAV) showing unit is a slave connected to Master.
- KW: Power in kW drawn by the individual Slave.

### 3.11.5 MASTER/SLAVE CONTROLS AND INDICATORS

Controls and indicators function as described for a single unit, however controls are only active on the Master Load. Indicators on the Master Load are for Master/Slave configuration. Indicators on the Slave indicate individual Slave Load current and power and Slave status (VOLTS display reads **SLAV** (SLAV)). Slave LOAD switch indicators show engaged (amber) or disengaged (green) status of each slave. Fault indications are displayed on each slave, as well as the master.

### 3.11.6 MASTER/SLAVE OPERATING NOTES/CAUTIONS/WARNINGS

Be sure to read and follow the operating instructions described for a single unit and observe all Cautions and Warnings. A Master/Slave Load configuration is capable of extremely high power and extremely high currents, thus suitable precautions should be taken when using the Load.

- Use optimal damping (see PAR. 3.14 for setup instructions to optimize damping settings), otherwise use factory default settings.
- Interconnect UUT and Load with cabling designed to minimize inductance. Remember that rapidly-changing high-currents combined with inductance produces high-voltage spikes (spikes that can easily damage equipment including the EL Load).
- To minimize spiking and current surges when using computer-controlled remote operation, the best sequence is:
  1. Select Mode (e.g. MODE CARR).
  2. Select very low value set point (e.g. CARR 0.2).
  3. Engage Load (INPUT ON).
  4. Slew Load to desired operating set point (e.g. CARR 105).

### 3.11.7 MASTER/SLAVE DISCONNECT

Once units have been operated in a Master/Slave configuration, they must be reconfigured to restore normal standalone operation. This may be accomplished either from the front panel, or via a computer interface.

**From front panel:** Turn power off to all units, then remove all master/slave cables. Power up all units, wait two minutes, then turn power off and then back on to all units.

**From computer interface:** After three seconds send DIAG:RST to the master unit. Disconnect all master slave cables within 10 seconds or turn off all slaves within 10 seconds and then disconnect the slave cables. If power is not cycled on slaves, send CAL:SLAVEMODE 0 followed by DIAG:RST to each slave. The DIAG:RST command sends back multiple lines of data with the last line having ### at end to indicate the Reset is complete. The GPIB and Ethernet options will be available approximately 2 seconds after receipt of the ###.

### 3.12 OPERATION VIA COMPUTER INTERFACE

The computer interface (either USB, RS-232 optional GPIB or optional Ethernet) can be used to operate the load from a remote location using a computer using IEEE 488.2 and SCPI commands. Refer to Appendices A and B, respectively, for a complete list of applicable commands and queries. The commands INPut 1 (or ON) or OUTput 1 (or ON) are equivalent to using the LOAD switch on the front panel to engage the load; the commands INPut 0 (or OFF) or OUTput 0 (or OFF) are used to disengage the load. Figure 3-1 illustrates the commands used to set the load to operate at 100 Amperes from a 12.5-volt source in the Constant Current mode, engage the load, then disengage the load.

The GPIB interface is a listener and a talker; it can send and receive commands. The factory default GPIB address is 10; refer to Appendix B, PAR. B.82 to change it.

MODE CURR	Sets mode to current.
CURR 0.1	Sets current level to low level.
INPUT ON	Causes load to engage UUT and draw current. LOAD pushbutton illumination changes from green to amber and VOLTS, AMPS and KW displays show measured parameters.
CURR 100	Sets current level to 100 amperes.
MEAS:CURR?	Request that Series EL measure current. Unit responds with 100.0.
MEAS:VOLT?	Request that Series EL measure voltage. Unit responds with 12.5.
INPUT OFF	Causes load to disengage UUT and stop drawing current.

FIGURE 3-1. EXAMPLE OF REMOTE OPERATION

### **3.13 SCPI PROGRAMMING**

SCPI (Standard Commands for Programmable Instruments) is a programming language conforming to the protocols and standards established by IEEE 488.2 (reference document *ANSI/IEEE Std 488.2, IEEE Standard Codes, Formats, Protocols, and Common Commands*). SCPI commands are sent to the Series EL Electronic Load as ASCII output strings within the selected programming language (PASCAL, C, BASIC, LABVIEW, etc.) in accordance with the interface protocol used.

Different programming languages (e.g., BASIC, C, PASCAL, LABVIEW, etc.) have different ways of representing data that is to be put on the control bus. It is up to the programmer to determine how to output the character sequence required for the programming language used. If the optional IEEE 488.2 (GPIB) interface is used, address information (GPIB address) must be included before the command sequence.

#### **3.13.1 SCPI MESSAGES**

There are two kinds of SCPI messages: program messages from controller to electronic load, and response messages from the electronic load to the controller. Program messages consist of one or more properly formatted commands/queries and instruct the electronic load to perform an action; the controller may send a program message at any time. Response messages consist of formatted data; the data can contain information regarding operating parameters, electronic load state, status, or error conditions.

#### **3.13.2 COMMON COMMANDS/QUERIES**

Common commands and queries are defined by the IEEE 488.2 standard to perform overall electronic load functions (such as identification, status, or synchronization) unrelated to specific electronic load operation (such as setting voltage/current). Common commands and queries are preceded by an asterisk (\*) and are defined and explained in Appendix A. Refer also to syntax considerations (PARs 3.13.3.7 through 3.13.6).

4878 48780 38400 191 191 Baud OK

4878 4878

EEPROM Used: 287 bytes

```

78 48 45 4C:20 35 4B 2D:36 30 30 2D:32 30 30 20
30 33 2D 31:35 2D 32 30:31 30 00 00:00 00 00 00
00 00 00 00:00 00 00 00:00 00 00 41:31 30 34 35
30 33 00 00:00 00 00 00:00 00 00 00:00 00 00 00
00 FF 00 00:00 00 00 00:00 00 00 00:00 00 00 00
00 00 00 00:03 28 9A 01:00 50 34 03:00 3C 68 06
00 78 D0 0C:00 40 0D 03:00 05 03 18:31 0C 00 00
00 00 00 C0:27 09 00 80:8D 5B 00 20:12 0A 00 50
34 03 00 D0:1B 50 00 50:50 4D 33 32:30 30 00 00
00 00 00 00:00 00 00 00:00 00 00 00:00 00 00 00
00 00 00 00:00 00 00 00:00 00 00 00:00 00 00 00
02 20 12 0A:00 00 00 00:00 00 00 00:00 40 42 0F
00 01 00 00:00 C8 00 00:00 C8 00 00:00 B8 0B 00
00 94 2A 00:00 28 64 00:00 00 00 00:00 00 00 00
00 00 00 00:00 00 00 00:96 00 00 00:96 00 00 1A
04 00 00 E8:03 00 00 E8:03 00 00 2E:04 00 00 E8
03 00 00 D0:07 00 00 EC:FF 00 00 00:00 00 00 00
00 00 00 00:00 00 00 00:00 00 00 00:00 78 48

```

EL Load boot up diagnostic information verifying communications baud rate and memory check sums.

\*IDN reply. See PAR. A.3 for details.

KEPCO, EL 5K-600-200 03-15-2010,A104503,MCB #234 1.219 \$ 2010/03/26 12:58:08 \$

KEPCO, EL 5K-600-200 03-15-2010,A104503,MCB #234 1.219 \$ 2010/03/26 12:58:08 \$

MEL (chassis) Serial Number: A104503

Calibration Settings

Calibrated Fullscale Ranges

```

100V 105000 mV
200V 210000 mV
400V 419900 mV
800V 839800 mV

```

Cutoffs

```

Current      : 0.200
Voltage      : 0.200
Power        : 0.003

```

```

Max volt limit : 660.0
Max curr limit : 210.0
Max powr limit : 5.250

```

Setpoint scaling factor: 10.90

Setpoint Calibration Factors

```

Voltage      : 1.050
Current      : 1.000
Power        : 1.000
Resistance    : 1.070
Conductance  : 1.000

```

Fan temperature limits (C)

```

Lower        : 40
Upper        : 100

```

External FB Gain : 2.000

Master Delay : -2000 uSec

Load Calibration Configuration Information

Note: These are factory settings and are displayed should diagnostic information be required.

FIGURE 3-2. MASTER/SLAVE START-UP, COMPUTER DISPLAY (SHEET 1 OF 2)

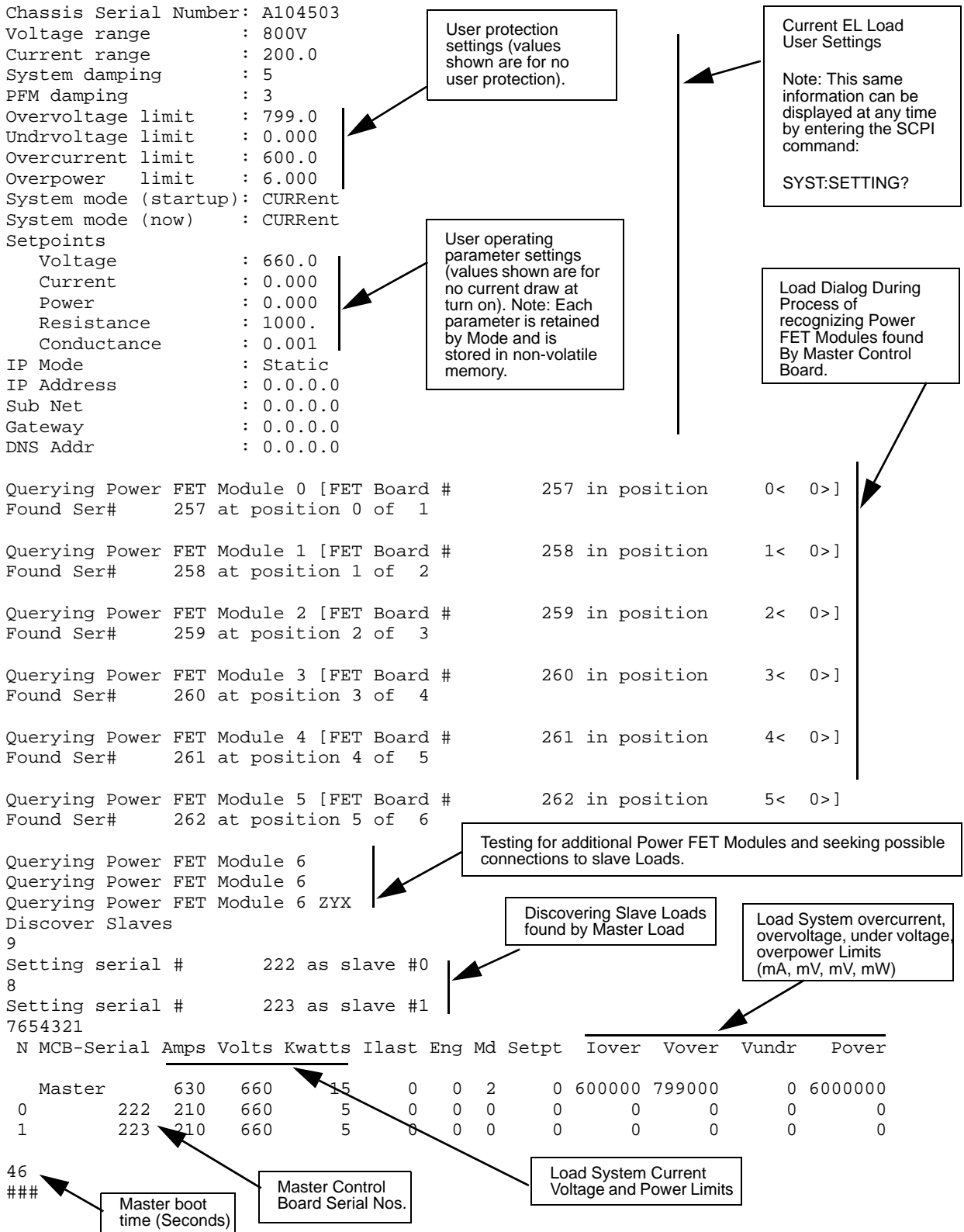

FIGURE 3-2. MASTER/SLAVE START-UP, COMPUTER DISPLAY (SHEET 2 OF 2)

### 3.13.3 SCPI SUBSYSTEM COMMAND/QUERY STRUCTURE

Subsystem commands/queries are related to specific electronic load functions (such as setting voltage, current limit, etc.) Figure 3-3 is a tree diagram illustrating the structure of SCPI subsystem commands used in the EL Series Electronic Load with the “root” at the left side, and specific commands forming the branches. The following paragraphs introduce the subsystems; subsystem commands are defined and explained in Appendix B.

#### 3.13.3.1 DIAGNOSTIC SUBSYSTEM

This subsystem is used to print the SCPI command set.

**TABLE 3-2. REMOTE OPERATION COMMAND SUMMARY**

Command	Function
<b>CONTROL COMMANDS. Terminate command with ? to display established mode.</b>	
MODE CURRent	Enter Constant Current mode
MODE VOLTage	Enter Constant Voltage mode
MODE POWer	Enter Constant Power mode
MODE RESistance	Enter Constant Resistance mode
MODE CONDuctance	Enter Constant Conductance mode
MODE SHORt	Enter Short mode
MODE OFF	Disengage load and enable viewing of Model data.
INPut 1 or INPut ON (alternatively OUT 1)	Engage load (load ON)
INPut 0 or INPut OFF (alternatively OUT 0)	Disengage load (load OFF)
INPut:CUToff:TIME <NR2>	Establishes time to wait for input voltage to recover after input is in Disabled state.
INPut:CUToff:VOLT <NR2>	Establishes minimum input voltage required for engaging the load.
<b>SET PARAMETER LEVEL COMMANDS. Terminate command with ? to display parameter level.</b>	
CURRent <NR2>	Set Current level in Amperes
VOLTage <NR2>	Set Voltage level in Volts
POWer <NR2>	Set Power level in Watts
RESistance <NR2>	Set Resistance level in Ohms
CONDuctance <NR2>	Set Conductance level in Siemens
CONDuctance:TRANSient <value>,<time>,<period>,<count>	Configures a transient conductance pulse.
CURRent:TRANSient <value>,<time>,<period>,<count>	Configures a transient current pulse.
RESistance:TRANSient <value>,<time>,<period>,<count>	Configures a transient resistance pulse.
VOLTage:TRANSient <value>,<time>,<period>,<count>	Configures a transient voltage pulse.
<b>MEASUREMENT QUERIES.</b>	
MEASure:CURRent?	Return Load current in Amperes
MEASure:VOLTage?	Return Load voltage in Volts
MEASure:POWer?	Return Load power in Kilowatts
MEASure:ALL?	Return Load Power, Current and Voltage



**TABLE 3-2. REMOTE OPERATION COMMAND SUMMARY (CONTINUED)**

Command	Function
<b>PROTECTION COMMANDS. Terminate command with ? to display the protection setting for that mode. Exceeding these user-defined protection levels disengages the UUT and displays fault indication (see PAR. 3.3.1.)</b>	
CURRent:PROTection <NR2>	Set maximum Current level in Amperes
VOLTage:PROTection:OVER <NR2>	Set maximum Voltage level in volts
VOLTage:PROTection:UNDer <NR2>	Set minimum Voltage level in volts
POWer:PROTection <NR2>	Set maximum load Power in watts
<b>STATUS CLEAR COMMANDS. Trip error prevents INPut 1 or OUTPut 1 from engaging the load. See STATus:QUEStionable register for error definitions (see PAR. 3.13.7.3)</b>	
CURRent:PROTection:STATe 0	Clear overcurrent error
POWer:PROTection:STATe 0	Clear over power error
VOLTage:PROTection:UNDer:STATe	Clear undervoltage error
VOLTage:PROTection:OVER:STATe	Clear overvoltage error
<b>VOLTMETER RANGE COMMANDS. Terminate command with ? to display the range setting. The voltmeter range is determined by the lower of: the range setting below and the lowest range that includes the current VOLT setting.</b>	
SYSTem:RANGe:VOLTage 100V	Set Voltage measurement range 0 – 100V
SYSTem:RANGe:VOLTage 200V	Set Voltage measurement range 0 – 200V
SYSTem:RANGe:VOLTage 400V	Set Voltage measurement range 0 – 400V
SYSTem:RANGe:VOLTage 800V	Set Voltage measurement range 0 – 800V
<NR2> = Numeric Values with or without a decimal point. Examples: 0.0156, 15.6, 156 or 1.56E+3 (scientific notation: digits with decimal point and exponent).	
NOTE: If commands that expect a boolean are entered without an argument, the argument is interpreted as 0.	

**3.13.3.2 PROTECTION SUBSYSTEM**

This subsystem establishes limits for voltage, current and power.

**3.13.3.3 [SOURCE:]MEASURE SUBSYSTEM**

This query subsystem returns the voltage, current and power measured at the LOAD terminals.

**3.13.3.4 [SOURCE:]INPUT, [SOURCE:]OUTPUT SUBSYSTEMS**

This subsystem controls whether the UUT is engaged (on) or disengaged (off) from the load.

**3.13.3.5 [SOURCE:]VOLTAGE, [SOURCE:]CURRENT, [SOURCE:]POWER SUBSYSTEMS**

These subsystems set the mode and establish setpoints for each mode. Also establish protection limits and the range of the front panel display (VOLTS, AMPS or KW, respectively) for each mode.

**3.13.3.6 [SOURCE:]RESISTANCE, [SOURCE:]CONDUCTANCE SUBSYSTEMS**

These subsystems set the mode and establish setpoints for each mode.



### 3.13.4 PROGRAM MESSAGE STRUCTURE

SCPI program messages (commands from controller to load) consist of one or more *message units* ending in a *message terminator*. The message terminator is not part of the syntax; it is defined by the way your programming language indicates the end of a line: “newline” must be defined as CR (0D<sub>H</sub>) followed by LF (0A<sub>H</sub>). The message unit is a keyword consisting of a single command or query word followed by a message terminator (e.g., CURR?<newline> or INPut<end-of-line>). The message unit may include a data parameter after the keyword separated by a space; the parameter is usually numeric (e.g., CURR 5<newline>), but may also be a string (e.g., OUTP ON<newline>). The following subparagraphs explain each component of the message structure.

Each command must use the full syntax shown in Appendix B. Each command must be a separate line.

#### 3.13.4.1 KEYWORD

Keywords are instructions recognized by a decoder within the EL Series, referred to as a “parser.” Each keyword describes a command function; all keywords used by the EL Series are listed in Figure 3-3.

Each keyword has a long form and a short form. For the long form the word is spelled out completely (e.g. STATUS, OUTPUT and VOLTAGE are long form keywords). For the short form only the first three or four letters of the long form are used (e.g., STAT, OUTP and VOLT). Figure 3-3 shows the short form keywords; both short and long form keywords are found in Appendix B.

#### 3.13.4.2 KEYWORD SEPARATOR

If a command has two or more keywords, adjacent keywords must be separated by a colon (:) which acts as the keyword separator (e.g., SOUR:MEAS:VOLT).

#### 3.13.4.3 QUERY INDICATOR

The question mark (?) following a keyword is a query indicator. This changes the command into a query. If there is more than one keyword in the command, the query indicator follows the last keyword. (e.g., VOLT? and MEAS:CURR?).

#### 3.13.4.4 DATA

Some commands require data to accompany the keyword either in the form of a numeric value or character string. Data always follows the last keyword of a command or query (e.g., SOUR:VOLT:LEV 100 or LOCK OFF).

##### 3.13.4.4.1 MULTIPLE LINE MESSAGES

Some commands return multiple lines of data via the serial or USB port. Each line is separated by a CR LF sequence. The GPIB and LAN interfaces change the line terminators of multiple line messages to “CR,” (CR comma). Each line is a different data element. The longest multiple line message contains 120,000 bytes of information (DIAG:TREE?).

#### 3.13.4.5 DATA SEPARATOR

Data must be separated from the last keyword by a space (e.g., SOUR:VOLT:LEV 100 or LOCK OFF).

### 3.13.4.6 MESSAGE TERMINATOR

The message terminator defines the end of a message. One message terminator is permitted:

- new line (<NL>) is defined as CR (Carriage Return, 0D<sub>H</sub>) followed by LF (Line Feed, 0A<sub>H</sub>)

NOTE: The examples shown in this manual assume a message terminator will be added at the end of each message. Where a message terminator is shown it is represented as <NL> meaning CR (0D<sub>H</sub>) followed by LF (0A<sub>H</sub>).

### 3.13.5 UNDERSTANDING THE COMMAND STRUCTURE

Understanding the command structure requires an understanding of the subsystem command tree illustrated in Figure 3-3. The “root” is located at the top left corner of the diagram. The parser goes to the root if:

- a message terminator is recognized by the parser
- a root specifier is recognized by the parser

*Optional keywords* are enclosed in brackets [ ] for identification; optional keywords can be omitted and the electronic load will respond as if they were included in the message. The root level keyword [SOURce] is an optional keyword. Starting at the root, there are various branches or paths corresponding to the subsystems. The root keywords for the EL Series are :MEASure, :INPut, :OUTPut, [:SOURce], :PROTection, :STATus, and :SYSTem. Because the [SOURce] keyword is optional, the parser moves the path to the next level, so that VOLTage, CURRent, and MEASure commands are at the root level.

Each time the parser encounters a keyword separator, the parser moves to the next indented level of the tree diagram. As an example, the STATus branch is a root level branch that has three sub-branches: OPERation, CHANnel, and QUEStionable.

A command must contain the short form (the part of the command in capital letters in appendix B) or the full command. Commands and values are not case sensitive.

Command strings must be sent as a single message at all times. It is possible to send multiple command/query strings by separating the commands with a CR. If multiple commands and/or queries are sent this way, each response must be separated by a CR.

Commands that change a setting must be preceded or followed by a query. This response must be accepted by the host prior to sending a new command. Example: **volt 10\rvolt?\r\n** changes the voltage setpoint of the EL load (\r is CR and \n is NL).

### 3.13.6 PROGRAM MESSAGE SYNTAX SUMMARY

- Common commands begin with an asterisk (\*).
- Queries end with a question mark (?).
- Program messages consist of a root keyword and, in some cases, one or more message units separated by a colon (:) followed by a message terminator. Several message units of a program message may be separated by a semicolon (;) without repeating the root keyword.
- UPPER case letters in mnemonics are mandatory (short form). Lower case letters may either be omitted, or must be specified completely (long form)  
e.g., **PROTection** (long form) has the same effect as **PROT** (short form).
- Commands/queries may be given in upper/lower case (long form)  
e.g., **SoUrCe** is allowed.
- Text shown between brackets [ ] is optional.  
e.g., **:[SOUR:]VOLT[:LEV][:AMPL]?** has the same effect as **:VOLT?**

### 3.13.7 STATUS REPORTING

The status reporting of the EL Series Electronic Load follows the SCPI and IEEE 488.2 requirements.

#### 3.13.7.1 STATUS REPORTING STRUCTURE

The status reporting of the EL uses multiple status register sets, illustrated in Figure 3-4. These register sets are Channel Status, Channel Summary, Questionable, Operation, Standard Event and Status Byte/Service Request registers. All registers are 16-bit registers except the Standard Event and Status Byte/Service Request registers which are 8 bits. The Channel Status, Operation Status and Questionable registers all have condition registers which are associated with two related registers: an event register which holds unlatched events reported in real-time by the instrument and is cleared by reading the register, and an enable register which allows the contents of the event register to be passed through to set the associated condition register.

#### 3.13.7.2 STANDARD EVENT STATUS REGISTER

The Standard Event registers contains bits (condition register) is as follows:

- 0 - Not Used — always zero.
- 1 - Not Used — always zero.
- 2 - QYE — Query Error
- 3 - DDE — Device Dependent Error
- 4 - EXE — Execution Error
- 5 - CME — Command Error
- 6 - Not Used — always zero.
- 7 - PON — Power On since this bit last read

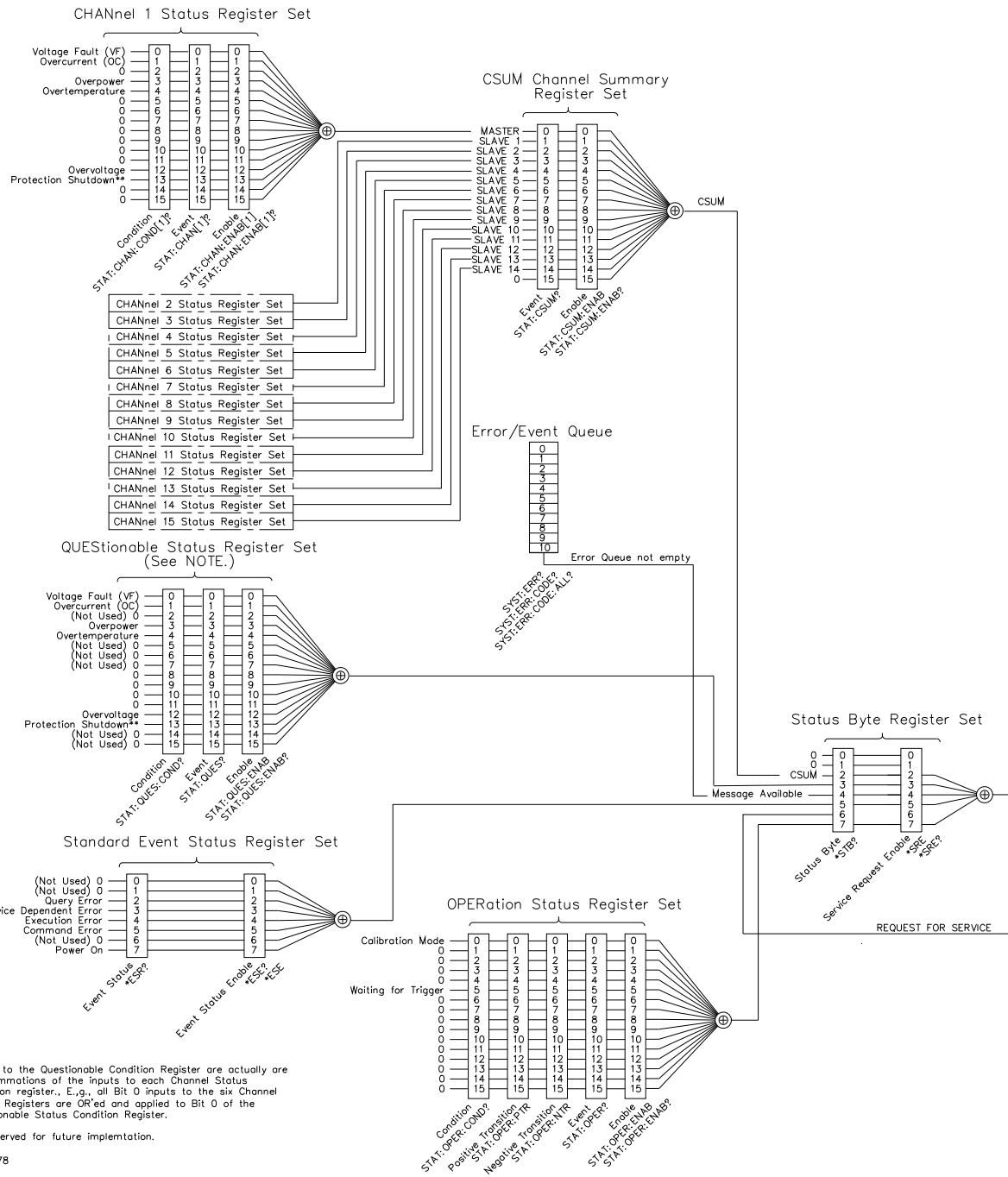

**FIGURE 3-4. STATUS REPORTING STRUCTURE**

### 3.13.7.3 QUESTIONABLE STATUS REGISTER

The QUEStionable condition register (see Figure 3-4) contains status bits representing unusual operation such as inconsistent sensor readings or unusual but non-fault conditions.

- 0 - Voltage Fault (VF) — 1 indicates the Voltage Fault
- 1 - Overcurrent (OC) — 1 indicates overcurrent condition has been detected.
- 2 - Not Used — always zero.
- 3 - Overpower (OP) — 1 indicates power has exceeded the rated maximum.
- 4 - Overtemperature (OT) — 1 indicates overtemperature condition has been detected.
- 5 - 7 - Not Used — always zero.
- 8 - Not Used — always zero.
- 9 - Not Used — always zero.
- 10 - Not Used — always zero.
- 11 - Not Used — always zero.
- 12 - Overvoltage (OV) — 1 indicates overvoltage condition has been detected.
- 13 - Protection Shutdown (PS) — 1 indicates protection shutdown has occurred
- 14 - 15 - Not Used — always zero.

### 3.13.7.4 CHANNEL STATUS REGISTER

The Channel Status registers (see Figure 3-4), one for each parallel-connected load, reflect the state of each load

- 0 - Voltage Fault (VF) — 1 indicates the Voltage Fault
- 1 - Overcurrent (OC) — 1 indicates overcurrent condition has been detected.
- 2 - Not Used — always zero.
- 3 - Overpower (OP) — 1 indicates power has exceeded the rated maximum.
- 4 - Overtemperature (OT) — 1 indicates overtemperature condition has been detected.
- 5 - 7 - Not Used — always zero.
- 8 - Not Used — always zero.
- 9 - Not Used — always zero.
- 10 - Not Used — always zero.
- 11 - Not Used — always zero.
- 12 - Overvoltage (OV) — 1 indicates overvoltage condition has been detected.
- 13 - Protection Shutdown (PS) — 1 indicates protection shutdown has occurred
- 14 - 15 - Not Used — always zero.

### 3.13.7.5 CHANNEL SUMMARY REGISTER

The Channel Summary registers (see Figure 3-4), store the OR'ed output of each Channel status register.

- 0 - MASTER
- 1 - SLAVE 1  
through
- 14 - SLAVE 14
- 15 - Not Used — always zero.

### 3.13.7.6 STATUS BYTE REGISTER

The Status Byte registers (see Figure 3-4), essentially determine which lower-level summary conditions can generate a Service Request.

- 0 - 1 - Not Used — always zero.
- 2 - CSUM — Channel Summary, logical OR of enabled channels in the Channel Summary registers.
- 3 - QUES — Questionable Status, logical OR of enabled conditions in the Questionable Status registers
- 4 - MAV — Message Available, set if an error message is available in the Message Queue.
- 5 -ESB — Event Status Summary, set if an enabled standard event occurs.
- 6 - MSS — Master Status Summary.
- 7 - OPER — Operation Status Summary, set if an Operation event occurs.

## 3.14 DAMPING

Typical operation for an electronic load involves the flow of high currents. Often these currents flow through long interconnections. The combination of high, rapidly changing currents and the inductance associated with connections to the load can cause unexpected results, such as very high voltage spikes, oscillation or severe ringing (damped oscillations) at the source.

To help reduce these issues, the Series EL offers multiple forms and degrees of damping to allow the best measurements possible.

There are two forms of damping in the Series EL load: 1) System Damping, which dampens the response of the main control loop and 2) Mode Damping that dampens effects at the Power FET Modules by modifying the individual FET loop characteristics. Increased system damping reduces the tendency for oscillation and reduces response time to high speed transients. Increased Mode damping decreases the loop's response time to transients. These two damping functions have a great deal of interplay. For best results, follow the guidelines of PAR. 3.14.1 and the procedure of PAR. 3.14.2.



### 3.14.1 DAMPING ADJUSTMENTS

The factory default settings for damping sets the overall system damping at maximum and the Power FET Module damping at mid-level. It should be noted that once changed, these damping settings are stored in non-volatile memory; the new values are retained until changed again. For most applications the factory settings should provide optimum damping, however, if you have a special situation, damping adjustments are best made using a test set up as shown in Figure 3-5.

Figure 3-6 shows various waveforms that may appear at the current monitor output (I-Load) when the load is connected to a high current source and the current drawn from the source changes rapidly following a square wave (or pulse) source connected to the E-Load input. Figure 3-6 shows the effects of changing both the System Damping and the Mode Damping. The exact waveforms that will be seen are highly dependent on the nature of the source, the inter-connecting cables and the various damping setting.

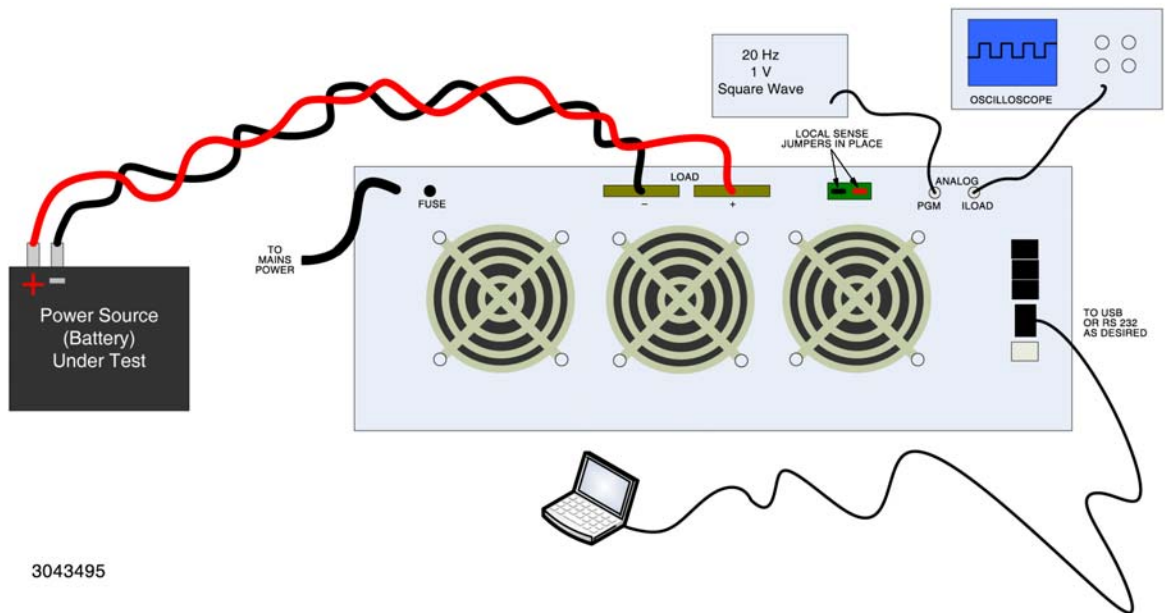

FIGURE 3-5. DAMPING MEASUREMENT SETUP

### 3.14.2 RECOMMENDED DAMPING ADJUSTMENT PROCEDURE

Damping adjustments are made using either the front panel or the SCPI Commands found in Appendix B via either the RS-232 or USB remote interface.

System and Mode (PFM) Damping are adjusted using either the procedure detailed in PAR, 3.14.3 (front panel) or the SYST:DAMP (see PAR. B.93) and SYST:PFM:DAMP (see PAR. B.102) command commands via remote interface. Refer to the respective paragraphs as necessary.

Figure 3-6 shows sample waveforms of a properly damped EL (A) and an improperly damped EL (B, C, D). The goal is to attain a waveform looking like A. This may not be possible and the best that can be accomplished is C with the smallest overshoots. The waveform can be

observed using an oscilloscope connected to the ILOAD connector (Figure 3-5) or pin 1 (pin 15 return) of the Analog Control connector for dual channel units.

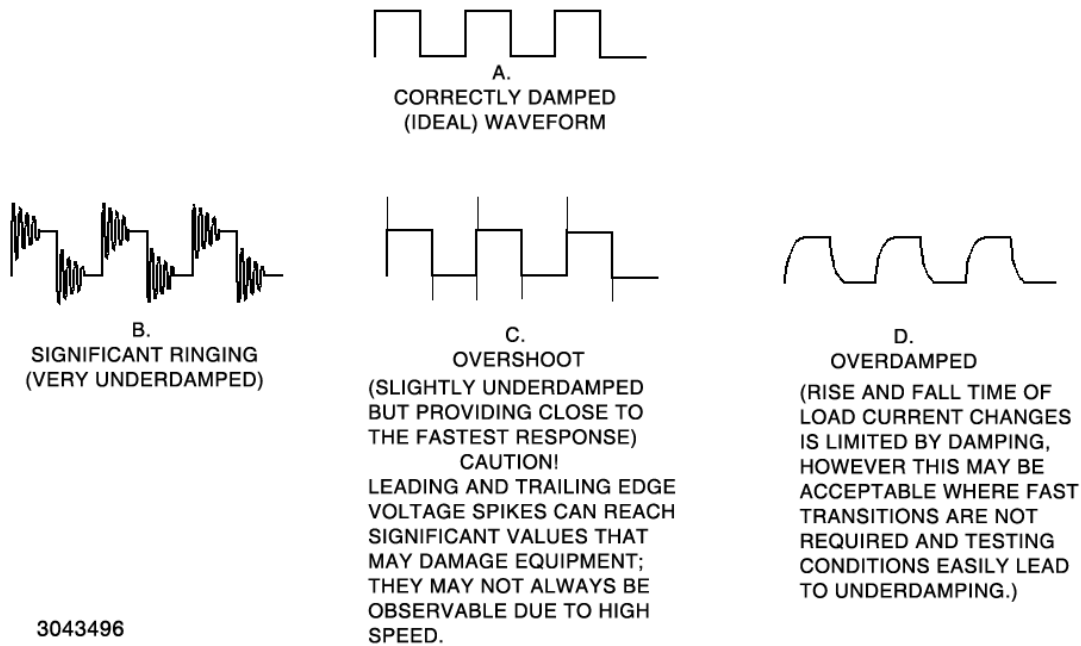

FIGURE 3-6. DAMPING WAVEFORMS

Before starting to adjust damping, set system damping to 0. **NOTE: Ramps must be turned off before adjusting damping, otherwise the unit will generate an overdamped waveform similar to D.**

When modifying the damping settings, a good approach is to start with system damping at 5 and Mode (PFM) damping set to 4. System damping is the coarse adjustment: higher numbers cause overdamping and lower numbers cause significant ringing. If the waveform resembles B, then increase the System damping value. If the waveform resembles D, then reduce the System damping value until the waveform resembles A as closely as possible. The valid values for System damping are 1 through 7 for units having a Firmware Version suffix B3 or higher, and 1 through 5 for units having a Firmware Version suffix B2 or lower. Firmware Version can be viewed either from the front panel (see PAR. 3.7) or remotely using \*IDN? (see PAR. A.6). If waveform C is the best that can be attained using System damping, then use Mode (PFM) damping to reduce the overshoots to the smallest value possible.

A test plan should anticipate potential conditions that may cause an under-damped response to transitions. Some basic steps taken at setup may help minimize problems:

- Where possible, use short cables between the source (UUT) and the load.
- Maximize the size of the cables to minimize both resistance and inductance.
- Twist the positive and negative cables together to provide as much cancelation of inductance as possible.

- When using batteries, ensure they are fully charged when possible. Many styles of batteries (especially lead-acid batteries) have a tendency to oscillate when excited by fast rise-time transients. The sudden change in current causes the battery plates to warp slightly, thus changing capacitance which interacts with the inductance of the cables.

### 3.14.3 DAMPING PROCEDURE USING FRONT PANEL CONTROLS

The following procedure provides the details of how to use the front panel to accomplish System and Mode (PFM) damping directly from the front panel. Before proceeding, refer to PAR. 3.14, 3.14.1 and 3.14.2 for the setup and a full understanding of successful damping.

1. With the load disengaged (LOAD pushbutton indicator steady green) press the LOAD pushbutton to engage the load (LOAD pushbutton indicator goes from green to amber).
2. Push and hold for CONTROL knob for three seconds, until the LOAD pushbutton indicator starts blinking alternately green and amber, then release CONTROL knob.
3. Rotate CONTROL knob to select OFF mode (CI, CR, CV and CP indicators are all off), then tap the LOAD pushbutton. The LOAD pushbutton indicator blinks alternately green and off.
4. Rotate CONTROL knob until **8888** (DAMP) is shown in AMPS display, VOLTS display shows the System damping value and KW display shows the Mode (PFM) damping value.
5. To change damping values, tap CONTROL knob. VOLTS display shows **5458** (SYST) and KW display shows a blinking digit representing the System damping value.
6. Rotate CONTROL knob to change system damping value, then tap CONTROL knob to accept. VOLTS display shows **8888** (PFM) and the KW display shows a blinking digit representing the Mode (PFM) damping value.
7. Rotate CONTROL knob to change PFM damping value, then tap CONTROL knob to accept. AMPS display shows **8888** (RAMP).
8. Tap the LOAD pushbutton to exit the menu (LOAD pushbutton changes to steady green) and returns to OFF mode.

### 3.15 PROGRAMMING TIME REQUIRED TO CHANGE STATE (RAMPS)

The EL Load allows the user to ease the transition from one state to another by using the front panel RAMP menu to set the time for three ramps:

POS: Time (from 0 to 2 seconds) required to change to a more positive state.

NEG: Time (from 0 to 2 seconds) required to change to a more negative state.

INPT: Time (from 0 to 2 seconds) to reach operating mode setpoint after engaging the load.

Ramps work in all modes except power. The three ramps each consist of up to 4000 evenly spaced steps of 4.5 microseconds to 2.50 milliseconds to achieve the ramp time programmed (maximum ramp time is 2 seconds). The ramp will either step from one level to the other in 4.5 microsecond steps (the minimum step time) or will execute approximately 4000 steps within a time required to meet the ramp duration. For example, a ramp of 1 millisecond consists of 222 steps (4.5 microseconds per step). A ramp of 20 milliseconds consists of 4000 steps (25 microseconds per step). A ramp of 2 seconds (maximum) consists of 4000 steps (0.5 milliseconds per step).

### 3.15.1 RAMP DETAILS

NOTE: The following discussion can also apply to the use of SCPI commands via a remote interface to program the ramps. The front panel POS ramp is programmed using SYST:RAMP:POS (PAR. B.108), NEG ramp is programmed using SYST:RAMP:NEG (PAR. B.110), and INPT ramp is programmed using INP:RAMP (PAR. B.15).

POS and NEG ramps establish the time it takes for the load to go from one setpoint to another. Figure B-1 of Appendix B shows typical timing when POS and NEG ramps are used with transients to change state (see PAR B.100 for details on transients).

INPT ramp establishes the time it takes to attain the operating mode setpoint value once the load is engaged. For current and conductance modes, the ramp starts at zero and increases in even steps over the duration established by the INPT time until the setpoint is reached. For voltage and resistance modes the ramp starts at maximum and decreases to the setpoint value. The INPT ramp does not function in Power mode. Units are shipped from the factory with INPT set to 0.02 seconds (the recommended minimum).

With INPT ramp time set between 0.001 and 2, the INPT ramp occurs when the LOAD switch is pressed to engage the load. This ramp can also occur if a minimum input voltage and recovery time has been programmed (see PAR. 3.16). If input voltage is lost, then rises above the cutoff point within the recovery period, the INPT ramp occurs. Figure 3-7 shows the timing for INPT ramps.

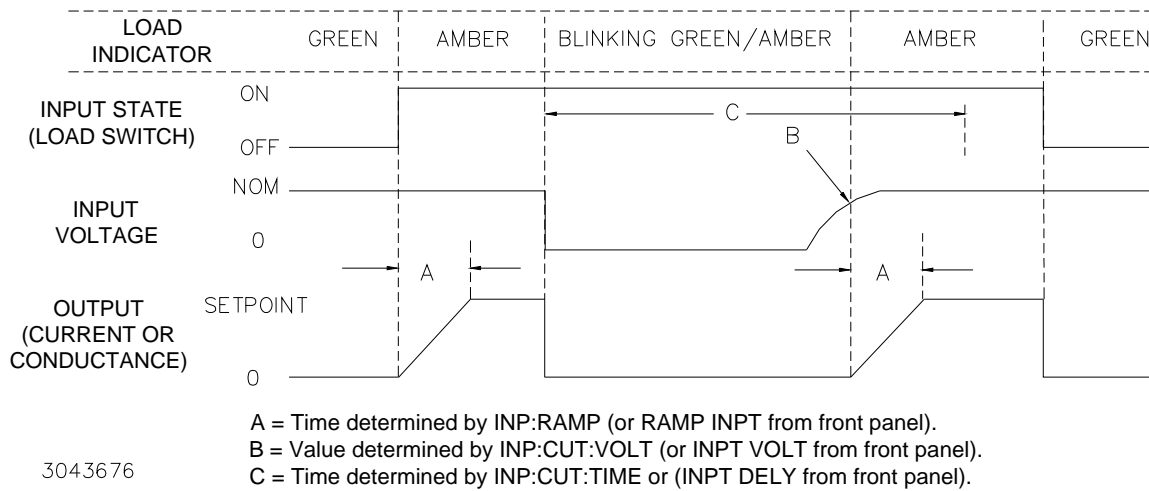

3043676

FIGURE 3-7. TIMING FOR PROGRAMMING INPT RAMP AND MINIMUM VOLTAGE

### 3.15.2 RAMP INTERACTIONS

- If the INPT ramp is in use, and POS and/or NEG ramps are also used, the actual INPT ramp will be the larger of the values programmed for INPT, POS and NEG.

When using both ramps and transients at the same time, the following must be observed (see Figure B-1 for timing, see PAR. B.100 to initiate a transient pulse.):

- Transient <value> must be greater than set point if POS ramp and NEG ramp times are different.
- Transient pulse period <time> must exceed POS ramp time by at least 1 millisecond.
- Transient <period> must be greater than (POS ramp time + NEG ramp time + 0.002)
- To configure Transient see PAR. B.30 for conductance, PAR. B.38 for current, PAR. B.50 for resistance and PAR. B.62 for voltage.
- Programming minimum input voltage (PAR. 3.16) to any value will disable the output and reduce overshoot at the start of the INPT ramp.

### 3.15.3 ACCESSING RAMPS FROM THE FRONT PANEL

1. With the load disengaged (LOAD pushbutton indicator steady green) press the LOAD pushbutton to engage the load (LOAD pushbutton indicator goes from green to amber).
2. Push and hold for CONTROL knob for three seconds, until the LOAD pushbutton indicator starts blinking alternately green and amber, then release CONTROL knob.
3. Rotate CONTROL knob to select OFF mode (CI, CR, CV and CP indicators are all off), then tap the LOAD pushbutton. The LOAD pushbutton indicator blinks alternately green and off.
4. Rotate CONTROL knob until **RAMP** (RAMP) is shown in AMPS display, VOLTS display shows the Positive Ramp value and KW display shows the Negative Ramp value.
5. To change Ramp values, tap CONTROL knob. VOLTS display shows **POS** (POS) and KW display shows the positive ramp value with one digit blinking.
6. Rotate CONTROL knob to change value. Tap CONTROL knob to move to the next digit. Once the desired value for POS ramp is displayed, continue to tap until VOLTS display shows **NEG** (NEG) and KW display shows the negative ramp value with one digit blinking.
7. Rotate CONTROL knob to change value. Tap CONTROL knob to move to the next digit. Once the desired value for POS ramp is displayed, continue to tap until VOLTS display shows **INPT** (INPT) and KW display shows the input ramp value with one digit blinking.
8. Rotate CONTROL knob to change value. Tap CONTROL knob to move to the next digit. Once the desired value for input ramp is displayed, continue to tap until AMPS display no longer shows **RAMP** (RAMP).
9. Tap the LOAD pushbutton to exit the menu (LOAD pushbutton changes to steady green) and returns to OFF mode.

### 3.16 MINIMUM INPUT VOLTAGE

The EL Series allows the user to establish a minimum input voltage required to keep the load engaged. When the input voltage falls below the minimum, the load will automatically disengage. The user can also program a delay, which establishes a time for input voltage to recover (exceed the minimum programmed) before disengaging the load. This can be done either from the front panel or by using SCPI commands via a remote interface.

Figure 3-7 illustrates timing for minimum input voltage programming. If input voltage from the UUT (unit under test) drops below the minimum input voltage, the input is disabled (set to 0 for current and conductance, set to maximum for voltage and resistance, all FET's are off). The LOAD indicator blinks green/amber while the input is disabled. If the voltage increases above minimum input voltage (B, Figure 3-7) while the input is disabled, the load is engaged, the input is enabled and the load returns to the previous setpoint. The LOAD indicator changes to steady amber indicating the load is once again engaged.

If the delay is set to 0 the input will stay in the disabled state until either input voltage recovers, or the LOAD switch is pressed to disengage the LOAD. If a time delay other than 0 is implemented, the input will be automatically set to off if the input voltage has not recovered when the time delay expires.

#### 3.16.1 PROGRAMMING MINIMUM INPUT VOLTAGE FROM THE FRONT PANEL

1. With the load disengaged (LOAD pushbutton indicator steady green) press the LOAD pushbutton to engage the load (LOAD pushbutton indicator goes from green to amber).
2. Push and hold for CONTROL knob for three seconds, until the LOAD pushbutton indicator starts blinking alternately green and amber, then release CONTROL knob.
3. Rotate CONTROL knob to select OFF mode (CI, CR, CV and CP indicators are all off), then tap the LOAD pushbutton. The LOAD pushbutton indicator blinks alternately green and off.
4. Rotate CONTROL knob until **INPE** (INPT) is shown in AMPS display, VOLTS display shows the minimum input voltage value (in volts) and KW display shows the time delay (time allowed for input voltage to recover before the load is disengaged) in Seconds.
5. To change Minimum Input Voltage value or Delay time, tap CONTROL knob. VOLTS display shows **VOLT** (VOLT) and KW display shows the minimum voltage value with one digit blinking.
6. Tap CONTROL knob to continue without changing value, or rotate CONTROL knob to change value. Tap CONTROL knob to move to the next digit. Continue using CONTROL knob to set all digits, then tap CONTROL knob to continue.
7. VOLTS display shows **DELY** (DELY) and KW display shows the time delay with one digit blinking. The time delay is the time to wait for input voltage to recover (exceed the minimum) before disengaging the load. When set to 0 the unit will disable input ramp.
8. Tap CONTROL knob to continue without changing value, or rotate CONTROL knob to change value. Tap CONTROL knob to move to the next digit. Continue using CONTROL knob to set all digits,
9. Tap the LOAD pushbutton to exit the menu (LOAD pushbutton changes to steady green) and returns to OFF mode.

### **3.17 ANALOG PROGRAMMING**

The Analog input applied to either  $\pm$ REF IN terminals (non-isolated, hazardous) or ANALOG CONTROL pins 2 and 7 (isolated, SELV), is summed with the digital setpoint value.  $\pm$ REF IN terminals are enabled at the factory (default); refer to PAR. B.96 to change the external programming source. Refer to PAR. 2.6.5 for analog input signal details. A positive Analog input voltage increases the digitally determined setpoint, a negative voltage decreases the digitally determined setpoint.

Analog programming is summed with the digital setpoint. This feature can be used to allow a waveform to ride on a d-c level. The sum of the analog input signal and the digital setpoint must produce a result that is either 0 or positive, since the load can not control current in the negative direction.

For example, for the EL 5K-400-400 in CI Mode, if the digital setpoint is zero, a 0 to 10V signal applied to the Analog input adjusts the controlled parameter (current) from 0 to full scale (400A). However, if the digital setpoint is set to 200A,  $\pm$ 5V applied to the Analog input allows current from 0A (-5V) to 400A (+5V).

For Master/Slave configurations, the Analog input programming signal must be simultaneously applied to all parallel-connected units.

### **3.18 OPERATOR MAINTENANCE**

No scheduled maintenance is required, other than to keep the high current connections tight and to ensure all airways are clear of obstructions that could cause the load to overheat during operation at higher power. Calibration Verification should be performed yearly or as required.

The exterior of the load should be cleaned periodically, as is necessary, using a soft cloth dampened with a mild, non-abrasive, water-soluble detergent, and then rinsed with a water-dampened soft cloth.





## APPENDIX A - IEEE 488.2 COMMAND/QUERY DEFINITIONS

### A.1 INTRODUCTION

This appendix defines the IEEE 488.2 commands and queries used with the Series EL Electronic Load. These commands and queries are preceded by an asterisk (\*) and are defined and explained in PARs. A-1 through A.11, arranged in alphabetical order. Table A-1 provides a quick reference of all IEEE 488.2 commands and queries supported in the Series EL Electronic Load. NOTE: Message terminator requires CR and LF (see PAR. 3.13.5).

**TABLE A-1. IEEE 488.2 COMMAND/QUERY INDEX**

COMMAND	PAR.	COMMAND	PAR.
*CLS	A.2	*RST	A.7
*ESE, ?	A.3, A.4	*SRE, ?	A.8, A.9
*ESR?	A.5	*STB?	A.10
*IDN?	A.6	*WAI	A.11

### A.2 \*CLS — CLEAR STATUS COMMAND

**\*CLS**

Syntax: \*CLS

Description: **Clears status data.** Clears the following registers without affecting the corresponding Enable Registers: Standard Event Status Register (ESR), Operation Status Event Register, Questionable Status Event Register, and Status Byte Register (STB). Also clears the Error Queue.

### A.3 \*ESE — STANDARD EVENT STATUS ENABLE COMMAND

**\*ESE**

Syntax: \*ESE <integer> where <integer> = positive whole number: 0 to 255 per Table A-2.  
Default Value: 0

Description: **This command programs the standard Event Status Enable register bits.** The contents function as a mask to determine which events of the Event Status Register (ESR) are allowed to set the ESB (Event Summary Bit) of the Status Byte Register. Enables the Standard events to be summarized in the Status Byte register (1 = set = enable function, 0 = reset = disable function). All of the enabled events of the standard Event Status Enable register are logically ORed to cause ESB (bit 5) of the Status Byte Register to be set (1 = set = enable, 0 = reset = disable).

**TABLE A-2. STANDARD EVENT STATUS ENABLE REGISTER AND STANDARD EVENT STATUS REGISTER BITS**

CONDITION	PON	NU	CME	EXE	DDE	QUE	NU	NU
BIT	7	6	5	4	3	2	1	0
VALUE	128	64	32	16	8	4	2	1

CME	Command Error
DDE	Device Dependent Error
EXE	Execution Error
NU	(Not Used)
PON	Power On
QUE	Query Error

## \*ESE?

### A.4 \*ESE? — STANDARD EVENT STATUS ENABLE QUERY

Syntax: \*ESE?                      Return value: Integer> value per Table A-2.

Description: **Returns the mask stored in the Standard Event Status Enable Register.** Contents of Standard Event Status Enable register (\*ESE) determine which bits of Standard Event Status register (\*ESR) are enabled, allowing them to be summarized in the Status Byte register (\*STB). All of the enabled events of the Standard Event Status Enable Register are logically ORed to cause ESB (bit 5) of the Status Byte Register to be set (1 = set = enable function, 0 = reset = disable function).

## \*ESR?

### A.5 \*ESR? — EVENT STATUS REGISTER QUERY

Syntax: \*ESR?  
Return value: <integer> (Value = contents of Event Status register as defined in Table A-2.)

Description: **Causes the electronic load to return the contents of the Standard Event Status register. After it has been read, the register is cleared.** The Standard Event Status register bit configuration is defined in Table A-2 (1 = set, 0 = reset). The error bits listed in Table A-2 are also related to error codes produced during parsing of messages and to errors in the load (see PAR. B.95).

- Any 1xx type error sets the Command error bit (5).
- Any 2xx type error sets the Execution error bit (4).
- Any 3xx type error sets the Device error bit (3).
- Any 4xx type error sets the Query error bit (2).

## \*IDN?

### A.6 \*IDN? — IDENTIFICATION QUERY

Syntax: \*IDN?  
Return value: Character string

Description: **Identifies the instrument.** This query requests identification. The electronic load returns a string (see example below) which contains the manufacturer name, the model, the serial number and the firmware level. The character string contains the following fields: <Manufacturer>, <Model> <Warranty Date>,<Serial Number>,MCB (Main Control Board) Serial number> <Firmware>-<Suffix> \$ <Date> where: <Manufacturer> = KEPCO, <Model> =EL model (see Table 1-1), <Firmware = MCB Firmware revision no.>, <suffix> = B[n], or C and <Date> = Date and Time of MCB Firmware compilation.

KEPCO, EL 5K-600-200 03-15-2010,A104503,MCB #234 3.87-B3 \$ 2010/03/26 12:58:08 \$

<suffix> = B where:

n≤2 identifies older units that have upgraded firmware. SYST:DAMP (PAR. B.93) for these units can be set only from 0 to 5.

n≥3 identifies older units that have upgraded firmware. SYST:DAMP (PAR. B.93) for these units can be set to any value in the full range from 0 to 7.

<suffix> = C identifies units that are CE marked

# \*RST

## A.7 \*RST — RESET COMMAND

Syntax: \*RST

Description: **Causes system reset of EL Load.** \*RST causes the unit to be reset as follows.

- VOLT:PROT:OVE Overvoltage protection set to rated overvoltage protection limit of the Load.
- VOLT:PROT:UND Undervoltage protection set to 0.
- CURR:PROT Current Protection set to rated overcurrent protection limit of the load. or load system when in Master/slave operation.
- POW:PROT Power protection set to rated overpower protection of the load or load system when in master/slave operation.
- CURR Current set to 0.
- VOLT Voltage set to maximum voltage of load.
- POW Power set to 0.
- RES Resistance set to 1000 ohms.
- COND Conductance set to .001.
- INP Input set to off.
- MODE Mode set to current.
- SYST:REPLY set to off.

No other features are affected by \*RST command.

## A.8 \*SRE — SERVICE REQUEST ENABLE COMMAND

# \*SRE

Syntax: \*SRE <integer> where <integer> = value from 0 - 255 per Table A-3, except bit 6 cannot be programmed.

Description: **Sets the condition of the Service Request Enable register.** The Service Request Enable register determines which events of the Status Byte Register are summed into the MSS (Master Status Summary) and RQS (Request for Service) bits. RQS is the service request bit that is cleared by a serial poll, while MSS is not cleared when read. A "1" (1 = set = enable, 0 = reset = disable) in any Service Request Enable register bit position enables the corresponding Status Byte bit to set the RQS and MSS bits. All the enabled Service Request Enable register bits then are logically ORed to cause Bit 6 of the Status Byte Register (MSS/RQS) to be set.

**TABLE A-3. SERVICE REQUEST ENABLE AND STATUS BYTE REGISTER BITS**

CONDITION	OPER	MSS RQS	ESB	MAV	QUES	CSUM	NU	NU
BIT	7	6	5	4	3	2	1	0
VALUE	128	64	32	16	8	4	2	1

ESB Event Status Byte summary  
 MAV Message available  
 MSS Master Status Summary  
 NU (Not Used)  
 OPER Operation Status Summary  
 QUES QUEStionable Status Summary  
 RQS Request for Service

**A.9 \*SRE? — SERVICE REQUEST ENABLE QUERY**

**\*SRE?**

Syntax: \*SRE? Response: <integer> = value from 0 - 255 per Table A-3.

Description: **Reads the Service Enable Register.** Used to determine which events of the Status Byte Register are programmed to cause the electronic load to generate a service request (1 = set = function enabled, 0 = reset = function disabled). Related Commands: \*SRE, \*STB?

**A.10 \*STB? — STATUS BYTE REGISTER QUERY**

**\*STB?**

Syntax: \*STB? Response: <integer> value from 0 to 255 per Table A-3.

Description: **Reads Status Byte Register without clearing it.** This Query reads the Status Byte Register (bit 6 = MSS) without clearing it (1 = set = function enabled, 0 = reset = function disabled). The register is cleared only when subsequent action clears all set bits. MSS is set when the electronic load has one or more reasons for requesting service. (A serial poll also reads the Status Byte Register, except that bit 6 = RQS, not MSS; and RQS will be reset.)

**A.11 \*WAI — WAIT COMMAND**

**\*WAI**

Syntax: \*WAI

Description: Causes the load to wait until all previously issued commands and queries are complete before executing subsequent commands or queries. This command can be used to guarantee sequential execution of commands and queries. When all pending operations are complete (all previous commands have been executed, the WAI command is completed and execution of subsequent commands can continue.

## APPENDIX B - SCPI COMMAND/QUERY DEFINITIONS

### B.1 INTRODUCTION

This appendix defines the SCPI subsystem commands and queries used with the Series EL Electronic Load. Subsystem commands are defined in PAR. B.9 through B.122, arranged alphabetically in groups as they appear in the tree diagram, Figure 3-3. Table B-1 provides a quick reference of all SCPI subsystem commands and queries used in the EL Load. NOTE: Message terminator requires CR and LF (see PAR. 3.13.5).

**TABLE B-1. SCPI SUBSYSTEM COMMAND/QUERY INDEX**

COMMAND	PAR.	COMMAND	PAR.
DIAG RES	B.3	[SOUR:]VOLT:PROT:OVER, ?	B.54, B.55
DIAG:TREE:DISP	B.4	[SOUR:]VOLT:PROT:OVER:STAT[:LEV], ?	B.56, B.57
DIAG:TREE:SEP, ?	B.5, B.6	[SOUR:]VOLT:PROT:UND, ?	B.58, B.59
LOCK, ?	B.7, B.8	[SOUR:]VOLT:PROT:UND:STAT[:LEV], ?	B.60, B.61
[SOUR:]INP[:STAT], ?	B.9, B.10	[SOUR:]VOLT:TRAN, ?	B.62, B.63
[SOUR:]INP:CUT:TIME, ?	B.11, B.12	STAT:CHAN[:EVENT]?	B.64
[SOUR:]INP:CUT:VOLT, ?	B.13, B.14	STAT:CHAN:COND, ?	B.65, B.66
INP:RAMP, ?	B.15, B.16	STAT:CHAN:ENAB, ?	B.67, B.68
[SOUR:]INP:PROT:CLE	B.17	STAT:CSUM[:EVENT]?	B.69
[SOUR:]INP:SHOR[:STAT]	B.18	STAT:CSUM:ENAB, ?	B.70, B.71
[SOUR:OUTP[:STAT], ?	B.19, B.20	STAT:OPER[:EVENT]?	B.72
[SOUR:]OUTP:PROT:CLE	B.21	STAT:OPER:COND?	B.73
[SOUR:]OUTP:SHOR[:STAT]	B.22	STAT:OPER:ENAB, ?	B.74, B.75
[SOUR:]MEAS:ALL	B.23	STAT:OPER:NTR	B.76
[SOUR:]MEAS:ALL2	B.24	STAT:OPER:PTR	B.77
[SOUR:]MEAS[:SCAL]:CURR[:DC]	B.25	STAT:QUES[:EVENT]?	B.78
[SOUR:]MEAS[:SCAL]:POW[:DC]	B.26	STAT:QUES:COND?	B.79
[SOUR:]MEAS[:SCAL]:VOLT[:DC]	B.27	STAT:QUES:ENAB, ?	B.80, B.81
[SOUR:]COND[:LEV][:IMM][:AMP], ?	B.28, B.29	SYST:COMM[:GPIB]:ADDR, ?	B.82, B.83
[SOUR:]COND:TRAN, ?	B.30, B.31	SYST:COMM:ECHO, ?	B.84, B.85
[SOUR:]CURR[:LEV][:IMM][:AMP], ?	B.32, B.33	SYST:COMM:LAN:IPAD, ?	B.86, B.87
[SOUR:]CURR:PROT, ?	B.34, B.35	SYST:COMM:LAN:MAC?	B.88
[SOUR:]CURR:PROT:STAT[:LEV], ?	B.36, B.37	SYST:COMM:LAN:MODE, ?	B.89, B.90
[SOUR:]CURR:TRAN, ?	B.38, B.39	SYST:COMM:LAN:SUBN, ?	B.91, B.92
[SOUR:]MODE, ?	B.40, B.41	SYST:DAMP, ?	B.93, B.94
[SOUR:]POW[:LEV][:IMM][:AMP], ?	B.42, B.43	SYST:ERR?	B.95
[SOUR:]POW:PROT, ?	B.44, B.45	SYST:EXT, ?	B.96, B.97
[SOUR:]POW:PROT:STAT[:LEV], ?	B.46, B.47	SYST:FAN, ?	B.98, B.99
[SOUR:]RES[:LEV][:IMM][:AMP],	B.48, B.49	SYST:MODE, ?	B.100, B.101
RES:TRAN, ?	B.50, B.51	SYST:PFM, ?	B.102, B.103
[SOUR:]VOLT[:LEV][:IMM][:AMP], ?	B.52, B.53	SYST:PFM:LIST?	B.104

**TABLE B-1. SCPI SUBSYSTEM COMMAND/QUERY INDEX (CONTINUED)**

COMMAND	PAR.	COMMAND	PAR.
SYST:PFM:STAT?	B.105	SYST:RANG:VOLT, ?	B.116, B.117
SYST:RAMP, ?	B.106, B.107	SYST:REPLY, ?	B.118, B.119
SYST:RAMP:POS, ?	B.108, B.109	SYST:SERN?	B.120
SYST:RAMP:NEG, ?	B.110, B.111	SYST:SETT?	B.121
SYST:RANG:CURR, ?	B.112, B.113	SYST:VERS?	B.122
SYST:RANG:POW, ?	B.114, B.115		

## B.2 NUMERICAL VALUES AND DATA CONVENTIONS

The following conventions are used throughout this Appendix.

- < > Items in these brackets are parameter abbreviations. Parameters may be numbers or text
- <NR1> Simple numbers (without a decimal point) from 0 - 255. Examples: 156, 0 or 1
- <NR2 > Numeric Values with or without a decimal point. Examples: 0.0156, 15.6, 156 or 1.56E+3 (scientific notation: digits with decimal point and exponent)
- <txt> Text data. For example, operating modes: CURRent, VOLTage, POWer, RESistance, CONDuctance, SHORt
- <bool> Boolean Data. Examples: 0, 1, OFF or ON. NOTE: If a command expecting a boolean argument is sent with no argument, the argument is assumed to be 0 (e.g., INPut and INPut 0 are identical).
- [ ] Optional keywords are shown in square brackets. For example [SOURce:]INPut:[STATe] <bool> means SOURce and STATe: may be omitted thus the command is reduced to INP <bool>.

## B.3 DIAGnostic:RESet COMMAND

## DIAG:RES

Syntax: Short Form: DIAG:RES Long Form: DIAGnostic:RESet

Description: **Allows user to change operation of \*RST from SCPI to PPM mode.** PPM mode is provided to provide backward compatibility with earlier versions of EL Load Firmware.

\*RST in PPM mode causes a full reboot of the EL load. During the reboot, data is sent by the EL load to the host interface (similar to that shown in Figure 3-2). The data must be received in order for the EL load to function normally (this can be as many as 50,000 characters, taking minutes to complete). Wait at least 200 milliseconds after all data is received before sending any commands to the load. \*RST sets the voltage protection level to 600, Current protection to 600 (or the total current of the system when slaves are connected), and power protection to 5000 (or 600 multiplied by the total current of system when slaves are connected). \*RST also resets damping to the factory default levels of 5 and 3, sets SYST:COMM:ECHO to on (see PAR. B.84), and sets SYST:REPLY to off; it does not affect any set points.

## B.4 DIAGnostic:TREE:DISPlay COMMAND

## DIAG:TREE:DISP

Syntax: Short Form: DIAG:TREE:DISP Long Form: DIAGnostic:TREE:DISPlay

Description: **Produces text file showing the SCPI command set accessible to the user.** The text file is arranged in columns and can be imported into a spreadsheet application such as Excel for easy viewing. The column separator is determined by DIAG:TREE:SEP command

### B.5 DIAGnostic:TREE:SEParator COMMAND

## DIAG:TREE:SEP

Syntax: Short Form: DIAG:TREE:SEP <NR1> Long Form: DIAGnostic:TREE:SEParator <NR1>  
where <NR1> defines the column separator

Description: **Defines the column separator used when producing a text file of the command set using DIAG:TREE:DISP command.**

### B.6 DIAGnostic:TREE:SEParator? QUERY

## DIAG:TREE:SEP?

Syntax: Short Form: DIAG:TREE:SEP? Long Form: DIAGnostic:TREE:SEParator?  
Returns <NR1> defines the column separator

Description: **Returns the number corresponding to the selected column separator when producing a text file of the command set using DIAG:TREE:DISP command.**

### B.7 LOCK COMMAND

## LOCK

Syntax: Short Form: LOCK <lock state> Long Form: LOCK <lock state>  
where <lock state> = OFF, EMERgency or LOCKed

Description: **Controls functionality of front panel controls.** When set to OFF, all front panel controls are fully functional. When set to EMER, the front panel LOAD switch can only turn the load to the off state; all other front panel controls except for the POWER switch are disabled. When set to LOCK, all front panel controls except for the POWER switch are disabled.

### B.8 LOCK? QUERY

## LOCK?

Syntax: Short Form: LOCK? Long Form: LOCK?  
Returns: <lock state> = OFF, EMERgency or LOCKed

Description: **Indicates state of front panel controls.**

### B.9 [SOURce:]INPut[:STATe] COMMAND

## INP

Syntax: Short Form: [SOUR:]INP[:STAT] <bool> Long Form: [SOURce:]INPut[:STATe] <bool>  
where <bool> = 0 or OFF (load disengaged) or 1 or ON (load engaged)

Description: **Used to engage or disengage the load from the UUT.** When set to 1 the load engages at the programmed mode and corresponding setpoint value; when set to 0 the load disengages.

### B.10 [SOURce:]INPut[:STATe]? QUERY

## INP?

Syntax: Short Form: [SOUR:]INP[:STAT]? Long Form: [SOURce:]INPut[:STATe]?  
Returns <bool> = 0 or OFF (load disengaged), 1 or ON (load engaged), or 1,DIS (load disabled)

Description: **Indicates whether load is engaged or disengaged from the UUT.** When set to 1 the load is engaged, when set to 0 the load is disengaged. When INP? returns 1,DIS it indicates that the output has been disabled because input voltage was lost while the load was engaged and input voltage is below the cutoff voltage established by INP:CUT:VOLT.

### B.11 [SOURce:]INPut:CUToff:TIME COMMAND

## INP:CUT:TIME

Syntax: Short Form: [SOURce:]INP:CUT:TIME <value>  
Long Form: [SOURce:]INPut:CUToff:TIME <value>  
where <NR2> = .0000 to 9999.000 (seconds)

Description: **Establishes the amount of time to wait for input voltage to recover after input is in Disabled state. When set to 0, input ramp will be disabled.** Input disabled state occurs when input voltage falls below value established by INP:CUT:VOLT while load was engaged (see PAR. B.13). While input is disabled, the LOAD indicator blinks green/amber and INP? returns 1,DIS. If input is still disabled after time established by INP:CUT:TIM, the input state is set to off: INP? returns 0 and the LOAD indicator shows steady green. This command is only effective if INP:CUT:VOLT command is implemented. See PAR. 3.16 and Figure 3-7 for details about how this command functions.

## B.12 [SOURce:]INPut:CUToff:TIME? QUERY

## INP:CUT:TIME?

Syntax: Short Form: [SOURce:]INP:CUT:TIME? Long Form: [SOURce:]INPut:CUToff:TIME?  
Returns <NR2> = .0000 to 9999.000 (seconds)

Description: **Returns time (in milliseconds) established by INP:CUT:TIME (PAR. B.11).** This is the time to wait before changing input from disabled to off.

## B.13 [SOURce:]INPut:CUToff:VOLTage COMMAND

## INP:CUT:VOLT

Syntax: Short Form: [SOURce:]INP:CUT:VOLT <value>  
Long Form: [SOURce:]INPut:CUToff:VOLTage <value>  
where <NR2> = minimum input voltage (Volts)

Description: **Establishes a minimum input voltage required for engaging the load.** When input voltage drops below minimum input voltage, the input is disabled (set to 0 for current and conductance, set to maximum for voltage and resistance), the LOAD indicator begins blinking green/amber and INP? returns 1,DIS (disabled). If the voltage increases above minimum input voltage (B, Figure 3-7) while the input is disabled, the load is engaged, the input is enabled and the load returns to the previous setpoint. The LOAD indicator changes to steady amber to indicate the load is engaged and INP? returns 1 (on). See PAR. 3.16 and Figure 3-7 for details about how this command functions.

## B.14 [SOURce:]INPut:CUToff:VOLT? QUERY

## INP:CUT:VOLT?

Syntax: Short Form: [SOURce:]INP:CUT:VOLT? Long Form: [SOURce:]INPut:CUToff:VOLTage?  
Returns <NR2> = minimum input voltage (Volts)

Description: **Returns the value of minimum input voltage set by INP:CUT:VOLT (see PAR. B.13).**

## B.15 INPut:RAMP COMMAND

## INP:RAMP

Syntax: Short Form: INP:RAMP <NR1> Long Form: INPut:RAMP <NR1>  
where <NR1> = input ramp time (0 to 2,000 msec)

Description: **Establishes a ramp to reach operating mode setpoint after engaging the load.** When the load is engaged, this command establishes the time it takes to attain the operating mode setpoint value. For current and conductance modes, the ramp starts at zero and increases in even steps over the duration established by <time> until the setpoint is reached. For voltage and resistance modes the ramp starts at maximum and decreases to the setpoint value. This command does not operate in Power mode. Units shipped from the factory are set to the recommended minimum of 20 milliseconds.

If the input ramp time is set to a number between 1 and 10,000, the ramp occurs when either a) the LOAD switch is pressed to engage the load or b) when input voltage is lost, then rises above the cutoff point while INP:CUT:VOLT (see PAR. B.13) is active. To turn off this ramp, send INP:RAMP 0. Setting INP:CUT:VOLT to any value will disable the output and reduce overshoot at the start of the ramp.

This command operates in conjunction with SYST:RAMP (see PAR. B.106) which establishes a ramp that is effective when the output changes state. If SYST:RAMP is in use, the ramp introduced by INP:RAMP will be the larger of the times set by INP:RAMP and SYST:RAMP.

Figure 3-7 shows the timing for INP:RAMP. The initial conditions are: the load is disengaged, LOAD indicator shows green, input voltage is present, and the output is 0 for current or conductance, maximum for voltage or resistance. Sending INP? at this point returns 0, indicating the load is disengaged. When the LOAD switch is pressed or INP:ON is received, the LOAD indicator changes to amber, the load is engaged and the input ramps to the setpoint value within the time established by INP:RAMP (A, Figure 3-7). Sending INP? returns 1 (on).



If input voltage from the UUT (unit under test) is subsequently lost, the output is shorted (all FET's are on). When input voltage recovers, the input changes from a short to the proper setpoint in a time determined by the SYST:DAMP command, the source capabilities of the UUT and the cabling between the load and the UUT. To maintain a ramp and eliminate any overshoot, ensure that INP:CUT:VOLT is set to some value to enable the ramp on this condition. Pressing the LOAD switch disengages the load; the LOAD indicator turns green and sending INP? returns 0 (disengaged).

See PAR. 3.15 and Figure 3-7 for details about how this command functions.

#### B.16 INPut:RAMP? QUERY

### INP:RAMP?

Syntax: Short Form: INP:RAMP? Long Form: INPut:RAMP?  
Returns <NR1> = time (0 to 2,000 msec)

Description: **Returns the ramp time established by INP:RAMP.** This is the time needed to reach setpoint value after the load is engaged.

#### B.17 [SOURce:]INPut:PROTection:CLEar COMMAND

### INP:PROT:CLE

Syntax: Short Form: [SOUR:]INP:PROT:CLE Long Form: [SOURce:]INPut:PROTection:CLEar

Description: **Resets protection from overcurrent, overpower, etc.**

#### B.18 [SOURce:]INPut:PROTection:SHORt[:STATe] COMMAND

### INP:PROT:SHOR

Syntax: Short Form: [SOUR:]INP:PROT:SHOR[:STAT]  
Long Form: [SOURce:]INPut:PROTection:SHORt[:STATe]

Description: **Applies maximum drive to FETs, effectively shorting the input.**

#### B.19 [SOURce:]OUTPut[:STATe] COMMAND

### OUTP

Syntax: Short Form: [SOUR:]OUTP[:STAT] <bool> Long Form: [SOURce:]OUTPut[:STATe] <bool>  
where <bool> = 0 or OFF (load disengaged) or 1 or ON (load engaged)

Description: **Used to engage or disengage the load from the UUT.** When set to 1 the load engages, when set to 0 the load disengages.

#### B.20 [SOURce:]OUTPut[:STATe]? QUERY

### OUTP?

Syntax: Short Form: [SOUR:]OUTP[:STAT]? Long Form: [SOURce:]OUTPut[:STATe]?  
Returns <bool> = 0 or OFF (load disengaged) or 1 or ON (load engaged)

Description: **Indicates whether load is engaged or disengaged from the UUT.** When set to 1 the load is engaged, when set to 0 the load is disengaged.

#### B.21 [SOURce:]OUTPut:PROTection:CLEar COMMAND

### OUTP:PROT:CLE

Syntax: Short Form: [SOUR:]OUTP:PROT:CLE Long Form: [SOURce:]OUTPut:PROTection:CLEar

Description: **Resets protection from overcurrent, overpower, etc.**

#### B.22 [SOURce:]OUTPut:PROTection:SHORt[:STATe] COMMAND

### OUTP:PROT:SHOR

Syntax: Short Form: [SOUR:]INP:PROT:SHOR[:STAT]  
Long Form: [SOURce:]INPut:PROTection:SHORt[:STATe]

Description: **Applies maximum drive to FETs, effectively shorting the output.**

**B.23 [SOURCE:]MEASURE:ALL? QUERY****MEAS:ALL?**

Syntax: Short Form: [SOURCE:]MEAS:ALL? Long Form: [SOURCE:]MEASURE:ALL?  
Returns: Measured values in the form 0.000 KW, 0.000 Amps, 0.000 Volts.

Description: Measures output power (Kilowatts), current (Amps), and voltage (Volts). Unit of measurement included in the reply.

**B.24 [SOURCE:]MEASURE:ALL2? QUERY****MEAS:ALL2?**

Syntax: Short Form: [SOURCE:]MEAS:ALL2? Long Form: [SOURCE:]MEASURE:ALL2?  
Returns: Measured values in the form 0.000 0.000 0.000 (Kilowatts Amps Volts).

Description: Measures output power (Kilowatts), current (Amps), and voltage (Volts). Unit of measurement is omitted from the reply.

**B.25 [SOURCE:]MEASURE[:SCALAR]:CURRENT[:DC]? QUERY****MEAS:CURR?**

Syntax: Short Form: [SOURCE:]MEAS[:SCALAR]:CURR[:DC]?  
Long Form: [SOURCE:]MEASURE[:SCALAR]:CURRENT[:DC]?  
Returns: Measured values.

Description: **Measures current.** Measured value returned as XXX Amps, where XXX is decimal data representing measured current.

**B.26 [SOURCE:]MEASURE[:SCALAR]:POWER[:DC]? QUERY****MEAS:POW?**

Syntax: Short Form: [SOURCE:]MEAS[:SCALAR]:POW[:DC]?  
Long Form: [SOURCE:]MEASURE[:SCALAR]:POWER[:DC]?  
Returns: Measured values in the form 0.000 Kilowatts

Description: **Measures power.** Measured value returned as XXX Kilowatts, where XXX represents measured power.

**B.27 [SOURCE:]MEASURE[:SCALAR]:VOLTAGE[:DC]? QUERY****MEAS:VOLT?**

Syntax: Short Form: [SOURCE:]MEAS[:SCALAR]:VOLT[:DC]?  
Long Form: [SOURCE:]MEASURE[:SCALAR]:VOLTAGE[:DC]?  
Returns: Measured values in the form XXX Volts

Description: **Measures voltage.** Measured value returned as XXX Volts, where XXX is decimal data representing measured voltage.

**B.28 [SOURCE:]CONDUCTANCE[:LEVEL][:IMMEDIATE][:AMPLITUDE] COMMAND****COND**

Syntax: Short Form:[SOURCE:]COND[:LEV][:IMM][:AMP] <NR2>  
Long Form: [SOURCE:]CONDUCTANCE[:LEVEL][:IMMEDIATE][:AMPLITUDE] <NR2>  
Where <NR2> = conductance setpoint in Siemens

Description: **Establishes conductance setpoint.** Conductance setpoint affects the load only when the load is in Conductance mode of operation. Conductance setpoint is stored in non-volatile memory; value is restored upon power-up.

**B.29 [SOURCE:]CONDUCTANCE[:LEVEL][:IMMEDIATE][:AMPLITUDE]? QUERY****COND?**

Syntax: Short Form:[SOURCE:]COND[:LEV][:IMM][:AMP]?  
Long Form: [SOURCE:]CONDUCTANCE[:LEVEL][:IMMEDIATE][:AMPLITUDE]?  
Returns <NR2> = conductance setpoint in Siemens

Description: **Indicates conductance setpoint.**

**B.30 [SOURCE:]CONDuctance:TRANSient COMMAND****COND:TRAN**

Syntax: Short Form: [SOUR:]COND:TRAN <value>,<time>,<period>,<count>  
 Long Form: [SOURCE:]CONDuctance:TRANSient <value>,<time>,<period>,<count>  
 Where:  
 <value> = <NR2> = the maximum conductance value of the transient (Siemens)  
 <time> = <NR2> = time (Seconds) from start to end of transient (0.0005 Second minimum)  
 <count> = <NR1> = number of times transient is to be repeated (default = 1, maximum = 65,000)  
 <period> (optional) = <NR2> = total time (Seconds) of repeating pulse train (must be at least 0.0005 greater than transient <time>)

Description: **Configures a transient conductance pulse that is initiated by SYST:MODE:TRAN (see PAR. B.100).** See PAR. B.106 for details on using both Transient and Ramp commands at the same time. Figure B-1 on page B-18 shows transient and ramp timing.

**B.31 [SOURCE:]CONDuctance:TRANSient? QUERY****COND:TRAN?**

Syntax: Short Form: [SOUR:]COND:TRAN?  
 Long Form: [SOURCE:]CONDuctance:TRANSient?  
 Returns: <value>,<time>,<period>,<count> (see PAR. B.30 for definitions).

Description: **Indicates Conductance Transient parameters established by COND:TRAN command (PAR. B.30).**

**B.32 [SOURCE:]CURRent[:LEVel][:IMMEDIATE][:AMPLitude] COMMAND****CURR**

Syntax: Short Form: [SOUR:]CURR[:LEV][:IMM][:AMP] <NR2>  
 Long Form: [SOURCE:]CURRent[:LEVel][:IMMEDIATE][:AMPLitude] <NR2>  
 Where <NR2> = current setpoint

Description: **Current Setting.** The current setpoint affects the load only when the load is in Current mode of operation. Current setpoint is stored in non-volatile memory; value is restored upon power-up.

**B.33 [SOURCE:]CURRent[:LEVel][:IMMEDIATE][:AMPLitude]? QUERY****CURR?**

Syntax: Short Form: [SOUR:]CURR[:LEV][:IMM][:AMP]?  
 Long Form: [SOURCE:]CURRent[:LEVel][:IMMEDIATE][:AMPLitude]?  
 Returns <NR2> = current setpoint

Description: **Indicates Current Setpoint.**

**B.34 [SOURCE:]CURRent:PROTection[:LEVel] COMMAND****CURR:PROT**

Syntax: Short Form: [SOUR:]CURR:PROT[:LEV] <NR2>  
 Long Form: [SOURCE:]CURRent:PROTection[:LEVel] <NR2>  
 where: <NR2> = current protection setpoint

Description: **Establishes current protection setpoint.** Current protection setpoint is stored in non-volatile memory; value is restored upon power-up. This is a user-defined value which, if exceeded during operation, causes a FAULT condition, forcing the load to disengage.

**B.35 [SOURCE:]CURRent:PROTection[:LEVel]? QUERY****CURR:PROT?**

Syntax: Short Form: [SOUR:]CURR:PROT[:LEV]?  
 Long Form: [SOURCE:]CURRent:PROTection[:LEVel]?  
 Returns: <NR2> = current protection setpoint

Description: **Indicates current protection setpoint.**

**B.36 [SOURCE:]CURRENT:PROTECTION:STATE COMMAND****CURR:PROT:STAT 0**

Syntax: Short Form: [SOURCE:]CURRENT:PROT:STAT 0  
 Long Form: [SOURCE:]CURRENT:PROTECTION:STATE 0

Description: **Clears current protection level error.**

**B.37 [SOURCE:]CURRENT:PROTECTION:STATE? QUERY****CURR:PROT:STAT?**

Syntax: Short Form: [SOURCE:]CURRENT:PROT:STAT?  
 Long Form: [SOURCE:]CURRENT:PROTECTION:STATE?  
 Returns: <bool> = 1 (current protection error occurred)  
 0 (current protection error has not occurred)

Description: **Indicates whether a current protection error has occurred (1) or not (0).**

**B.38 [SOURCE:]CURRENT:TRANSIENT COMMAND****CURR:TRAN**

Syntax: Short Form: [SOURCE:]CURRENT:TRAN <value>,<time>,<period>,<count>  
 Long Form: [SOURCE:]CURRENT:TRANSIENT <value>,<time>,<period>,<count>  
 Where:  
 <value> = <NR2> = the maximum current value of the transient (Amperes)  
 <time> = <NR2> = time (Seconds) from start to end of transient (0.0005 Second minimum)  
 <count> = <NR1> = number of times transient is to be repeated (default = 1, maximum = 65,000)  
 <period> (optional) = <NR2> = total time (Seconds) of repeating pulse train (must be at least 0.0005 greater than transient <time>)

Description: **Configures a transient current pulse that is initiated by SYST:MODE:TRAN (see PAR. B.100).** See PAR. B.106 for details on using both Transient and Ramp commands at the same time. Figure B-1 on page B-18 shows transient and ramp timing.

**B.39 [SOURCE:]CURRENT:TRANSIENT? QUERY****CURR:TRAN?**

Syntax: Short Form: [SOURCE:]CURRENT:TRAN?  
 Long Form: [SOURCE:]CURRENT:TRANSIENT?  
 Returns: <value>,<time>,<period>,<count> (See PAR. B.38 for definitions.)

Description: **Returns the transient current pulse parameters established by CURR:TRAN (see PAR. B.38).**

**B.40 [SOURCE:]MODE COMMAND****MODE**

Syntax: Short Form: [SOURCE:]MODE <txt> Long Form: [SOURCE:]MODE <txt>  
 where: <txt> = CURRENT, POWER, VOLTAGE, RESISTANCE, CONDUCTANCE, SHORT or OFF.

Description: **Sets operating mode:** When the operating mode is changed, the input is set to off. Send INPUT ON to apply the new mode setting to the load.

**B.41 [SOURCE:]MODE? QUERY****MODE?**

Syntax: Short Form: [SOURCE:]MODE? Long Form: [SOURCE:]MODE?  
 Returns: <txt> = CURR, POW, VOLT, RES, COND, SHORT or OFF.

Description: **Indicates operating mode.**

**B.42 [SOURCE:]POWER[:LEVEL][:IMMEDIATE][:AMPLITUDE] COMMAND****POW**

Syntax: Short Form: [SOURCE:]POWER[:LEVEL][:IMMEDIATE][:AMPLITUDE] <NR2>  
 Long Form: [SOURCE:]POWER[:LEVEL][:IMMEDIATE][:AMPLITUDE] <NR2>  
 Where <NR2> = power setpoint

Description: **Establishes power setpoint.** The power setpoint only affects the load when the load is in Power mode of operation.

**B.43 [SOURCE:]POWER[:LEVel][:IMMEDIATE][:AMPLITUDE]? QUERY****POW?**

Syntax: Short Form: [SOUR:]POW[:LEV][:IMM][:AMP]?  
 Long Form: [SOURCE:]POWER[:LEVel][:IMMEDIATE][:AMPLITUDE]?  
 Returns <NR2> = power setpoint

Description: **Indicates power setpoint.**

**B.44 [SOURCE:]POWER:PROTECTION COMMAND****POW:PROT**

Syntax: Short Form: [SOUR:]POW:PROT <NR2> Long Form: [SOURCE:]POWER:PROTECTION <NR2>  
 where <NR2> = power protection setpoint

Description: **Selects power protection setpoint.** This is a user-defined value which, if exceeded during operation, causes a FAULT condition, forcing the load to disengage.

**B.45 [SOURCE:]POWER:PROTECTION? QUERY****POW:PROT?**

Syntax: Short Form: [SOUR:]POW:PROT? Long Form: [SOURCE:]POWER:PROTECTION?  
 Returns <NR2> = power protection setpoint

Description: **Indicates power protection setpoint.**

**B.46 [SOURCE:]POWER:PROTECTION:STATE[:LEVel] COMMAND****POW:PROT:STAT 0**

Syntax: Short Form: [SOUR:]POW:PROT:STAT[:LEV] 0  
 Long Form: [SOURCE:]POWER:PROTECTION:STATE[:LEVel] 0

Description: **Clears power protection error.**

**B.47 [SOURCE:]POWER:PROTECTION:STATE[:LEVel]? QUERY****POW:PROT:STAT?**

Syntax: Short Form: [SOUR:]POW:PROT:STAT[:LEV]?  
 Long Form: [SOURCE:]POWER:PROTECTION:STATE[:LEVel]?  
 where: <bool> = 1 (power protection error occurred)  
 0 (power protection error has not occurred)

Description: **Indicates whether a power protection error has occurred (1) or not (0).**

**B.48 [SOURCE:]RESISTANCE[:LEVel][:IMMEDIATE][:AMPLITUDE] COMMAND****RES**

Syntax: Short Form: [SOUR:]RES[:LEV][:IMM][:AMP] <NR2>  
 Long Form: [SOURCE:]RESISTANCE[:LEVel][:IMMEDIATE][:AMPLITUDE] <NR2>  
 Where: <NR2> = resistance setpoint

Description: **Establishes resistance setpoint.** The resistance setpoint only affects the load when the load is in Resistance mode of operation. Resistance setpoint is stored in non-volatile memory; value is restored upon power-up.

**B.49 [SOURCE:]RESISTANCE[:LEVel][:IMMEDIATE][:AMPLITUDE]? QUERY****RES?**

Syntax: Short Form: [SOUR:]RES[:LEV][:IMM][:AMP]?  
 Long Form: [SOURCE:]RESISTANCE[:LEVel][:IMMEDIATE][:AMPLITUDE]?  
 Returns: <NR2> = resistance setpoint

Description: **Indicates resistance setpoint.**

## B.50 [SOURce:]RESistance:TRANSient COMMAND

## RES:TRAN

Syntax: Short Form: [SOUR:]RES:TRAN <value>,<time>,<period>,<count>  
Long Form: [SOURce:]RESistance:TRANSient <value>,<time>,<period>,<count>  
Where:  
<value> = <NR2> = the maximum resistance value of the transient (Ohms)  
<time> = <NR2> = time (Seconds) from start to end of transient (0.0005 Second minimum)  
<count> = <NR1> = number of times transient is to be repeated (default = 1, maximum = 65,000)  
<period> (optional) = <NR2> = total time (Seconds) of repeating pulse train (must be at least 0.0005 greater than transient <time>)

Description: **Configures a transient resistance pulse that is initiated by SYST:MODE:TRAN (see PAR. B.100).**  
See PAR. B.106 for details on using both Transient and Ramp commands at the same time. Figure B-1 on page B-18 shows transient and ramp timing.

## B.51 [SOURce:]RESistance:TRANSient? QUERY

## RES:TRAN?

Syntax: Short Form: [SOUR:]RES:TRAN?  
Long Form: [SOURce:]RESistance:TRANSient?  
Returns: <value>,<time>,<period>,<count> (see PAR. B.50 for definitions.)

Description: **Returns the transient resistance pulse parameters established by RES:TRAN (see PAR. B.50).**

## B.52 [SOURce:]VOLTage[:LEVel][:IMMEDIATE][:AMPLitude] COMMAND

## VOLT

Syntax: Short Form: [SOUR:]VOLT[:LEV][:IMM][:AMP] <NR2>  
Long Form: [SOURce:]VOLTage[:LEVel][:IMMEDIATE][:AMPLitude] <NR2>  
where: <NR2> = voltage setpoint

Description: **Establishes voltage setpoint.** The voltage setpoint only affects the load when the load is in Voltage mode of operation. Voltage setpoint is stored in non-volatile memory; value is restored upon power-up.

## B.53 [SOURce:]VOLTage[:LEVel][:IMMEDIATE][:AMPLitude]? QUERY

## VOLT?

Syntax: Short Form: [SOUR:]VOLT[:LEV][:IMM][:AMP]?  
Long Form: [SOURce:]VOLTage[:LEVel][:IMMEDIATE][:AMPLitude]?  
Returns: <NR2> = voltage setpoint

Description: **Indicates voltage setpoint.**

## B.54 [SOURce:]VOLTage:PROTection:OVER COMMAND

## VOLT:PROT:OVER

Syntax: Short Form: [SOUR:]VOLT:PROT:OVER <NR2>  
Long Form: [SOURce:]VOLTage:PROTection:OVER <NR2>  
where <NR2> = overvoltage protection limit

Description: **Sets overvoltage protection limit.** Overvoltage protection setpoint is stored in non-volatile memory; value is restored upon power-up.

## B.55 [SOURce:]VOLTage:PROTection:OVER? QUERY

## VOLT:PROT:OVER?

Syntax: Short Form: [SOUR:]VOLT:PROT:OVER?  
Long Form: [SOURce:]VOLTage:PROTection:OVER?  
Returns <NR2> = overvoltage protection limit

Description: **Indicates overvoltage protection limit.**

## B.56 [SOURce:]VOLTage:PROTection:OVER:STATe[:LEVel] COMMAND

## VOLT:PROT:OVER:STAT 0

Syntax: Short Form: [SOUR:]VOLT:PROT:OVER:STAT[:LEV] 0  
Long Form: [SOURce:]VOLTage:PROTection:OVER:STATe[:LEVel] 0

Description: **Clears overvoltage protection error.**

**B.57 [SOURCE:]VOLTage:PROTection:OVER:STAT[:LEVel]? COMMAND** **VOLT:PROT:OVER:STAT?**

Syntax: Short Form: [SOUR:]VOLT:PROT:OVER:STAT[:LEV]  
Long Form: [SOURCE:]VOLTage:PROTection:OVER:STATe[:LEVel]  
where <bool> = 1 (overvoltage protection error occurred)  
0 (overvoltage protection error has not occurred)

Description: **Indicates whether an overvoltage protection has occurred (1) or not (0).**

**B.58 [SOURCE:]VOLTage:PROTection:UNDer COMMAND** **VOLT:PROT:UND**

Syntax: Short Form: [SOUR:]VOLT:PROT:UND <NR2>  
Long Form: [SOURCE:]VOLTage:PROTection:UNDer <NR2>  
where <NR2> = undervoltage protection limit

Description: **Sets undervoltage protection limit.** Undervoltage protection setpoint is stored in non-volatile memory; value is restored upon power-up.

**B.59 [SOURCE:]VOLTage:PROTection:UNDer? QUERY** **VOLT:PROT:UND?**

Syntax: Short Form: [SOUR:]VOLT:PROT:UND? Long Form: [SOURCE:]VOLTage:PROTection:UNDer?  
Returns: <NR2> = undervoltage protection limit

Description: **Indicates undervoltage protection limit.**

**B.60 [SOURCE:]VOLTage:PROTection:UNDer:STATE[:LEVel] COMMAND** **VOLT:PROT:UND:STAT 0**

Syntax: Short Form: [SOUR:]VOLT:PROT:UND:STAT[:LEV] 0  
Long Form: [SOURCE:]VOLTage:PROTection:UNDer:STATe[:LEVel] 0

Description: **Clears undervoltage protection error.** This error occurs when input voltage is less than VOLT:PROT:UND level.

**B.61 [SOURCE:]VOLTage:PROTection:UNDer:STATE[:LEVel]? QUERY** **VOLT:PROT:UND:STAT?**

Syntax: Short Form: [SOUR:]VOLT:PROT:UND:STAT[:LEV]?  
Long Form: [SOURCE:]VOLTage:PROTection:UNDer:STATe[:LEVel]?  
where <bool> = 1 (undervoltage protection error occurred)  
0 (undervoltage protection error has not occurred)

Description: **Indicates whether an undervoltage protection error has occurred (1) or not (0).**

**B.62 [SOURCE:]VOLTage:TRANsient COMMAND** **VOLT:TRAN**

Syntax: Short Form: [SOUR:]VOLT:TRAN <value>,<time>,<period>,<count>  
Long Form: [SOURCE:]VOLTage:TRANsient <value>,<time>,<period>,<count>  
Where:  
<value> =<NR2> = the maximum voltage value of the transient (Volts)  
<time> =<NR2> = time (Seconds) from start to end of transient (0.0005 Second minimum)  
<count> =<NR1> = number of times transient is to be repeated (default = 1, maximum = 65,000)  
<period> (optional) =<NR2> = total time (Seconds) of repeating pulse train (must be at least 0.0005 greater than transient <time>)

Description: **Configures a transient voltage pulse that is initiated by SYST:MODE:TRAN (see PAR. B.100).**

### B.63 [SOURce:]VOLTage:TRANsient? QUERY

## VOLT:TRAN?

Syntax: Short Form: [SOUR:]VOLT:TRAN?  
 Long Form: [SOURce:]VOLTage:TRANsient?  
 Returns: <value>,<time>,<count>,<period> (optional) (See PAR. B.62) for definitions.)

Description: **Returns the transient voltage pulse parameters established by VOLT:TRAN (PAR. B.62).**

### B.64 STATus:CHANnel[:EVENT]? QUERY

## STAT:CHAN?

Syntax: Short Form: STAT:CHAN[:EVEN]? Long Form: STATus:CHANnel[:EVENT]?  
 Returns: <16 bits> = the value of the Channel event register.

Description: **Returns value of Channel event register.** Each PFM within a chassis has three Channel registers associated with it. Bits in the Event register are set whenever the associated condition occurs, and are cleared only upon an explicit command, thus latching any conditions that occur. See Table B-2 for bit assignments.

**TABLE B-2. CHANNEL STATUS CONDITION, ENABLE, AND EVENT REGISTER BITS**

CONDITION	NU	PS	OV	NU	OT	OP	NU	OC	VF
BIT	14-15	13	12	5 - 11	4	3	2	1	0
VALUE	16384-32768	8192	4096	32-2048	16	8	4	2	1

NU - NOT USED  
 OC - OVERCURRENT  
 OP - OVERPOWER  
 OT - OVERTEMPERATURE  
 OV - OVERVOLTAGE  
 PS - PROTECTION SHUTDOWN  
 VF - VOLTAGE FAULT

### B.65 STATus:CHANnel:CONDition COMMAND

## STAT:CHAN:COND

Syntax: Short Form: STAT:CHAN:COND 0 Long Form: STATus:CHANnel:CONDition 0

Description: **Resets the Channel Enable Register bits to zero.**

### B.66 STATus:CHANnel:CONDition? QUERY

## STAT:CHAN:COND?

Syntax: Short Form: STAT:CHAN:COND? Long Form: STATus:CHANnel:CONDition?  
 Returns: <16 bits> = the value of the Channel condition register.

Description: **Returns the value of the Channel Condition Register.** Each PFM within a chassis has three Channel registers associated with it. The Condition register reflects the instantaneous state of that PFM. Bits in the Event register are set whenever the associated condition occurs, and are cleared only upon an STAT:CHAN:COND 0 command, thus latching any conditions that occur. See Table B-2 for bit assignments.

### B.67 STATus:CHANnel:ENABLE COMMAND

## STAT:CHAN:ENAB

Syntax: Short Form: STAT:CHAN:ENAB <NR1> Long Form: STATus:CHANnel:ENABLE <NR1>  
 Where <NR1> = 16 bits = the value of the Channel enable register.

Description: **Sets the Channel Enable Register to determine which bits are allowed to set the channel event register.** Each PFM within a chassis has three Channel registers associated with it. The Enable register selects which of the latched bits in the Event register can propagate to higher-level indicators. See Table B-2 for bit assignments.

### B.68 STATus:CHANnel:ENABLE? QUERY

## STAT:CHAN:ENAB?

Syntax: Short Form: STAT:CHAN:ENAB? Long Form: STATus:CHANnel:ENABLE?  
 Returns: <16 bits> = the value of the Channel enable register.

Description: **Returns the value of the Channel Enable Register.** See Table B-2 for bit assignments.



**B.69 STATus:CSUMmary[:EVENT]? QUERY**

**STAT:CSUM?**

Syntax: Short Form: STAT:CSUM[:EVENT]? Long Form: STATus:CSUMmary[:EVENT]?  
Returns: <16 bits> = the value of the Channel summary register.

Description: **Returns the value of the Channel Summary Register.** The Channel Summary Group contains an Event and Enable register which sums the

**TABLE B-3. CHANNEL SUMMARY ENABLE AND EVENT REGISTER BITS**

CONDITION	NU	SL14	SL13	SL12	SL11	SL10	SL9	SL8	SL7	SL6	SL5	SL4	SL3	SL2	SL1	MSTR
BIT	15	14	13	12	11	10	9	8	7	6	5	4	3	2	1	0
VALUE	32768	16384	8192	4096	2048	1024	512	256	128	64	32	16	8	4	2	1

MSTR MASTER  
NU NOT USED  
SL1 SLAVE 1  
through  
SL14 SLAVE 14

**B.70 STATus:CSUMmary:ENABle COMMAND**

**STAT:CSUM:ENAB**

Syntax: Short Form: STAT:CSUM:ENAB <NR1> Long Form: STATus:CSUMmary:ENABle <NR1>  
Where: <NR1> = 16 bits = the value of the Channel summary enable register.

Description: **Sets the value of the Channel Summary Enable Register to determine which bits are allowed to set the Channel Summary Register.**

**B.71 STATus:CSUMmary:ENABle? QUERY**

**STAT:CSUM:ENAB?**

Syntax: Short Form: STAT:CSUM:ENAB? Long Form: STATus:CSUMmary:ENABle?  
Returns: <16 bits> = the value of the Channel summary enable register.

Description: **Returns the value of the Channel Summary Enable Register.**

**B.72 STATus:OPERation[:EVENT]? QUERY**

**STAT:OPER?**

Syntax: Short Form: STAT:OPER[:EVENT]? Long Form: STATus:OPERation[:EVENT]?  
Return Value:

Description: **Indicates changes in conditions monitored by Operational Event Register.** Returns the value of the Operation Event register. The Operation Event register is a read-only register which holds (latches) all events that occur. Reading the Operation Event register clears it.

**TABLE B-4. OPERATION CONDITION REGISTER, OPERATION ENABLE REGISTER, AND OPERATION EVENT REGISTER BITS**

CONDITION	NU	PON	NU	CME	EXE	DDE	QYE	NU	NU
BIT	8 - 15	7	6	5	4	3	2	1	0
VALUE	256 - 32,768	128	64	32	16	8	4	2	1

CME COMMAND ERROR  
DDE DEVID DEPENDENT ERROR  
EXE EXECUTION ERROR  
NU - NOT USED  
PON POWER ON SINCE THIS BIT LAST READ  
QYE QUERY ERROR

**B.73 STATus:OPERation:CONDition? QUERY**

**STAT:OPER:COND?**

Syntax: Short Form: STAT:OPER:COND? Long Form: STATus:OPERation:CONDition?  
Return Value:

Description: **Returns the value of the Operation Condition Register.** The Operation Condition Register contains unlatched real-time information about the operating conditions of the load. Bit set to 1 = function enabled (active, true); bit reset to 0 = function disabled (inactive, false).

**B.74 STATUS:OPERation:ENABLE COMMAND****STAT:OPER:ENAB**

Syntax: Short Form: STAT:OPER:ENAB <int\_value>  
 Long Form: STATus:OPERation:ENABle <int\_value>

Description: **Sets Operation Enable Register.** The Operation Enable Register is a mask for enabling specific bits in the Operation Event Register which will cause the operation summary bit (bit 7) of the Status Byte register to be set. Bit set to 1 = function enabled (active, true); bit reset to 0 = function disabled (inactive, false). The operation summary bit is the logical OR of all the enabled bits in the Operation Event register.

**B.75 STATus:OPERation:ENABLE? QUERY****STAT:OPER:ENAB?**

Syntax: Short Form: STAT:OPER:ENAB? Long Form: STATus:OPERation:ENABLE?  
 Return Value: <int\_value>

Description: **Reads Operation Enable Register.** Returns value of Operation Enable Register bits. Bit set to 1 = function enabled (active, true); bit reset to 0 = function disabled (inactive, false).

**B.76 STATus:OPERation:NTRansition COMMAND****STAT:OPER:NTR**

Syntax: Short Form: STAT:OPER:NTR Long Form: STATus:OPERation:NTRansition

Description: **Negative transition enable register.**

**B.77 STATus:OPERation:PTRansition COMMAND****STAT:OPER:PTR**

Syntax: Short Form: STATus:OPERation:PTRansition Long Form: STATus:OPERation:PTRansition

Description: **Positive transition enable register.**

**B.78 STATus:QUEStionable[:EVENT]? QUERY****STAT:QUES?**

Syntax: Short Form: STAT:QUES[EVENT]? Long Form: STATus:QUEStionable[EVENT]?  
 Return Value: <NR1> =16 bits = actual Questionable register value

Description: **Indicates questionable events that occurred since previous STAT:QUES? query.** Returns the value of the Questionable Event register. The Questionable Event register is a read-only register which holds (latches) all events. Reading the Questionable Event register clears it.

**B.79 STATus:QUEStionable:CONDition? QUERY****STAT:QUES:COND?**

Syntax: Short Form: STAT:QUES:COND? Long Form: STATus:QUEStionable:CONDition?  
 Return Value: <NR1> =16 bits = actual Questionable condition register value

Description: **Returns the value of the Questionable Condition Register.** The Questionable Condition Register contains unlatched real-time information about questionable conditions of the electronic load. Bit set to 1 = condition (active, true); bit reset to 0 = condition (inactive, false). (See example, PAR. B.75.)

**B.80 STATus:QUEStionable:ENABLE COMMAND****STAT:QUES:ENAB**

Syntax: Short Form: STAT:QUES:ENAB <NR1> Long Form: STATus:QUEStionable:ENABLE <int\_value>

Description: **Programs Questionable Condition Enable Register.** The Questionable Condition Enable Register determines which conditions are allowed to set the Questionable Condition Register; it is a mask for enabling specific bits in the Questionable Event register that can cause the questionable summary bit (bit 3) of the Status Byte register to be set. The questionable summary bit is the logical OR of all the enabled bits in the Questionable Event register. Bit set to 1 = function enabled (active, true); bit reset to 0 = function disabled (inactive, false).

**B.81 STATus:QUEStionable:ENABle? QUERY****STAT:QUES:ENAB?**

Syntax: Short Form: STAT:QUES:ENAB? Long Form: STATus:QUEStionable:ENABle?  
Return Value: <NR1> =16 bits = actual Questionable enable register value

Description: **Reads Questionable Condition Enable Register.** Electronic load returns value of Questionable Condition Enable Register, indicating which conditions are being monitored. Bit set to 1 = function enabled (active, true); bit reset to 0 = function disabled (inactive, false).

**B.82 SYSTem:COMMunicate[:GPIB]:ADDRess COMMAND SYST:COMM[:GPIB]:ADDR**

Syntax: Short Form: SYST:COMM[:GPIB]:ADDR <NR1>  
Long Form: SYSTem:COMMunicate[:GPIB]:ADDRess <NR1>  
Where: <NR1> = numbers from 1 to 30 comprising the GPIB Address. Factory default GPIB address is 10.

Description: **Sets the GPIB Address to be used during communication over the GPIB interface.** After setting the address, the EL Load must be power cycled (turned off, then on) in order for the new GPIB address to take effect. Command is not valid from the GPIB interface.

**B.83 SYSTem:COMMunicate[:GPIB]:ADDRess? QUERY****SYST:COMM[:GPIB]:ADDR?**

Syntax: Short Form: SYST:COMM[:GPIB]:ADDR?  
Long Form: SYSTem:COMMunicate[:GPIB]:ADDRess?  
Returns: <NR1> = number from 1 to 30 comprising the GPIB Address

Description: **Returns the GPIB Address used during communication over the GPIB interface.** Command is not valid from the GPIB interface.

**B.84 SYSTem:COMMunicate:ECHO COMMAND****SYST:COMM:ECHO**

Syntax: Short Form: SYST:COMM:ECHO <bool> Long Form: SYSTem:COMMunicate:ECHO <bool>  
Where: 1 or ON turns on echo, 0 or off turns off echo

Description: **Causes the EL Load to return the parsed string to the user.** The parsed string may not be the complete string sent to the EL; the parsed string contains the short form mnemonic for the command. Factory default is SYST:COMM:ECHO off.

**B.85 SYSTem:COMMunicate:ECHO? QUERY****SYST:COMM:ECHO?**

Syntax: Short Form: SYST:COMM:ECHO? Long Form: SYSTem:COMMunicate:ECHO?  
Returns: 1 if echo is on, 0 if echo is off

Description: **Indicates whether echo is on or off.**

**B.86 SYSTem:COMMunicate:LAN:IPADdress COMMAND****SYST:COMM:LAN:IPAD**

Syntax: Short Form: SYST:COMM:LAN:IPAD <a.b.c.d>  
Long Form: SYSTem:COMMunicate:LAN:IPADdress <a.b.c.d>  
Where: <a, b, c, d> = numbers from 0 to 255 comprising the IP Address

Description: **Sets the IP address to be used during LAN communication.**

**B.87 SYSTem:COMMunicate:LAN:IPADdress? QUERY****SYST:COMM:LAN:IPAD?**

Syntax: Short Form: SYST:COMM:LAN:IPAD?  
Long Form: SYSTem:COMMunicate:LAN:IPADdress?  
Returns: <a.b.c.d> = numbers from 0 to 255 comprising the IP Address

Description: **Returns the IP Address used during LAN communication.**

**B.88 SYSTem:COMMunicate:LAN:MAC? QUERY****SYST:COMM:LAN:MAC?**

Syntax: Short Form: SYST:COMM:LAN:MAC?  
 Long Form: SYSTem:COMMunicate:LAN:MAC?  
 Returns: <nn> = hex MAC Address

Description: **Returns the hex MAC address of the unit if the ethernet (E suffix) option is installed; otherwise returns 00H.**

**B.89 SYSTem:COMMunicate:LAN:MODE COMMAND****SYST:COMM:LAN:MODE**

Syntax: Short Form: SYST:COMM:LAN:MODE [FIX | DCHP]  
 Long Form: SYSTem:COMMunicate:LAN:MODE [FIXed | DCHP]

Description: **Determines method used to obtain IP address for LAN communication.** SYST:COMM:LAN:MODE:FIX (default) configures the LAN port to use a static (fixed) IP address entered from the front panel. SYST:COMM:LAN:MODE DCHP configures the LAN port for the standard DHCP hub required interface; uses IP address in the 192.168.x.x range compatible with most default hub configurations.

**B.90 SYSTem:COMMunicate:LAN:MODE? QUERY****SYST:COMM:LAN:MODE?**

Syntax: Short Form: SYST:COMM:LAN:MODE?  
 Long Form: SYSTem:COMMunicate:LAN:MODE?  
 Returns: [FIXed | DCHP]

Description: **Returns IP Mode (method of finding the IP Address used during LAN communication); see PAR. B.89.**

**B.91 SYSTem:COMMunicate:LAN:SUBNetmask COMMAND****SYST:COMM:LAN:SUBN**

Syntax: Short Form: SYST:COMM:LAN:SUBN <a.b.c.d>  
 Long Form: SYSTem:COMMunicate:LAN:SUBNetmask <a.b.c.d>  
 Where: <a, b, c, d> = numbers from 0 to 255 comprising the Subnet Mask

Description: **Sets the Subnet Mask to be used during LAN communication.**

**B.92 SYSTem:COMMunicate:LAN:SUBNetmask? QUERY****SYST:COMM:LAN:SUBN?**

Syntax: Short Form: SYST:COMM:LAN:SUBN?  
 Long Form: SYSTem:COMMunicate:LAN:SUBNetmask?  
 Returns: <a.b.c.d> = numbers from 0 to 255 comprising the Subnet Mask

Description: **Returns the Subnet Mask used during LAN communication.**

**B.93 SYSTem:DAMPing COMMAND****SYST:DAMP**

Syntax: Short Form: SYST:DAMP x Long Form: SYSTem:DAMPing x  
 Where x = integer from 0 (minimum damping) to 7 (maximum damping) except units with firmware version suffix B2 and lower accept only 0 to 5(maximum)

Description: **Inserts capacitance required to damp oscillation.** Increased damping reduces the tendency for oscillation and reduces response time to high speed transients. Units shipped from the factory are shipped with SYST:DAMP set to 4. See PAR. 3.14 for an explanation of damping as well as a recommended procedure for adjusting damping.

**B.94 SYSTem:DAMPing? QUERY****SYST:DAMP?**

Syntax: Short Form: SYST:DAMP? Long Form: SYSTem:DAMPing?  
Returns x where x = integer from 0 (minimum damping) to 7 (maximum damping) (5 is maximum damping for units with firmware version suffix B2 or lower)

Description: **Inserts capacitance required to damp oscillation.** Factory default setting is 7 (default is 5 for units with firmware version suffix B2 or lower). See PAR. 3.14

**B.95 SYSTem:ERRor? QUERY****SYST:ERR?**

Syntax: Short Form: SYST:ERR? Long Form: SYSTem:ERRor?

Description: **Returns next entry from the error message queue.** Responds with the most recent error message in a queue of up to 10 possible messages and clears each error message as it is sent. Issuing \*CLS clears all error messages in the queue.

<u>Error Message</u>	<u>Code</u>
Command Error Generic	-100
Invalid Separator	-103
Illegal Parameter Value	-224
Invalid Unit Number	-241
Queue Overflow	-350
No Error	-0

**B.96 SYSTem:EXTernal COMMAND****SYST:EXT**

Syntax: Short Form: SYST:EXT <x> Long Form: SYSTem:EXTernal <x>  
where  
OFF = disable analog inputs  
ON = non-isolated (hazardous) external analog input enable  
ISOLated = isolated (SELV) external analog input enable

Description: **Enables or disables external analog programming.** OFF disables adjustment of the controlled parameter using an external voltage. ON enables the non-isolated (hazardous) external input from ± REF IN. ISOL enables the isolated (SELV) external input from pins 2 and 7 of the ANALOG CONTROL connector. Refer to PAR. 2.6.5 for details.

**B.97 SYSTem:EXTernal? QUERY****SYST:EXT?**

Syntax: Short Form: SYST:EXT? Long Form: SYSTem:EXTernal?  
Returns: OFF (disabled), ON (non-isolated external input enabled) or ISOL (isolated external input enabled).

Description: **Indicates whether external analog programming is enabled or disabled.** Refer to PAR. 2.6.5 for details.

**B.98 SYSTem:FAN COMMAND****SYST:FAN**

Syntax: Short Form: SYST:FAN <NR1> Long Form: SYSTem:FAN <NR1>  
Where <NR1> = integer, either 0 or 100

Description: **SYST:FAN 0 sets fan to off. SYST:FAN 100 sets fan to on.**

**B.99 SYSTem:FAN? QUERY****SYST:FAN?**

Syntax: Short Form: SYST:FAN? Long Form: SYSTem:FAN?  
Returns <NR1> = 0 or 100

Description: **Indicates fan status: 0 = off, 100 = on.**

## B.100 SYSTem:MODE COMMAND

## SYST:MODE

Syntax: Short Form: SYST:MODE <TRANS | FIX | EXT>  
 Long Form: SYSTem:MODE <TRANSient | FIXed | EXTernal>

Description: **Initiates a transient.** Sending SYST:MODE TRANS initiates a transient pulse. The operating MODE (PAR. B.40) determines the type of transient (voltage, current, conductance or resistance) and the transient parameters are determined by the corresponding transient command: for voltage see VOLT:TRAN, (PAR. B.62), for current see CURR:TRAN (PAR. B.38), for conductance see COND:TRAN (PAR. B.30) and for resistance see RES:TRAN (PAR. B.50).

Sending SYST:MODE FIX terminates SYST:MODE TRANS and disables analog programming (sets SYST:EXT (see PAR. B.96) to OFF).

Sending SYST:MODE EXT terminates SYST:MODE TRANS and enables analog programming (sets SYST:EXT (see PAR. B.96) to ON).

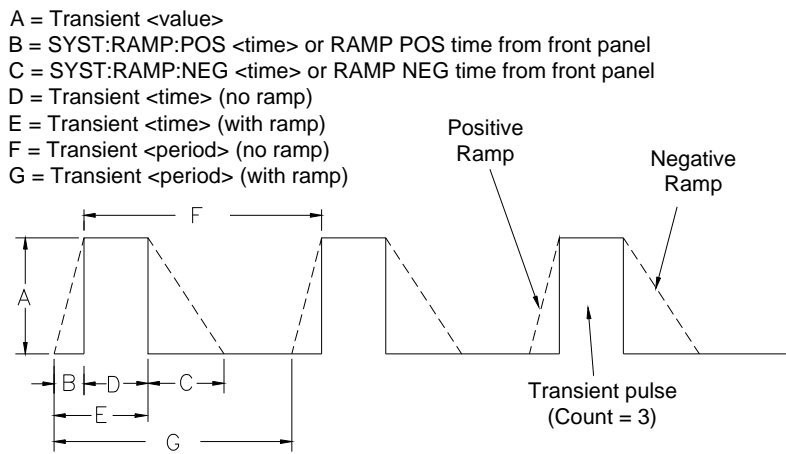

NOTE: TRANSIENT WILL NOT EXECUTE IF:  
 1.  $B > D$   
 2.  $E + C > G$

3043674

FIGURE B-1. RAMP AND TRANSIENT TIMING

## B.101 SYSTem:MODE? QUERY

## SYST:MODE?

Syntax: Short Form: SYST:MODE? Long Form: SYSTem:MODE?  
 Returns <TRAN | FIX | EXT>

Description: **Indicates SYSTem:MODE status.** Returns TRANS if transient is enabled, returns FIX if both transient and analog programming are disabled, and returns EXT if analog programming is enabled.

**B.102 SYSTem:PFModule:DAMPing COMMAND****SYST:PFM:DAMP**

Syntax: Short Form: SYST:PFM:DAMP <x> Long Form: SYSTem:PFModule:DAMPing <x>  
 Where <x> = integer from 0 (minimum damping) to 5 (maximum damping)

Description: **Establishes damping settings for Power FET Modules.** Increased damping decreases the loop's response time to transients. Factory default setting is 3.  
 Damping Settings: 0 - 1nF, 1 - 4.3nF, 2 - 11nF, 3 - 34nF, 4 - 101nF, 5 - 147.3nF. See PAR. 3.14 for details.

**B.103 SYSTem:PFModule:DAMPing? QUERY****SYST:PFM:DAMP?**

Syntax: Short Form: SYST:PFM:DAMP? Long Form: SYSTem:PFModule:DAMPing?  
 Returns <x> = integer from 0 (minimum damping) to 5 (maximum damping)

Description: **Indicating damping settings for Power FET Modules.** See PAR. 3.14 for details.

**B.104 SYSTem:PFModule:LIST? QUERY****SYST:PFM:LIST?**

Syntax: Short Form: SYST:PFM:LIST? Long Form: SYSTem:PFModule:LIST?

Description: **List Power FET Modules within chassis (see below for example).**

```
SYST:PFM:LIST?
KEPCO, EL 5K-200-600 01-18-2010,A999104,MCB #200 1.176 $ 2010/01/18 22:27:06 $
```

```
6 Power FET Modules Installed
```

Pos	Serial	Revision
0	292	1.39
1	293	
2	294	1.39
3	310	1.39
4	1200	1.39
5	296	

NOTE: PFM's with no revision are using Firmware Revisions below 1.35.

**B.105 SYSTem:PFModule:STATus? QUERY**

**SYST:PFM:STAT?**

Syntax: Short Form: SYST:PFM:STAT?

Long Form: SYSTem:PFModule:STATus?

Description: **Show FET channel temperature and fuse status (see below for example).**

```

SYST:PFM:STAT?
KEPCO, EL 5K-200-600 01-18-2010,A999104,MCB #200 1.176 $ 2010/01/18 22:27:06 $

0.000 100 26C 0.000 100 24C 0.020 100 24C 0.000 100 21C
0.000 100 26C 0.000 100 25C 0.000 100 23C 0.000 100 21C
0.000 100 26C 0.000 100 25C 0.000 100 24C 0.000 100 22C
0.000 100 27C 0.020 100 25C 0.000 100 24C 0.020 100 23C
0.000 100 27C 0.000 100 25C 0.000 100 24C 0.000 100 21C
0.000 100 27C 0.000 100 25C 0.000 100 24C 0.000 100 21C

      26 C      24 C      24 C      21 C
      26 C      25 C      23 C      21 C
      26 C      25 C      24 C      22 C
      27 C      25 C      24 C      23 C
      27 C      25 C      24 C      21 C
      27 C      25 C      24 C      21 C

```

Below is a response to SYST:PFM:STAT? for a 2 PFM Load when the load is drawing 52 Amperes. Note that these are not highly accurate current measurements but rather are intended to show system status such as the distribution of current (and therefore power) between the FETs. In the example below, the top row is the second set of FETs and the bottom row is the first row of FETs. The Currents are for FETs in each of the four positions as viewed from the front.

```

SYST:PFM:STAT?
KEPCO, EL 5K-200-600 01-18-2010,A999104,MCB #200 1.176 $ 2010/01/18 22:27:06 $

0.000 100 26C 0.000 100 24C 0.020 100 24C 0.000 100 21C
KEPCO, EL XK-VVV-AAA,12345,MCB #205 1.195 $ 2010/02/22 12:48:37 $

6.590 100 21C 6.590 100 20C 6.590 100 19C 6.615 100 19C
6.565 100 23C 6.565 100 21C 6.590 100 20C 6.590 100 19C

      21 C      20 C      19 C      19 C
      23 C      21 C      20 C      19 C

```

Below is an example showing illustrating a Fuse blows on the PFM.

```

KEPCO, EL 5K-200-600 01-18-2010,A999101,MCB #205 1.176 $ 2010/01/18
22:27:06 $

1.585 100 119C 1.535 100 117C 1.610 100 113C 1.585 100 97C
1.535 100 104C 1.585 100 114C 1.535 100 110C 1.610 100 104C
1.560 100 98C 1.585 100 106C 1.585 100 100C 1.585 100 101C
1.610 100 94C 1.560 100 93C 1.585 100 100C 1.610 255 91C
1.535 100 87C 1.535 100 82C 1.560 100 86C 1.585 100 82C
1.560 100 74C 1.535 100 76C 1.560 100 76C 1.535 100 71C

      119 C      117 C      113 C      97 C
      104 C      114 C      110 C      104 C
      98 C      106 C      100 C      101 C
      94 C      93 C      100 C      FUSE 91 C
      87 C      82 C      86 C      82 C
      74 C      76 C      76 C      71 C

```



## B.106 SYSTem:RAMP COMMAND

## SYST:RAMP

Syntax: Short Form: SYST:RAMP <time> Long Form: SYSTem:RAMP <time>  
Where <time> is ramp duration (Seconds) of both positive and negative ramps from 0.0001 to 10.000.

Description: **Establishes the time for unit to change states in both positive and negative directions.** See SYST:RAMP:POS (PAR. B.108) and SYST:RAMP:NEG (PAR. B.110) to set different ramp times for positive and negative directions.

Ramps work in all modes except power. The ramp consists of up to 4000 evenly spaced steps in times from 4.5 microseconds to 2.50 milliseconds (max ramp time is 10 seconds). The ramp will either step from one level to the other in 4.5 microsecond steps or will execute approximately 4000 steps at a time required to meet the ramp duration. For example, a ramp of 1 millisecond consists of 222 steps (4.5 microseconds per step). A ramp of 100 milliseconds consists of 4000 steps (25 microseconds per step). A ramp of 2 seconds consists of 4000 steps (0.5 milliseconds per step).

When using both ramps and transients at the same time, the following must be observed (see Figure B-1 for timing, see PAR. B.100 to initiate a transient pulse.):

- Transient <value> must be greater than set point if positive ramp and negative ramp are different.
- Transient pulse period <time> must exceed positive RAMP <time> by at least 1 millisecond.
- Transient <period> must be greater than (positive ramp <time> + negative ramp <time> + 0.002)
- Transient count can be from 1 to 65000.
- To configure Transient see PAR. B.30 for conductance, PAR. B.38 for current, PAR. B.50 for resistance and PAR. B.62 for voltage.

## B.107 SYSTem:RAMP? QUERY

## SYST:RAMP?

Syntax: Short Form: SYST:RAMP? Long Form: SYSTem:RAMP?  
Returns: <time> = the larger of SYST:RAMP:POS and SYST:RAMO:NEG

Description: **Indicates the larger of the positive and negative ramp times.** For example, If SYST:RAMP:POS is set to 2 and SYST:RAMP:NEG is set to 1.5, SYST:RAMP? returns 2.000.

## B.108 SYSTem:RAMP:POSitive COMMAND

## SYST:RAMP:POS

Syntax: Short Form: SYST:RAMP:POS <time> Long Form: SYSTem:RAMP:POSitive <time>  
Where <time> = positive ramp duration (Seconds) from 0.0001 to 2.000.

Description: **Establishes the time for unit to change states in positive direction.** See SYST:RAMP command, PAR. B.106 for ramp details. and restrictions.

## B.109 SYSTem:RAMP:POSitive? QUERY

## SYST:RAMP:POS?

Syntax: Short Form: SYST:RAMP:POS? Long Form: SYSTem:RAMP:POSitive?  
Returns: <time> = positive ramp duration (4Seconds) from 0.0001 to 2.000.

Description: **Indicates the positive ramp time.**

## B.110 SYSTem:RAMP:NEGative COMMAND

## SYST:RAMP:NEG

Syntax: Short Form: SYST:RAMP:NEG <time> Long Form: SYSTem:RAMP:NEGative <time>  
Where <time> = negative ramp duration (Seconds) from 0.0001 to 2.000.

Description: **Establishes the time for unit to change states in negative direction.** See SYST:RAMP command, PAR. B.106 for details and restrictions.

## B.111 SYSTem:RAMP:NEGative? QUERY

## SYST:RAMP:NEG?

Syntax: Short Form: SYST:RAMP:NEG? Long Form: SYSTem:RAMP:NEGative?  
Returns: <time> = negative ramp duration (Seconds) from 0.0001 to 2.000.

Description: **Indicates the negative ramp time.**

**B.112 SYSTem:RANGe:CURRent COMMAND****SYST:RANG:CURR**

Syntax: Short Form: SYST:RANG:CURR <txt> Long Form: SYSTem:RANGe:CURRent <txt>  
 Where <txt> = HIGH (HIGH = factory default) or LOW

Description: **Establishes range for remote interface current readback and front panel AMPS display.** LOW changes the current range to 1/10 of full scale. If the unit is 200A at full scale, entering SYST:RANG:LO, changes the ammeter range to 0 - 20A full scale.

**B.113 SYSTem:RANGe:CURRent? QUERY****SYST:RANG:CURR?**

Syntax: Short Form: SYST:RANG:CURR? Long Form: SYSTem:RANGe:CURRent?  
 Returns: <txt> = HIGH or LOW

Description: **Indicates the range for remote interface current readback and front panel AMPS display.**

**B.114 SYSTem:RANGe:POWer COMMAND****SYST:RANG:POW**

Syntax: Short Form: SYST:RANG:POW <txt> Long Form: SYSTem:RANGe:POWer <txt>  
 Where <txt> = HIGH or LOW (LOW = factory default)

Description: **Selects one of two power ranges, low (default) or high for remote interface power readback and KW meter on front panel.** The power ranges are a function of the full scale ammeter range. For example, for a 5 kW load (600A, 50V), the instrument inherently has a 600A full scale range. So at, for example, the 100V voltmeter range, the dynamic range of power measurement is: (0 - 100V) x 600A = 0 - 60,000 Watts, much higher than needed. Therefore, when the voltage is high and the current is low, SYST:RANG:POW LOW restricts the ammeter to 1/10th of full scale and thus, in this example, limits the maximum power reading to 6,000 Watts.

**B.115 SYSTem:RANGe:POWer? QUERY****SYST:RANG:POW?**

Syntax: Short Form: SYST:RANG:POW? Long Form: SYSTem:RANGe:POWer?  
 Returns: <txt> = HIGH or LOW (LOW = factory default)

Description: **Indicates one of two power ranges, low (1/10 full scale) or high for remote interface power readback and KW meter on front panel.**

**B.116 SYSTem:RANGe:VOLTage COMMAND****SYST:RANG:VOLT**

Syntax: Short Form: SYST:RANG:VOLT <Vrange> Long Form: SYSTem:RANGe:VOLTage <Vrange>  
 where <Vrange> = 100V, 200V, 400V or 800V

Description: **Establishes full scale voltage range of remote interface voltage readback and VOLTS display on front panel.** This setting is saved in non-volatile memory and is retained for subsequent power-up.

**B.117 SYSTem:RANGe:VOLTage? QUERY****SYST:RANG:VOLT?**

Syntax: Short Form: SYST:RANG:VOLT? Long Form: SYSTem:RANGe:VOLTage?  
 Returns: <Vrange> = 100V, 200V, 400V or 800V

Description: **Indicates full scale voltage range for remote interface voltage readback and VOLTS display on front panel.**

**B.118 SYSTem:REPLY COMMAND****SYST:REPLY**

Syntax: Short Form: SYST:REPLY <bool> Long Form: SYSTem:REPLY <bool>  
 Where <bool> = 0 or OFF = replies off or 1 (or ON) = replies ON

Description: **Turns reporting of error messages on (1) or off (0).** Turns on/off reporting of error messages generated when SCPI parser analyses SCPI commands. When set to 0, If command is understood, the EL load provides the normal or expected response. When set to 1, if command is understood, the EL load provides the normal or expected response, followed by OK. If the command is not understood, the EL Load responds with "###" and the appropriate error message is added to the error queue. (see PAR. B.95 for details).

**B.119 SYSTem:REPLY? QUERY****SYST:REPLY?**

Syntax: Short Form: SYST:REPLY? Long Form: SYSTem:REPLY?  
Returns: <bool> = 0 or 1

Description: **Indicates whether error message reporting is on (1) or off (0).**

**Caution:** When the GPIB/LAN interface is installed, SYST:REPLY **must** be on (1). Turning SYST:REPLY off (0) will cause all commands to take approximately 1 second to complete, and the responses to queries will have multiple CR LF pairs in front of the actual response.

**B.120 SYSTem:SERNumber? QUERY****SYST:SERN?**

Syntax: Short Form: SYST:SERN? Long Form: SYSTem:SERNumber?  
Returns: <NR3> where <NR3> = unit serial number

Description: **Returns unit serial number.**

**B.121 SYSTem:SETTings? QUERY****SYST:SETT?**

Syntax: Short Form: SYST:SETT? Long Form: SYSTem:SETTings?  
Returns: <txt> where <txt> = system settings (see below).

Description: **Display system settings (see sample response shown below).**

```

SYST:SETT?
KEPCO, EL 5K-200-600 01-18-2010,A999104,MCB #200 1.176 $ 2010/01/18 22:27:06 $

Chassis Serial Number: A999104
Voltage range: 400V
Current range: 595.5
System damping: 5
PFM damping: 3
Overvoltage limit: 799.0
Undrvoltage limit: 0.000
Overcurrent limit: 600.0
Overpower limit: 6.000
Max volt limit: 220.0
Max curr limit: 630.0
Max powr limit: 5.250
System mode (startup): CURRent
System mode (now): CURRent
Setpoints
  Voltage      : 220.0
  Current      : 0.000
  Power        : 0.000
  Resistance   : 1000.
  Conductance  : 0.255
Fan temperature limits (C)
  Lower: 40
  Upper: 70
IP Mode       : Static
IP Address: 0.0.0.0
Sub Net      : 0.0.0.0
Gateway      : 0.0.0.0
DNS Addr     : 0.0.0.0

```

**B.122 SYSTem:VERSion? QUERY****SYST:VERS?**

Syntax: Short Form: SYST:VERS? Long Form: SYSTem:VERSion?  
Returns:

Description: **Identify unit and firmware version.**

```

syst:vers?
KEPCO, EL 5K-200-600 01-18-1994,A999104,MCB #200 1.176 $ 2010/01/18 22:27:06 $

```

