

# OPERATOR'S MANUAL

## BOP-1KW (G)

### HIGH POWER BIPOLAR POWER SUPPLY

KEPCO INC.  
An ISO 9001 Company.

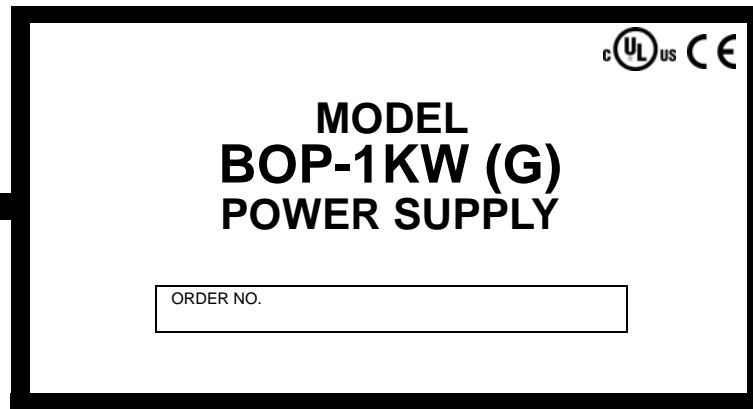

#### IMPORTANT NOTES:

- 1) This manual is valid for the following Firmware Versions:

FIRMWARE VERSION	NOTE.
3.05 and higher	
- 2) A Change Page may be included at the end of the manual. All applicable changes and revision number changes are documented with reference to the equipment serial numbers. Before using this Instruction Manual, check your equipment firmware version number to identify your model. If in doubt, contact your nearest Kepco Representative, or the Kepco Documentation Office in New York, (718) 461-7000, requesting the correct revision for your particular model and firmware version number.
- 3) The contents of this manual are protected by copyright. Reproduction of any part can be made only with the specific written permission of Kepco, Inc.

Data subject to change without notice.

©2024, KEPCO, INC  
P/N 243-1382-r4





## Conditions of Conformance

When this product is used in applications governed by the requirements of the EEC, the following restrictions and conditions apply:

1. For European applications, requiring compliance to the Low Voltage Directive, 73/23/EEC, this power supply is considered a component product, designed for "built in" applications. Because it is incomplete in construction, the end product enclosure must provide for compliance to any remaining electrical safety requirements and act as a fire enclosure. (EN61010-1 Cl. 6, Cl. 7, Cl.8, Cl. 9 and EN61010-1 annex F)
2. This power supply is designed for stationary installation, with mains power applied via a detachable power supply cord or via direct wiring to the source power terminal block.
3. This power supply is considered a Class 1 (earthed) product, and as such depends upon proper connection to protective earth for safety from electric shock. (EN61010-1 Cl. 6.5.4)
4. This power supply is intended for use as part of equipment meant for test, measurement and laboratory use, and is designed to operate from single phase, three wire power systems. This equipment must be installed within a suitably wired equipment rack, utilizing a three wire (grounded) mains connection. See wiring section of this manual for complete electrical wiring instructions. (EN61010-1 Cl. 6.5.4 and Cl.6.10.1)
5. This power supply has secondary output circuits that are considered hazardous, and which exceed 100V d-c, able to deliver current greater than 10A d-c.
6. The output wiring terminals of this power supply have not been evaluated for field wiring and, therefore, must be properly configured by the end product manufacturer prior to use.
7. This power supply employs a supplementary circuit protector in the form of a circuit breaker mounted on the front panel. This circuit breaker protects the power supply itself from damage in the event of a fault condition. For complete circuit protection of the end product, as well as the building wiring, it is required that a primary circuit protection device be fitted to the branch circuit wiring. (EN61010-1 Cl. 9.6.2)
8. Hazardous voltages are present within this power supply during normal operation. All operator adjustments to the product are made via externally accessible switches, controls and signal lines as specified within the product operating instructions. There are no user or operator serviceable parts within the product enclosure. Refer all servicing to qualified and trained Kepco service technicians.

# SAFETY INSTRUCTIONS

## 1. Installation, Operation and Service Precautions

This product is designed for use in accordance with EN 61010-1 and UL 3101 for Installation Category 2, Pollution Degree 2. Hazardous voltages are present within this product during normal operation. The product should never be operated with the cover removed unless equivalent protection of the operator from accidental contact with hazardous internal voltages is provided:



There are no operator serviceable parts or adjustments within the product enclosure. Refer all servicing to trained service technician.



Source power must be removed from the product prior to performing any servicing.



This product is factory-wired for the nominal a-c mains voltage indicated on the rating nameplate located adjacent to the source power connection on the product's rear panel. To reconfigure the product input for other nominal mains voltages as listed herein, the product must be modified by a trained service technician.

## 2. Grounding

This product is a Class 1 device which utilizes protective earthing to ensure operator safety.



The PROTECTIVE EARTHING CONDUCTOR TERMINAL must be properly connected prior to application of source power to the product (see instructions on installation herein) in order to ensure safety from electric shock.



PROTECTIVE EARTHING CONDUCTOR TERMINAL - This symbol indicates the point on the product to which the protective earthing conductor must be attached.



EARTH (GROUND) TERMINAL - This symbol is used to indicate a point which is connected to the PROTECTIVE EARTHING TERMINAL. The component installer/ assembler must ensure that this point is connected to the PROTECTIVE EARTHING TERMINAL.

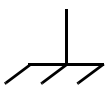

CHASSIS TERMINAL - This symbol indicates frame (chassis) connection, which is supplied as a point of convenience for performance purposes (see instructions on grounding herein). This is not to be confused with the protective earthing point, and may not be used in place of it.

## 3. Electric Shock Hazards

This product outputs hazardous voltage and energy levels as a function of normal operation. Operators must be trained in its use and exercise caution as well as common sense during use to prevent accidental shock.



This symbol appears adjacent to any external terminals at which hazardous voltage levels as high as 500V d-c may exist in the course of normal or single fault conditions.



This symbol appears adjacent to any external terminals at which hazardous voltage levels in excess of 500V d-c may exist in the course of normal or single fault conditions.

# OPERATOR SAFETY INSTRUCTIONS

Read these safety instructions, as well as the applicable installation and operating instructions contained in this manual before using the power supply.





Do not touch the output terminals. The output is dangerous. Electric shock can cause injury or death.

Do not remove the cover or disassemble the unit. There are no operator serviceable components or adjustments inside the unit. High voltage components inside the unit can cause serious injury even with input power disconnected.

Service must be referred to authorized personnel. Using the power supply in a manner not specified by Kepco, Inc. may impair the protection provided by the power supply. Observe all safety precautions noted throughout this manual. The following table lists symbols used on the power supply or in this manual where applicable.

The liquid in the LCD is hazardous: do not lick or swallow. Wash skin and clothes immediately and thoroughly upon exposure.

## SAFETY SYMBOLS

SYMBOL	Meaning
	WARNING: RISK OF ELECTRIC SHOCK. INDICATES THE POSSIBILITY OF BODILY INJURY OR DEATH.
	CAUTION: REFER TO REFERENCED PROCEDURE. INDICATES THE POSSIBILITY OF EQUIPMENT DAMAGE.

## CAUTION

If this power supply is used in OEM equipment, the OEM equipment manufacturer is responsible for attaching appropriate warning labels on the OEM equipment.

Operating the power supply outside the specified limits for input voltage, temperature, or other environmental conditions noted in this manual can damage the power supply and void the warranty.

DO NOT: wipe the front panel with hard materials, nor apply excessive force to the surface. DO NOT expose to extended periods of bright sunshine or UV light.

## Safety Messages

The BOP protection circuitry is designed to protect the load against unregulated high voltages and protect the BOP from extensive damage in the event of a component failure. Refer to Table 1-2 for more information regarding the protection circuits.

# LIST OF WARNINGS AND CAUTIONS

PAGE	WARNING/CAUTION
3-9	<b>WARNING:</b> For inductive loads, and especially superconducting magnet type loads, the inherent offset of the BOP in the OFF state may generate significant current in the circuit. Two properly rated external switches must be installed for safety: one in series between the power supply and the magnet, and the other in parallel with the magnet. Once the BOP front panel display reads 0V, 0A, close the parallel switch, then open the series switch before removing or installing connections between BOP and load. To restore normal operation, first close the series switch, then open the parallel switch.
3-9	<b>WARNING:</b> For both inductive loads and constant-current-type active electronic loads when the BOP output is set to OFF, a path is provided for absorbing either the energy accumulated in the reactance of the load during the ON state, or energy delivered by an electronic load. This prevents damage to the load and power supply as well as providing safety for the user. However, In addition to the built-in safety features, constant-current-type active electronic loads must be adjusted to zero and voltage and current measurements at the output must read 0V, minimum current, before handling the power supply-to-load connections.
3-10	<b>WARNING:</b> Accessing the BOP after the output is disabled in BATTERY mode is hazardous because (1) high current arcing is possible and (2) either the external battery voltage, or the voltage ( $\pm$ Voltage Protection max) on the BOP output terminals may be dangerous. Therefore, for battery and constant-voltage-type active electronic loads it is recommended that two properly rated external switches be installed for safety: one in series with the battery, and one across the BOP output. After the unit is set to OFF, first open the switch in series with the battery, then close the switch across the BOP output to ensure safety before handling BOP connections. When connecting the battery, the switch across the output should be opened after the connections are complete and then the switch in series with the battery should be closed. If the constant-voltage-type active electronic load is adjusted to zero before handling the power supply-to-load connections, only the switch across the BOP output is required.
4-9	<b>WARNING:</b> The sense resistor will be dissipating full rated current of the BOP. If it is hot to the touch, the sense resistor value, power rating and/or cooling are incorrect; refer to PAR. 4.3 and Table 4-2.
2-8	<b>CAUTION:</b> it is recommended that source power of external equipment connected to the Analog Port be applied through an isolating transformer to avoid ground loops or possible damage to the BOP due to incorrect equipment a-c wiring (e.g., defeating of ground connection).
2-10	<b>CAUTION:</b> DO NOT repeatedly toggle the POWER circuit breaker/switch as this may damage the unit.
2-11	<b>CAUTION:</b> DO NOT repeatedly toggle the POWER circuit breaker/switch as this may damage the unit.
2-11	<b>CAUTION:</b> The rack must provide support at the rear (within 6 inches of the rear panel). Optional slides can also be used (see PAR. 2.4.2).
2-12	<b>CAUTION:</b> When working with active loads, the voltage or current of the active load must not exceed the maximum voltage or current rating of the BOP. Otherwise the overvoltage or overcurrent protection will shut down the power supply.

# LIST OF WARNINGS AND CAUTIONS

PAGE	WARNING/CAUTION
2-14	<b>CAUTION:</b> Never connect the load to the sense terminals. Monitoring instruments (e.g., DVM, etc.) are the only external equipment that may be safely connected to the sense terminals.
2-14	<b>CAUTION:</b> Never connect the BOP OUTPUT terminal (or the load terminal tied to the OUTPUT terminal) to earth-ground. Otherwise, if the controlling device is grounded, the BOP can be damaged by the protection limit output current flowing inside the BOP along the programming signal return path.
2-14	<b>CAUTION:</b> Do not connect both the load and the programming device return (common) to earth-ground potential. Otherwise, if the COMMON power connection between the BOP and the load is lost, then the BOP can be damaged by output current flowing inside the BOP along the programming signal return path.
2-14	<b>CAUTION:</b> The safety features incorporated into the BOP to handle energy from Active loads are unable to protect the power supply or the load if input power to the BOP is lost or if the BOP Malfunctions. It is recommended that the user monitor "Power OK" flag pins 3 and 4 of the external Protect Port (see Table 2-6) and implement a fast-acting means of disconnecting capacitive loads or crowbaring inductive loads to prevent damage to both the BOP and the load in the event of input power loss.
2-17	<b>CAUTION:</b> To ensure correct operation, do not remove the GPIB cable from the BOP after a Query is processed. Ensure that the last command is a non-query such as *CLS before removing the GPIB cable. Otherwise, power to the BOP and/or the host computer may need to be cycled OFF then ON to restore proper operation.
2-19	<b>CAUTION:</b> For both parallel and series configurations, remove links between (COM S) and (COM OUT) terminals of all slaves to prevent damage to the unit and maintain system accuracy. Make sure to accurately follow Figures 2-7 through 2-10 for proper connection of the units.
2-25	<b>CAUTION:</b> For both parallel and series configurations, remove links between (COM S) and (COM OUT) terminals of all slaves to prevent damage to the unit and maintain system accuracy. Make sure to accurately follow Figures 2-7 through 2-10 for proper connection of the units.
3-1	<b>CAUTION:</b> Before connecting a load, note that the unit is will power-up with the configuration set by the power-up switches accessible through the top cover (see Table 2-2 for switch settings). Verify that these power-up settings are compatible with your load (see Figure 2-2 and Table 2-2 for switch settings).  To change to change load type, baud rate or Trigger port Remote on/off logic refer to PAR. 3.3.2.1; to change all other power-up settings listed below refer to PAR. 3.3.2.2.  In addition to the power-up settings determined by the switches accessed through the top cover, many unit parameters may be saved for the next power-up cycle using MEM:UPD commands (see PAR. B.12). When using MEM:UPD, it is recommended that the unit be tagged with the custom power-up configuration to avoid unexpected behavior upon power-up.
3-4	<b>CAUTION:</b> DO NOT repeatedly toggle the circuit breaker/switch as this may damage the unit.

# LIST OF WARNINGS AND CAUTIONS

PAGE	WARNING/CAUTION
3-5	<b>CAUTION:</b> DO NOT repeatedly toggle the circuit breaker/switch as this may damage the unit.
3-7	<b>CAUTION:</b> When working with active loads, always adjust the BOP protection limits to be above the maximum values of voltage or current expected from the load. For example, when the BOP is operating in voltage mode sinking energy from a constant current type load, set the current protection limits of the BOP above the maximum current expected from the load.
3-22	<b>CAUTION:</b> The commands listed above with (**) will generate a “-440, Missing Query” error if a query does not precede the command in the same command string or ;*OPC? does not follow the command. Although commands not marked with (**) will not generate an error, all commands listed above require verification to insure absolute success. Failure to follow these rules can result in the loss of all stored constants and render the unit inoperative.
3-23	<b>CAUTION:</b> If you are not sure what the saved settings are, disconnect the load before issuing *RCL. Then issue queries to identify the stored settings.
3-30	<b>CAUTION:</b> To ensure correct operation, do not remove the GPIB cable from the BOP after a Query is processed. Ensure that the last command is a non-query such as *CLS before removing the GPIB cable. Otherwise, power to the BOP and/or the host computer may need to be cycled OFF then ON to restore proper operation.
3-34	<b>CAUTION:</b> When the serial port has received an XOFF, the error message -400, “Query Error” will be placed in the queue to indicate the loss of transmitted information due to a received XOFF character. When XON is received, the unit will transmit all data in it's buffer followed by the exclamation character (!). This (!) character is not part of any message from the BOP and indicates the transmission buffer has been cleared and the BOP is idle.
B-5	<b>CAUTION:</b> When using MEM:UPD it is recommended that the unit be tagged with the saved configuration to avoid unexpected behavior upon power-up.



# TABLE OF CONTENTS

SECTION	PAGE
<b>SECTION 1 - INTRODUCTION</b>	
1.1	Scope of Manual ..... 1-1
1.2	General Description..... 1-1
1.3	Specifications ..... 1-1
1.4	Remote Control ..... 1-14
1.5	Features ..... 1-14
1.5.1	Digital Calibration..... 1-14
1.5.2	voltage/current Protection..... 1-14
1.5.3	Waveforms..... 1-14
1.5.4	Saving and Recalling Settings..... 1-14
1.5.5	External Reference (Analog Control)..... 1-15
1.5.6	External Limits ..... 1-15
1.5.7	User-defined Voltage/Current Maximum Values (Software Limits) ..... 1-15
1.5.8	Parallel and Series Configurations ..... 1-15
1.5.9	Energy Recuperation ..... 1-15
1.6	Equipment Supplied ..... 1-16
1.7	Accessories ..... 1-16
1.8	Safety ..... 1-16
<b>SECTION 2 - INSTALLATION</b>	
2.1	Unpacking and Inspection ..... 2-1
2.2	Terminations and Controls ..... 2-1
2.3	Preliminary Operational Check..... 2-9
2.3.1	Preliminary Operational Check using Analog Control..... 2-9
2.3.2	Preliminary Operational Check using Digital Control..... 2-10
2.4	Installation ..... 2-11
2.4.1	Rack Mounting..... 2-11
2.4.2	Slide Installation..... 2-11
2.5	Wiring Instructions..... 2-12
2.5.1	Safety Grounding..... 2-12
2.5.2	Source Power Connections ..... 2-12
2.5.3	D-C Output Grounding..... 2-12
2.5.3.1	Grounding Network Configuration..... 2-13
2.5.4	Power Supply/Load Interface..... 2-13
2.5.5	Load Connection - General..... 2-14
2.5.6	Load Connection Using Local Sensing..... 2-14
2.5.7	Load Connection Using Remote Sensing..... 2-15
2.6	Cooling ..... 2-15
2.7	Setting up the unit ..... 2-15
2.7.1	Power-up Settings ..... 2-15
2.7.2	Setup for Analog Control ..... 2-17
2.7.3	Setup for Digital Control via GPIB ..... 2-17
2.7.4	Setup for Digital Control via RS 232C ..... 2-17
2.8	Multiple Unit Configurations ..... 2-19
2.8.1	Multiple Unit Connections..... 2-19
2.8.2	Multiple Unit Source Power ..... 2-24
2.8.3	Multiple Unit Protection..... 2-24
2.8.4	Operating Instructions for Multiple Unit Combinations..... 2-25
2.8.5	Restoring a Unit to Standalone Operation ..... 2-26
<b>SECTION 3 - OPERATION</b>	
3.1	General..... 3-1
3.2	Power-up Settings ..... 3-1
3.2.1	Changing the Default Power-up Settings..... 3-2
3.3	Power Supply Basics..... 3-2
3.3.1	Controls and Indicators..... 3-2

# TABLE OF CONTENTS

SECTION		PAGE
3.3.2	Turning the Power Supply On.....	3-3
3.3.2.1	Reset Power-up .....	3-4
3.3.2.2	Normal Power-up .....	3-4
3.3.3	Voltage and Current Parameters .....	3-5
3.3.4	Voltage/Current Protect Settings .....	3-5
3.3.4.1	Hidden Voltage and Current Protect Limits .....	3-5
3.3.5	Maximum/Minimum Protection Limits (Software-controlled).....	3-7
3.3.5.1	Maximum Accepted Voltage or Current (Main Channel Software Limits) .....	3-7
3.3.6	Determining How the Unit responds when Output is OFF (Load Type).....	3-9
3.3.6.1	Battery Charging/Discharging using the BOP .....	3-11
3.3.6.1.1	Battery Operations using Voltage Mode.....	3-11
3.3.6.1.2	Battery Operations using Current Mode .....	3-11
3.3.7	External Limits .....	3-12
3.3.8	Enabling/Disabling DC Output Power .....	3-12
3.3.8.1	Remote Shutdown.....	3-12
3.3.8.2	Remote On-OFF Using Trigger Port Pin 2 .....	3-14
3.3.8.3	Remote On-OFF Using Trigger port (off) and Digital Command (on) .....	3-14
3.3.8.4	Remote On-OFF Using Digital Commands.....	3-14
3.3.9	Setting Main Channel Mode (Voltage or Current).....	3-15
3.3.10	Protection Limits .....	3-15
3.4	Analog Remote Mode Programming .....	3-16
3.4.1	Controlling the Output Using the BOP as a Power Amplifier .....	3-16
3.4.1.1	Fixed Gain using External Reference Control.....	3-17
3.4.1.2	Variable Gain Using External Reference Level.....	3-18
3.4.2	External Protection Limits .....	3-19
3.4.2.1	Using Lesser of Digital vs. Analog (External) limits.....	3-19
3.4.3	Monitoring Output Current Using an analog signal .....	3-20
3.5	Digital Control .....	3-20
3.5.1	Password Protection.....	3-20
3.5.2	Setting Operating Mode (Voltage or Current) .....	3-20
3.5.3	Programming Voltage or Current and Associated Protect Limits.....	3-20
3.5.4	Programming Associated Protect Limits .....	3-21
3.5.4.1	When Operating in Voltage Mode .....	3-21
3.5.4.2	When Operating in Current Mode .....	3-21
3.5.5	Programming Techniques to Optimize performance .....	3-22
3.5.5.1	Programming Voltage/Current Limit and Current/Voltage Limit .....	3-22
3.5.5.2	Making Sure the Previous Command is Complete .....	3-22
3.5.6	Storing/Recalling Power Supply Output Settings.....	3-23
3.5.7	Waveform Generation.....	3-24
3.5.7.1	Waveform Overview.....	3-24
3.5.7.2	Understanding How Waveforms Are Generated.....	3-25
3.5.7.3	Waveform Specifications.....	3-26
3.5.7.4	Executing a Waveform .....	3-26
3.5.7.5	Using Segments to Build a Waveform .....	3-27
3.5.8	Reset.....	3-28
3.5.9	Error Message Explanations .....	3-29
3.6	Programming Using Digital Control .....	3-29
3.6.1	BIT 4882 Compatibility.....	3-30
3.6.2	BIT 4886 Compatibility.....	3-30
3.6.3	IEEE 488 (GPIB) Bus Protocol .....	3-30
3.6.3.1	GPIB Port Setup.....	3-31
3.6.3.1.1	Changing the GPIB Address .....	3-31
3.6.3.1.2	Configure Device Clear (DCL) Control .....	3-32
3.6.3.1.3	Determining Whether *RST Command sets the Output Off or On .....	3-32
3.6.4	RS232-C Operation .....	3-32
3.6.4.1	Serial Interface .....	3-32
3.6.4.2	RS 232 Implementation.....	3-32

# TABLE OF CONTENTS

SECTION	PAGE
3.6.4.2.1	XON XOFF Method..... 3-34
3.6.4.2.2	Echo Mode..... 3-34
3.6.4.2.3	Prompt Method..... 3-35
3.6.4.3	RS 232 Serial Port Setup..... 3-35
3.6.4.3.1	Select Baud Rate..... 3-35
3.6.4.3.2	Configure Echo Protocol..... 3-35
3.6.4.3.3	Configure XON/XOFF Protocol..... 3-35
3.6.4.3.4	Configure Prompt Mode..... 3-36
3.6.5	BOP VISA Instrument driver..... 3-36
3.7	SCPI Programming..... 3-36
3.7.1	SCPI Messages..... 3-37
3.7.2	Common Commands/Queries..... 3-37
3.7.3	SCPI Subsystem Command/Query Structure..... 3-37
3.7.3.1	ABORt Subsystem..... 3-37
3.7.3.2	INITiate Subsystem..... 3-37
3.7.3.3	LIST Subsystem..... 3-37
3.7.3.3.1	Required LIST Commands..... 3-38
3.7.3.3.2	Other Required Commands..... 3-39
3.7.3.3.3	Other Useful Commands..... 3-39
3.7.3.3.4	Optional Commands..... 3-39
3.7.3.4	MEASure Subsystem..... 3-39
3.7.3.5	OUTPut Subsystem..... 3-39
3.7.3.6	MEMory Subsystem..... 3-40
3.7.3.7	STATus Subsystem..... 3-42
3.7.3.8	TRIGger subsystem..... 3-42
3.7.3.9	[SOURce:]VOLTage and [SOURce:]CURRent Subsystems..... 3-42
3.7.3.10	CALibrate Subsystem..... 3-43
3.7.3.11	System Subsystem..... 3-43
3.7.3.11.1	Forgotten Passwords..... 3-43
3.7.4	Program Message Structure..... 3-44
3.7.4.1	Keyword..... 3-44
3.7.4.2	Keyword Separator..... 3-44
3.7.4.3	Query Indicator..... 3-45
3.7.4.4	Data..... 3-45
3.7.4.5	Data Separator..... 3-45
3.7.4.6	Message Unit Separator..... 3-45
3.7.4.7	Root Specifier..... 3-45
3.7.4.8	Message Terminator..... 3-46
3.7.5	Understanding The Command Structure..... 3-46
3.7.6	Program Message Syntax Summary..... 3-47
3.7.7	Status Reporting..... 3-47
3.7.7.1	Status Reporting Structure..... 3-47
3.7.7.2	Operational Status Register..... 3-49
3.7.7.3	QUESTionable Status Register..... 3-49
3.7.8	SCPI Program Examples..... 3-50
3.8	Operator Troubleshooting..... 3-50
 <b>SECTION 4 - CALIBRATION</b>	
4.1	General..... 4-1
4.2	Test Equipment Requirements..... 4-3
4.3	Calibration using Remote SCPI commands via GPIB or RS 232 Interface..... 4-4
4.3.1	Calibration Procedure using SCPI Commands..... 4-6
4.3.2	Calibration of Series- or Parallel-Connected Units..... 4-11
4.4	Calibration Storage..... 4-11
 <b>APPENDIX A - SCPI COMMON COMMAND/QUERY DEFINITIONS</b>	

# TABLE OF CONTENTS

SECTION		PAGE
A.2	*CLS — Clear Status Command .....	A-1
A.3	*ESE — Standard Event Status Enable Command.....	A-1
A.4	*ESE? — Standard Event Status Enable Query.....	A-2
A.5	*ESR? — Event Status Register Query.....	A-2
A.6	*IDN? — Identification Query.....	A-2
A.7	*OPC — Operation Complete Command .....	A-2
A.8	*OPC? — Operation Complete Query .....	A-3
A.9	*OPT? — Options Query .....	A-4
A.10	*RCL — Recall Command .....	A-4
A.11	*RST — Reset Command.....	A-4
A.12	*SAV — Save Command.....	A-4
A.13	*SRE — Service Request Enable Command .....	A-5
A.14	*SRE? — Service Request Enable Query .....	A-5
A.15	*STB? — Status Byte Register Query .....	A-5
A.16	*TRG — Trigger Command .....	A-5
A.17	*TST? — Self Test Query .....	A-6
A.18	*WAI — Wait-To-Continue Command .....	A-6

## APPENDIX B - SCPI COMMAND/QUERY DEFINITIONS

B.1	Introduction.....	B-1
B.2	Numerical Values.....	B-2
B.3	ABORT Command.....	B-2
B.4	CAL Commands and Queries.....	B-2
B.5	INITiate[:IMMediate] Command .....	B-3
B.6	INITiate:CONTInuous Command .....	B-4
B.7	INITiate:CONTInuous Query .....	B-4
B.8	MEASure[:SCALar]:CURRent[:DC]? Query .....	B-4
B.9	MEASure[:SCALar]:MODE[:DC] Command .....	B-4
B.10	MEASure[:SCALar]:VOLTag[:DC]? Query .....	B-4
B.11	MEASure[:SCALar]:TRANSient[:DC]? QUERY.....	B-4
B.12	MEMory:UPDate Command .....	B-5
B.13	OUTPut[:STATe] Command.....	B-6
B.14	OUTPut[:STATe] Query .....	B-7
B.15	OUTPut:CONTrol Command .....	B-7
B.16	OUTPut:CONT? Query .....	B-7
B.17	OUTPut:MODE Command.....	B-7
B.18	OUTPut:MODE? Query.....	B-7
B.19	[SOURce:]CURRent[:LEVel][:IMMediate][:AMPLitude] Command.....	B-7
B.20	[SOURce:]CURRent[:LEVel][:IMMediate][:AMPLitude] Query .....	B-8
B.21	[SOURce:]CURRent[:LEVel]:LIMit[:BOTH] Command.....	B-8
B.22	[SOURce:]CURRent[:LEVel]:LIMit[:BOTH]? Query.....	B-9
B.23	[SOURce:]CURRent[:LEVel]:LIMit:NEG Command .....	B-9
B.24	[SOURce:]CURRent[:LEVel]:LIMit:NEG? Query .....	B-9
B.25	[SOURce:]CURRent[:LEVel]:LIMit:POS Command .....	B-9
B.26	[SOURce:]CURRent[:LEVel]:LIMit:POS? Query .....	B-9
B.27	[SOURce:]CURRent:MODE Command.....	B-10
B.28	[SOURce:]CURRent:MODE? Query .....	B-10
B.29	[SOURce:]CURRent[:LEVel]:PROTect[:BOTH] Command.....	B-10
B.30	[SOURce:]CURRent[:LEVel]:PROTect[:BOTH] Query .....	B-10
B.31	[SOURce:]CURRent[:LEVel]:PROTect:MODE Command .....	B-11
B.32	[SOURce:]CURRent[:LEVel]:PROTect:MODE? Query .....	B-11
B.33	[SOURce:]CURRent[:LEVel]:PROTect:NeGative Command .....	B-11
B.34	[SOURce:]CURRent[:LEVel]:PROTect:NeGative? Query .....	B-11
B.35	[SOURce:]CURRent[:LEVel]:PROTect:POSitive Command .....	B-11
B.36	[SOURce:]CURRent[:LEVel]:PROTect:POSitive? Query .....	B-11

# TABLE OF CONTENTS

SECTION		PAGE
B.37	[SOURCE:]CURRENT[:LEVEL]:PROTECT:LIMIT[:BOTH] Command.....	B-11
B.38	[SOURCE:]CURRENT[:LEVEL]:PROTECT:LIMIT[:BOTH]? Query.....	B-12
B.39	[SOURCE:]CURRENT[:LEVEL]:PROTECT:LIMIT:NEGATIVE Command.....	B-12
B.40	[SOURCE:]CURRENT[:LEVEL]:PROTECT:LIMIT:NEGATIVE? Query.....	B-12
B.41	[SOURCE:]CURRENT[:LEVEL]:PROTECT:LIMIT:POSITIVE Command.....	B-12
B.42	[SOURCE:]CURRENT[:LEVEL]:PROTECT:LIMIT:POSITIVE? Query.....	B-12
B.43	[SOURCE:]CURRENT[:LEVEL]:TRIGGERED[:AMPLITUDE] Command.....	B-12
B.44	[SOURCE:]CURRENT[:LEVEL]:TRIGGERED[:AMPLITUDE]? Query.....	B-13
B.45	[SOURCE:]FUNCTION:MODE Command.....	B-13
B.46	[SOURCE:]FUNCTION:MODE? Query.....	B-13
B.47	[SOURCE:]FUNCTION:MODE:TRIGGER Command.....	B-13
B.48	[SOURCE:]FUNCTION:MODE:TRIGGER? Query.....	B-13
B.49	[SOURCE:]LIST:CLEAR Command.....	B-13
B.50	[SOURCE:]LIST:COUNT Command.....	B-13
B.51	[SOURCE:]LIST:COUNT? Query.....	B-13
B.52	[SOURCE:]LIST:COUNT:SKIP Command.....	B-14
B.53	[SOURCE:]LIST:COUNT:SKIP? Query.....	B-15
B.54	[SOURCE:]LIST:CURRENT Command.....	B-15
B.55	[SOURCE:]LIST:CURRENT? Query.....	B-16
B.56	[SOURCE:]LIST:CURRENT:APPLY Command.....	B-16
B.57	[SOURCE:]LIST:CURRENT:APPLY:SWEPT Command.....	B-16
B.58	[SOURCE:]LIST:CURRENT:APPLY:SWEPT? Query.....	B-16
B.59	[SOURCE:]LIST:CURRENT:POINTS? Query.....	B-16
B.60	[SOURCE:]LIST:DIVIDER Command.....	B-17
B.61	[SOURCE:]LIST:DIVIDER? Query.....	B-17
B.62	[SOURCE:]LIST:DWELL Command.....	B-17
B.63	[SOURCE:]LIST:DWELL? Query.....	B-17
B.64	[SOURCE:]LIST:DWELL:POINTS? Query.....	B-17
B.65	[SOURCE:]LIST:QUERY Command.....	B-17
B.66	[SOURCE:]LIST:QUERY? Query.....	B-18
B.67	[SOURCE:]LIST:REPEAT Command.....	B-18
B.68	[SOURCE:]LIST:RESOLUTION? Query.....	B-18
B.69	[SOURCE:]LIST:SAMPLE:CURRENT Command.....	B-18
B.70	[SOURCE:]LIST:SAMPLE:VOLTAGE Command.....	B-19
B.71	[SOURCE:]LIST:SAMPLE? Query.....	B-19
B.72	[SOURCE:]LIST:SET:SAMPLE Command.....	B-19
B.73	[SOURCE:]LIST:SET:SAMPLE? Query.....	B-19
B.74	[SOURCE:]LIST:SET:TRIGGER Command.....	B-19
B.75	[SOURCE:]LIST:SET:TRIGGER? QUERY.....	B-20
B.76	[SOURCE:]LIST:SET:WAIT Command.....	B-20
B.77	[SOURCE:]LIST:SET:WAIT? QUERY.....	B-20
B.78	[SOURCE:]LIST:TRIGGER Command.....	B-20
B.79	[SOURCE:]LIST:VOLTAGE Command.....	B-20
B.80	[SOURCE:]LIST:VOLTAGE? Query.....	B-20
B.81	[SOURCE:]LIST:VOLT:APPLY Command.....	B-24
B.82	[SOURCE:]LIST:VOLTAGE:APPLY:SWEPT Command.....	B-24
B.83	[SOURCE:]LIST:VOLTAGE:APPLY:SWEPT? Query.....	B-24
B.84	[SOURCE:]LIST:VOLTAGE:POINTS? Query.....	B-24
B.85	[SOURCE:]LIST:WAIT:HIGH Command.....	B-25
B.86	[SOURCE:]LIST:WAIT:LEDGE Command.....	B-25
B.87	[SOURCE:]LIST:WAIT:LOW Command.....	B-25
B.88	[SOURCE:]VOLTAGE[:LEVEL][:IMMEDIATE][:AMPLITUDE] Command.....	B-26
B.89	[SOURCE:]VOLTAGE[:LEVEL][:IMMEDIATE][:AMPLITUDE]? Query.....	B-27
B.90	[SOURCE:]VOLTAGE[:LEVEL]:LIMIT[:BOTH] Command.....	B-27
B.91	[SOURCE:]VOLTAGE[:LEVEL]:LIMIT[:BOTH]? Query.....	B-27
B.92	[SOURCE:]VOLTAGE[:LEVEL]:LIMIT:NEGATIVE Command.....	B-27
B.93	[SOURCE:]VOLTAGE[:LEVEL]:LIMIT:NEGATIVE? Query.....	B-27

## TABLE OF CONTENTS

SECTION	PAGE
B.94	[SOURCE:]VOLTage[:LEVel]:LIMit:positive Command ..... B-27
B.95	[SOURCE:]VOLTage[:LEVel]:LIMit:positive? Query ..... B-27
B.96	[SOURCE:]VOLTage:MODE Command..... B-28
B.97	[SOURCE:]VOLTage:MODE? Query ..... B-28
B.98	[SOURCE:]VOLTage[:LEVel]:PROTect:BOTH Command ..... B-28
B.99	[SOURCE:]VOLTage[:LEVel]:PROTect[:BOTH]? Query ..... B-29
B.100	[SOURCE:]VOLTage[:LEVel]:PROTect:MODE Command..... B-29
B.101	[SOURCE:]VOLTage[:LEVel]:PROTect:MODE? Query ..... B-29
B.102	[SOURCE:]VOLTage[:LEVel]:PROTect:NeGative Command..... B-29
B.103	[SOURCE:]VOLTage[:LEVel]:PROTect:NeGative? Query ..... B-29
B.104	[SOURCE:]VOLTage[:LEVel]:PROTect:POSitive Command..... B-30
B.105	[SOURCE:]VOLTage[:LEVel]:PROTect:POSitive? Query ..... B-30
B.106	[SOURCE:]VOLTage[:LEVel]:PROTect:LIMit:BOTH Command ..... B-30
B.107	[SOURCE:]VOLTage[:LEVel]:PROTect:LIMit[:BOTH]? Query ..... B-30
B.108	[SOURCE:]VOLTage[:LEVel]:PROTect:LIMit:NeGative Command..... B-30
B.109	[SOURCE:]VOLTage[:LEVel]:PROTect:LIMit:NeGative? Query ..... B-30
B.110	[SOURCE:]VOLTage[:LEVel]:PROTect:LIMit:POSitive Command..... B-31
B.111	[SOURCE:]VOLTage[:LEVel]:PROTect:LIMit:POSitive? Query ..... B-31
B.112	[SOURCE:]VOLTage[:LEVel]:TRIGgered[:AMPlitude] Command ..... B-31
B.113	[SOURCE:]VOLTage[:LEVel]:TRIGgered[:AMPlitude]? Query ..... B-31
B.114	STATus:OPERation:CONDition? Query ..... B-31
B.115	STATus:OPERation:ENABle Command ..... B-32
B.116	STATus:OPERation:ENABle? Query ..... B-32
B.117	STATus:OPERation[:EVENT] Query ..... B-32
B.118	STATus:PRESet Command..... B-32
B.119	STATus:QUESTionable[:EVENT]? Query ..... B-32
B.120	STATus:QUESTionable:CONDition? Query ..... B-32
B.121	STATus:QUESTionable:ENABle Command ..... B-33
B.122	STATus:questionable:ENABle? Query ..... B-34
B.123	SYSTem:BEEP Command ..... B-34
B.124	SYSTem:COMMunication:GPIB:ADDResS Command ..... B-34
B.125	SYSTem:COMMunication:GPIB:ADDResS? Query ..... B-34
B.126	SYSTem:COMMunication:SERial:BAUD Command ..... B-34
B.127	SYSTem:COMMunication:SERial:BAUD? Query ..... B-34
B.128	SYSTem:COMMunication:SERial:ECHO Command ..... B-34
B.129	SYSTem:COMMunication:SERial:ECHO? Query ..... B-34
B.130	SYSTem:COMMunication:SERial:PACe Command ..... B-35
B.131	SYSTem:COMMunication:SERial:PACe? Query ..... B-35
B.132	SYSTem:COMMunication:SERial:PRoMpt CommanD..... B-35
B.133	SYSTem:COMMunication:SERial:PRoMpt? Query ..... B-35
B.134	SYSTem:ERRor? Query ..... B-35
B.135	SYSTem:ERRor:CODE? Query ..... B-35
B.136	SYSTem:ERRor:CODE:ALL? Query..... B-35
B.137	SYSTem:KEYBoard Command ..... B-35
B.138	SYSTem:KEYBoard? Query ..... B-36
B.139	SYSTem:PASSword:CENable Command ..... B-36
B.140	SYSTem:PASSword:CDISable Command ..... B-36
B.141	SYSTem:PASSword:NEW Command ..... B-36
B.142	SYSTem:PASSword:STATe? Query ..... B-36
B.143	SYSTem:REMoTe Command ..... B-36
B.144	SYSTem:REMoTe? Query ..... B-36
B.145	SYSTem:SECurity:IMMEdiate Command..... B-37
B.146	SYSTem:SET Command..... B-37
B.147	SYSTem:SET? Query ..... B-37
B.148	SYSTem:VERsion? Query ..... B-37
B.149	TRIGger:SOURce Command ..... B-38
B.150	TRIGger:SOURce? Query ..... B-38

# LIST OF FIGURES

FIGURE	TITLE	PAGE
1-1	High Power BOP-G Series Power Supply.....	X
1-2	BOP-G Power Supply, Outline Drawing.....	1-12
1-3	BOP Output Characteristics.....	1-17
2-1	BOP-G Series Rear Panel.....	2-1
2-2	BOP-G Top Cover Accessible Components.....	2-3
2-3	Factory Default Power-up Switch Settings.....	2-10
2-4	Load Connections, Local Sensing.....	2-16
2-5	Load Connections, Remote Sensing.....	2-16
2-6	Connections for Analog Control and Monitoring of BOP-G Power Supply.....	2-18
2-7	Parallel Configuration, Local Sensing, Typical.....	2-20
2-8	Parallel Configuration, Remote Sensing, Typical.....	2-21
2-9	Series Configuration, Local Sensing, Typical.....	2-22
2-10	Series Configuration, Remote Sensing, Typical.....	2-23
2-11	Typical Master/Slave Protection Interconnections.....	2-24
3-1	BOP-G Series Front Panel.....	3-3
3-2	Remote Shutdown Using External Power, Standalone or Multiple units.....	3-13
3-3	Remote Shutdown Using Internal Power, Standalone Units.....	3-13
3-4	Remote Shutdown Using Internal Power, Multiple Units.....	3-13
3-5	Remote On-Off, Standalone or Multiple Units.....	3-14
3-6	Programming Example to Verify Previous Command has Completed.....	3-24
3-7	Sample Waveform.....	3-26
3-8	RS 232 Implementation.....	3-33
3-9	Tree Diagram of SCPI Commands Used with BOP Power Supply.....	3-41
3-10	Message Structure.....	3-45
3-11	Status Reporting Structure.....	3-48
3-12	Typical Example Of BOP Power Supply Program Using SCPI Commands.....	3-51
4-1	Calibration Setup in Voltage Mode.....	4-6
4-2	Calibration Setup in Current Mode.....	4-9
A-1	GPIB Commands.....	A-3
B-1	Programming the Output.....	B-3
B-2	Using List Commands to measure sample at End of Pulse.....	B-5
B-3	Using List Commands to measure sample at Start of Pulse.....	B-6
B-4	Setting Limits.....	B-8
B-5	Using LIST Commands and Queries.....	B-14
B-6	Using LIST Commands for Sawtooth and Triangle Waveforms.....	B-21
B-7	Using List:WAIT Commands to Control Generation of a Waveform Measured by Multiple External Devices using a Single External Pulse.....	B-22
B-8	Using List:WAIT Commands to allow an external device time to function while imposing a maximum wait time.....	B-23
B-9	Using List:WAIT Commands to Control Generation of a Waveform Measured by Multiple External Devices using the Low-Going leading Edge of an External Pulse.....	B-26
B-10	Using PROT:LIM:POS and PROT:LIM:POS Commands to Set Asymmetrical Limits.....	B-29
B-11	Using Status Commands and Queries.....	B-33
B-12	Setting the Unit to Remote Mode via Serial (RS 232) Port.....	B-36
B-13	Using System Commands and Queries.....	B-37

## LIST OF TABLES

TABLE	TITLE	PAGE
1-1	BOP-G 1000 Watt Model Parameters .....	1-1
1-2	BOP General Specifications .....	1-2
1-3	Equipment Supplied .....	1-16
1-4	Safety Symbols .....	1-16
1-5	Accessories .....	1-18
2-1	Rear Panel Connector Functions .....	2-2
2-2	Power-Up Setup Switches .....	2-3
2-3	IEEE 1118 Connector Input/Output Pin Assignments .....	2-4
2-4	Trigger Port Pin Assignments .....	2-5
2-5	External Protection Connector Input/Output Pin Assignments .....	2-5
2-6	RS232C PORT Input/Output Pin Assignments .....	2-6
2-7	Parallel/Serial Control Out Port Pin Assignments .....	2-6
2-8	Parallel/Serial Control In Port Pin Assignments .....	2-6
2-9	Parallel/Serial Protect In Port Pin Assignments .....	2-7
2-10	Parallel/Serial Protect Out Port Pin Assignments .....	2-7
2-11	Analog I/O Port Input/Output Pin Assignments .....	2-8
2-12	IEEE 488 Port Input/Output Pin Assignments .....	2-9
3-1	Front Panel Controls and Indicators .....	3-3
3-2	Voltage and Current Parameter Definitions .....	3-6
3-3	Power Supply Behavior when Output is set to OFF .....	3-10
3-4	Sine, Triangle and Ramp Waveform Frequency vs. Points .....	3-25
3-5	Square Waveform Frequency vs. Points .....	3-26
3-6	Waveform Segment Details .....	3-27
3-7	Operation of #RST Command .....	3-29
3-8	IEEE 488 (GPIB) Bus Interface Functions .....	3-30
3-9	IEEE 488 (GPIB) Bus Command Mode Messages .....	3-31
3-10	IEEE 488 (GPIB) Bus Data Mode Messages .....	3-31
3-11	Rules Governing Shortform Keywords .....	3-44
4-1	Calibration Summary .....	4-1
4-2	Suggested Sense Resistors .....	4-3
4-3	Voltage Calibration Measurements and Tolerances .....	4-4
4-4	Current Calibration Measurements and Tolerances .....	4-5
4-5	Calibration Storage .....	4-12
A-1	IEEE 488.2 Command/query Index .....	A-1
A-2	Standard Event Status Enable Register and Standard Event Status Register Bits .....	A-1
A-3	Service Request Enable and Status Byte Register Bits .....	A-5
A-4	Built-in test Error Codes .....	A-6
B-1	SCPI Subsystem Command/query Index .....	B-1
B-2	List Data Table .....	B-16
B-3	Operation Condition Register, Operation Enable Register, and Operation Event Register Bits .....	B-31
B-4	Questionable Event Register, Questionable Condition Register and Questionable Condition Enable Register Bits .....	B-32
B-5	Error Messages .....	B-38





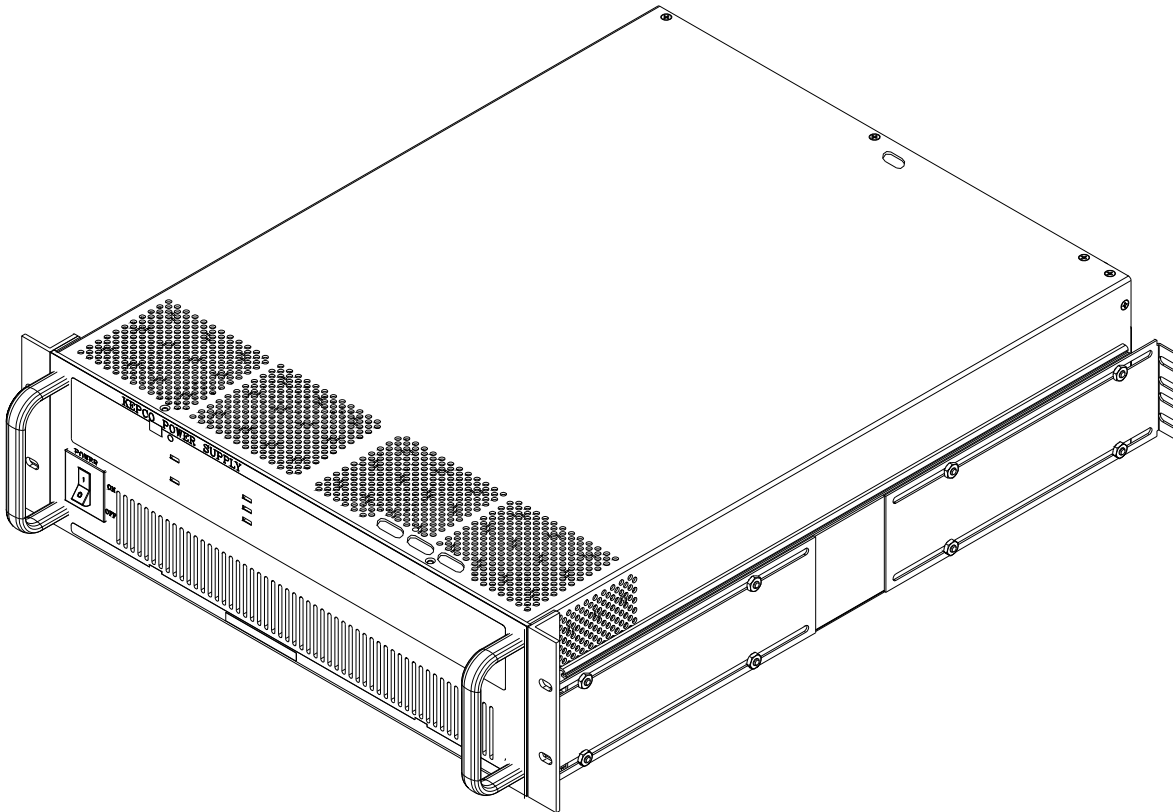

3043424

**FIGURE 1-1. HIGH POWER BOP-G SERIES POWER SUPPLY**

## SECTION 1 - INTRODUCTION

### 1.1 SCOPE OF MANUAL

This manual contains instructions for the installation, operation and servicing of the BOP-G series of 1000 Watt rack-mounted, 4-quadrant bipolar, programmable, voltage and current stabilized d-c power supplies manufactured by Kepco, Inc., Flushing, New York, U.S.A.

### 1.2 GENERAL DESCRIPTION

The BOP-G Series (Figure 1-1), hereafter referred to as BOP, are true 4-quadrant programmable voltage and current power supplies, meaning they are capable of both sourcing and sinking power. These bipolar power supplies pass smoothly through zero without switching to provide true  $\pm$  voltage and  $\pm$  current. These BOP power supplies use switch mode technology for low dissipation. A bi-directional, isolating, a-c input power factor correcting (PFC) circuit recuperates energy sunk from an active load and sends it back into the line to maintain low dissipation.

These BOP power supplies can be controlled remotely by an analog  $\pm 10V$  input for the main channel (voltage or current), and by a +1 to +10V input for the limit channels. They can also be controlled through one of the standard digital interfaces (GPIB or RS 232) to set voltage and current and the four protection limits (+voltage, -voltage, +current and -current.) Output current can be remotely monitored via the analog monitor signal present at the rear panel Analog I/O Port connector. Both output voltage and current can be monitored by using SCPI commands via either the RS 232 or GPIB ports.

### 1.3 SPECIFICATIONS

Table 1-1 below indicates parameters that vary for different 1000 Watt BOP-G models; Table 1-2 lists general specifications that apply to all 1000 Watt BOP-G models

**TABLE 1-1. BOP-G 1000 WATT MODEL PARAMETERS**

Model	d-c Output Range		Closed Loop Gain		Output Impedance			
	Voltage (V d-c)	Current (A d-c)	Voltage Channel $G_V$ (V/V)	Current Channel $G_I$ (A/V)	Voltage Mode (Series R - L)		Current Mode (Parallel R - C)	
					$R_{d-c}$ (mOhms)	L ( $\mu$ H)	$R_{d-c}$ (Ohms)	C ( $\mu$ F)
1000 WATT MODELS								
BOP 6-125G	0 to $\pm 6$	0 to $\pm 125$	0.6	12.5	0.05	1.5	24	1150
BOP 10-100G	0 to $\pm 10$	0 to $\pm 100$	1.0	10.0	0.1	2.0	50	1100
BOP 10-75G	0 to $\pm 10$	0 to $\pm 75$	1.0	7.5	0.13	2.0	67	976
BOP 20-50G	0 to $\pm 20$	0 to $\pm 50$	2.0	5.0	0.40	8.3	200	371
BOP 25-40G	0 to $\pm 25$	0 to $\pm 40$	2.5	4.0	0.63	15.8	313	165
BOP 36-28G	0 to $\pm 36$	0 to $\pm 28$	3.6	2.8	1.30	25	640	103
BOP 50-20G	0 to $\pm 50$	0 to $\pm 20$	5.0	2.0	2.50	50	1250	55
BOP 72-14G	0 to $\pm 72$	0 to $\pm 14$	7.2	1.4	5.14	104	2570	33
BOP 100-10G	0 to $\pm 100$	0 to $\pm 10$	10.0	1.0	10.0	163	5000	16
NOTE: When connecting active loads, the steady-state voltage of the active load must not exceed the maximum voltage rating of the BOP. Otherwise the overvoltage protection will shut down the power supply.								

**TABLE 1-2. BOP GENERAL SPECIFICATIONS**

SPECIFICATION		RATING/DESCRIPTION	CONDITION
<b>INPUT CHARACTERISTICS</b>			
a-c voltage	nominal	200/220/230/240Va-c <sup>(1)</sup> (200-240 Va-c)	No setting required. Single phase or between 2 phases of a 3-phase system within 200-240Va-c.
	range	176 - 264 Va-c	Continuous; Input voltage outside range causes protection fault.
Frequency	nominal	50-60 Hz	
	range	47 - 63 Hz	
Current	176 Va-c	9.5A	maximum
	264 Va-c	6.4A	maximum
Power factor	Source	0.99 minimum	nominal output power
	Sink	0.97 minimum	
Efficiency	Source	65% to 75% (model dependent) 56%/65% <sup>(2)</sup>	Minimum value, @Nominal sourced output power (V-I quadrant 1 & 3)
	Sink	50% to 65% (model dependent) 45%/43% <sup>(2)</sup>	Minimum value, @Nominal sink output power (V-I quadrant 2 & 4)
Switching frequency		70 KHz	PFC Stage, 5% tolerance
EMC Compliance		EN61326-1 (1997)	Class A equipment
EMC immunity to:	ESD	EN61000-4-2	Electrostatic discharge
	Radiated RF	EN61000-4-3	
	EFT	EN61000-4-4	Electrical fast transient/burst
	Surges	EN61000-4-5	
	Conducted RF	EN61000-4-6	
EMC emissions	Conducted	EN61000-3-2	harmonics
		EN61000-3-3	fluctuation & flicker
	Conducted	EN55011/CISPR11	0.15 to 30 MHz
	Radiated	EN55011/CISPR11	30 to 1000 MHz
Leakage current		3.5 mA	230V a-c, 60 Hz
Insulation coordination	Input	Installation Category II	for TN or TT power systems
		Overvoltage Category II	
	Output	Installation Category II	maximum 300V (500V for BOP 10-100G) isolation voltage between each output terminal and chassis ground.
		Overvoltage Category II	
Pollution degree		2	
<b>OUTPUT CHARACTERISTICS <sup>(3)</sup></b>			
Type of stabilizer		Voltage-Current, 4 quadrant	Switch mode
Switching frequency		100KHz	Output Stage, 5% tolerance
Source adjustment range	voltage	-100% to +100% of rating <sup>(4)</sup>	0 to 50 deg C
	current	-100% to +100% of rating <sup>(4)</sup>	
Sink adjustment range	voltage	-100% to +100% of rating <sup>(4)</sup>	0 to 50 deg C. Recuperated energy is sent back into line for general reuse.
	current	-100% to +100% of rating <sup>(4)</sup>	
<p>(1) All specifications listed in this table are for 230V a-c input voltage.  (2) BOP 6-125G and BOP 10-75G only.  (3) Output characteristics are for a single standalone unit.  (4) Rating means nominal output voltage (E<sub>O</sub>NOM) or nominal output current (I<sub>O</sub>NOM)</p>			

**TABLE 1-2. BOP GENERAL SPECIFICATIONS (Continued)**

SPECIFICATION		RATING/DESCRIPTION	CONDITION
<b>OUTPUT CHARACTERISTICS (Continued)</b>			
Analog Programming accuracy	Voltage	0.01% of rating	<ul style="list-style-type: none"> <li>Voltage and Current limit in Voltage Mode and Current and Voltage Limit in Current Mode.</li> <li>The programming signal is 0V to <math>\pm 10V</math> for 0 to <math>\pm E_{Onom}</math> (Voltage mode) or for 0 to <math>\pm I_{Onom}</math> (Current mode).</li> <li>The programming signal is +1V to +10V for 10% to 100% of all four limits (<math>\pm</math>voltage, <math>\pm</math>current)</li> <li>Input impedance is 20KOhms for the main channel (voltage or current)</li> <li>When the limit channels are not used, the limits are clamped to 1% above the nominal values.</li> <li>The limit source must be able to sink a maximum 0.15mA @ +1V programming signal</li> <li>Gain adjustable range: 10% (recommended) to 100% of nominal gain.</li> </ul>
	Current Limit	0.1% of rating	
	Current	0.1% of rating	
	Voltage Limit	0.3% of rating	
	Voltage, variable gain	3% of rating	
	Current, variable gain	4% of rating	
Analog Readback Accuracy	Voltage	—	<ul style="list-style-type: none"> <li>The analog readback signal is 0V to <math>\pm 10V</math> for 0 to <math>\pm</math> Nominal values for voltage and current.</li> <li>Output impedance of the analog readback signal is <math>&lt;0.1</math> Ohm</li> <li>The output current is maximum 5mA.</li> <li>Accuracy is for d-c or very low frequency a-c signals.</li> </ul>
	Current	0.1%	
Digital Programming resolution / accuracy	Voltage	14 bits / 0.05%	Voltage and Current limit in Voltage Mode and Current and Voltage Limit in Current Mode
	Current Limit	12 bits / 0.1%	
	Current	14 bits / 0.05%	
	Voltage Limit	12 bits / 0.1% (source), 0.2% (sink)	
Digital Readback resolution / accuracy	Voltage	16 bits / 0.05%	main or limit channel
	Current	16 bits / 0.05%	main or limit channel
Digital Sustain Output update rate		400 updates/sec	voltage or current
Digital Readback	measurement rate	5 ms	
	measurement array	64 samples	voltage and current
	rejection of line-related ripple/noise	50, 60, 125Hz	Digital readback (see PAR. B.9).
Voltage stabilization in voltage mode (digital or analog control)	source effect	0.05% of rating	min-max input voltage, 230V a-c reference
	load effect	0.1% of rating	0-100% load current
	time effect (drift)	0.01% of rating	0.5 through 8 hours
	temperature effect	0.02% of rating/deg C	0 to 50 deg C
	ripple and noise	(2% of rating) p-p/ (0.20%of rating) rms	

**TABLE 1-2. BOP GENERAL SPECIFICATIONS (Continued)**

SPECIFICATION		RATING/DESCRIPTION	CONDITION
<b>OUTPUT CHARACTERISTICS (Continued)</b>			
Current stabilization in current mode (digital or analog control)	source effect	0.05% of rating	min-max input voltage, 230V a-c reference
	load effect	0.2% of rating	0-100% load voltage
	time effect (drift)	0.02% of rating	0.5 through 8 hours
	temperature effect	0.02% of rating/deg C	0 to 50 deg C
	ripple and noise	(2% of rating) p-p/ (0.20% of rating) rms	
Error sensing		0.25V or 1% of voltage rating per wire (whichever is less)	Above rated output voltage <sup>(5)</sup>
Transient recovery in voltage mode	maximum excursion	5% of nominal output	nominal voltage, 50% load step
	Recovery time	350 μsec	Return within 1% of set voltage
Output isolation voltage	d-c or p-p	300V (500V for BOP 10-100G)	Output to chassis ground
	d-c leakage current	0.1mA @ 300V (0.1mA @ 500V for BOP 10-100G)	GND-NET to GND link not installed. <sup>(6)</sup>
Series operation		Master/slave	Maximum of 3 identical units. <sup>(7)(8)</sup>
Parallel operation		Master/slave	Maximum of 5 identical units <sup>(7)(8)</sup>
Power-up Timing	Series or parallel systems	15 sec. max.	Time required for system to be able to respond to analog or digital control.
Output Protection limiting	Analog	Voltage and current limited in four quadrants, adjustable between 10% and 101% of $E_{ONOM}$ or $I_{ONOM}$	
	Digital	Voltage and current limited in four quadrants, adjustable between $\pm$ Internal minimum $E_{OMIN}$ or $I_{OMIN}$ (box) (see Figure 1-3) and $\pm 1.01 E_{ONOM}$ or $I_{ONOM}$ .	
Output Stage Protection		Output overvoltage/overcurrent Heatsink overtemperature, switchers overcurrent	Triggers latched shutdown protection of the output module and PFC stage. Recover by cycling power off, then on.
Input Stage Protection (PFC)		Internal overvoltage, undervoltage, overcurrent, heat sink overtemperature, fan inoperative	
		Input circuit breaker overcurrent	Trips circuit breaker to shut off unit
Small signal Bandwidth	voltage channel	2 KHz minimum	Into nominal resistive load 10% of rating
	current channel	800 Hz minimum (BOP 6-125G: 600 Hz minimum)	Into short circuit, 10% of rating
Rise/Fall time	voltage channel	300/300 μS	Into nominal resistive load, measured from 10 to 90%, from 0 to $\pm 100\%$ of rating
	current channel	500/500 μS	Into short circuit, measured from 10 to 90%, from 0 to $\pm 100\%$ of rating
External limit channels update rate		100mS max	Voltage or current, positive and negative limit values

(5) Remote error sensing applies to the main voltage channel. Feedback for the  $\pm$ voltage limit channels is supplied locally from the power terminals. Consult factory for a remote sensing solution applicable to the voltage limit channels.

(6) With GND-NET to GND link installed: 0.55mA at 300V (0.91mA at 500V for BOP 10-100G).

(7) Consult factory to configure more than three units in series or parallel (three units for BOP 10-100G in parallel).

(8) For multiple unit configurations, automatic shutdown upon accidental removal of the cable at the Master PAR/SER IN PROTECT PORT can be implemented with a simple internal modification. Consult factory for details.

**TABLE 1-2. BOP GENERAL SPECIFICATIONS (Continued)**

SPECIFICATION	RATING/DESCRIPTION	CONDITION	
<b>PROGRAMMING CHARACTERISTICS</b>			
Analog I/O Port <sup>(9)</sup> (see Table 2-11)	Main channel (voltage or current)	-10V to +10V	Full range output, 20K Ohm input impedance
	Protection Limit channels: +Voltage, -Voltage +Current, -Current	+1V to +10V	10% to 100% of Nominal Range. Input voltage clamped to 12V through 1K ohms. Maximum of 0.15mA input current at 1V input voltage. ±Voltage protection controllable in Current Mode, ±Current protection limits controllable in Voltage mode. Set at 1.01 x nominal rating of main channel for voltage or current.
	Mode control	Voltage: open circuit or TTL logic 1 Current: short circuit or TTL logic 0	Available only when digitally activated or through power-up setting.
	Output current analog readback	-10V to +10V	For -100% to +100% of rating for output current, 2K Ohm output impedance.
External Protection Port (Table 2-5)	External Shutdown	Isolated input for shutdown of the BOP (latched status)	Pulse width: 100 microseconds min. Action delay: 100 microseconds max Restore operation by cycling input power.
	External Shutdown Flag	Isolated output indicating shutdown status	Action delay: 100 microseconds max
	External On-Off Flag or External Trigger	Flag: Isolated output indicating output on (enabled, STANDBY off) or off (disabled, STANDBY on) status)  Trigger: Isolated trigger output for external devices.	Flag: LIST:SET:TRIG enables trigger function. Flag action delay: 200 mS max  Trigger: LIST:CLE disables trigger and restores flag. Trigger output pulse duration: settable between 0.25 to 34mS Trigger output action delay: 100 μS max. Trigger output active level: settable to either "0" or "1."

(9) Main channel can be controlled by either external analog signal or digital remote control. Consult factory if both analog and digital control are required.

**TABLE 1-2. BOP GENERAL SPECIFICATIONS (Continued)**

SPECIFICATION	RATING/DESCRIPTION	CONDITION
<b>PROGRAMMING CHARACTERISTICS (Continued)</b>		
Trigger Port (See Table 2-4) Shutdown (pin 2):	Operation of pin 2 is controlled by OUP:CONT command (see Par. B.15). Settings are LPLS (default), HON, LON, HOFF, LOFF, OFF. Either OFF, LPLS, LOFF or HOFF is required if using OUP ON and OUP OFF commands to control the output. Setting output to off stops a running list.	
LPLS (default)	External Trigger Shutdown (Isolated input. Front panel display shows LowPulse. Logic 0 or short-circuit causes the output to go to STANDBY (off, disabled) (latched status)	Pulse width: 100 $\mu$ S min. Action delay: 200 mS max Restore operation by pressing <b>STANDBY</b> key. or sending OUP ON command via remote interface.
HON	Front panel display shows HighsOn. Isolated Input for controlling output status, on or off. High or open (not connected), output is on (enabled). When 0 volts or short circuit applied to the pin, output is off (disabled)	Pulse width: 6 mS min for any guaranteed unit response. Action delay: 200 mS max
LON	Front panel display shows LowsOn. Isolated Input for controlling output status, on or off. Logic 0 = output is on (enabled); Logic 1 or open (not connected) = output is off (disabled).	Pulse width: 6 mS min for any guaranteed unit response. Action delay: 200 mS max
LOFF	Front panel display shows LowsOff. Isolated Input. When disconnected or open, STANDBY and OUP ON commands will set output on. When low or shorted, output is always off.	Action delay: 200 mS max
HOFF	Front panel display shows HighsOff. Isolated Input. When disconnected or open, output is always off. When low or shorted, STANDBY key and OUP ON commands will set output on.	Action delay: 200 mS max
OFF	Trigger port disabled. Inputs applied to pin 2 have no effect.	
External Trigger Input (pin 4)	Isolated input for trigger events	Pulse width: 100 $\mu$ S min. Action delay: 500 $\mu$ S max
Digital control	remote	IEEE 488-2 (GPIB) and RS 232
	remote	RS 485 (BITBUS)
		SCPI
		IEEE 1118, used for series and parallel configurations
Status Display	front panel	Lights: Unit Status: POWER / FAULT/LIMIT (lights green for Power OK, lights red for Fault, lights orange for Limit). Output Status: OUTPUT ON (lights green On, not lit for Off). Mode of Operation: VOLTAGE/CURRENT (lights green for Voltage, lights yellow for Current). Control: DIGITAL CONTROL (lights green for Digital control, not lit for Analog control). Type: MASTER/SLAVE (lights green for Standalone or Master, lights yellow for Slave).
	remote	Output voltage and current read back on GPIB or RS 232 bus and output current on the analog readback line.



**TABLE 1-2. BOP GENERAL SPECIFICATIONS (Continued)**

SPECIFICATION	RATING/DESCRIPTION	CONDITION
<b>FUNCTION GENERATOR CHARACTERISTICS</b> (See PAR. 3.5.7)		
Maximum number of waveforms	1	Lost when the unit is turned off, must be saved on the host computer)
maximum number of points per basic waveform	3933	
Maximum number of segments or basic waveforms per waveform	126	Or maximum number of points (whichever comes first) <ul style="list-style-type: none"> <li>• The time interval for each segment depends on the type of waveform: period for ramp and square waveforms, period or fraction of period for sine and triangular waveforms and time interval for DC levels</li> <li>• Waveforms that exceed the maximum number of points are not executed and an error message is generated.</li> </ul>
Types of Basic waveforms	Sine (Sinusoidal waveform) Triangle (Triangular waveform) Pos. Ramp (Ramp waveform) Neg. Ramp (Sawtooth waveform) Square (50% Duty Cycle Pulse) Level (DC waveform)	See LIST:CURR:APPLY (PAR. B.56) for current waveforms, or LIST:VOLT:APPLY (PAR. B.81) for voltage waveforms.
Count (Number of repetitions)	Range: 1 to 255 For Count = 0 the waveform is executed indefinitely until stop command is sent	See LIST:COUNt command (PAR. ). When the count is complete or the waveform is stopped using the CURR:MODE FIX command (PAR. B.27) or VOLT:MODE FIX command (PAR. B.96) the output remains at last output value. The BOP can also stop at the end of a cycle by using the CURR:MODE HALT or VOLT:MODE HALT command.
Waveform Parameters	Type: Voltage or Current  Count: number  Initial/Repeating	See LIST:CURR:APPLY (PAR. B.56) for current waveforms, or LIST:VOLT:APPLY (PAR. B.81) for voltage waveforms). <ul style="list-style-type: none"> <li>• Type of waveform, voltage or current, can be selected only for a new waveform and consequently applies to all waveform segments.</li> <li>• All segments except the last may be set to run once (using the LIST:COUN:SKIP command) or per the Count setting.</li> </ul>

**TABLE 1-2. BOP GENERAL SPECIFICATIONS (Continued)**

SPECIFICATION	RATING/DESCRIPTION	CONDITION
<b>FUNCTION GENERATOR CHARACTERISTICS (Continued)</b>		
Basic waveform parameters	<p><b>Sine:</b> Frequency (Hz), Amplitude (Vp-p or Ap-p), Offset (Vd-c or Ad-c), Start Phase (°), Stop Phase (°).</p> <p><b>Triangular:</b> Frequency (Hz), Amplitude (Vp-p or Ap-p), Offset (Vd-c or Ad-c), Start Phase (°), Stop Phase (°).</p> <p><b>Ramp (Pos. or Neg.):</b> Frequency (Hz), Amplitude (Vp-p or Ap-p), Offset (Vd-c or Ad-c).</p> <p><b>Square:</b> Frequency (Hz), Amplitude (Vp-p or Ap-p), Offset (Vd-c or Ad-c).</p> <p><b>Level:</b> Timing (sec), Amplitude (Vd-c or Ad-c).</p> <ul style="list-style-type: none"> <li>The start/stop phases are global parameters, applicable to all sine/ triangular waveform segments. They are independent and can have any value between 0° and 360°.</li> </ul>	
LIST command characteristics for "string" type waveform	<p>Maximum number of points</p> <ul style="list-style-type: none"> <li>For single (global) dwell time: 5900 (high resolution)</li> <li>For &lt;126 different dwell times: 3933</li> <li>For &gt;126 different dwell times: 2950</li> </ul> <p>Dwell time range: 93usec to 34msec.</p> <p>Dwell time resolution (increment): 0.751usec</p> <p>Skip feature (a number of steps can be skipped from the LIST at the first run using LIST:COUN:SKIP.)</p> <p>Able to synchronize a LIST command with multiple BOP's or other devices using Trigger Port (see Table 2-4 NOTE).</p> <p>Able to sample output voltage or current during LIST command execution (see Figures B-2 and B-3).</p>	Note: Dwell time list must match (balance) the amplitude list.
Frequency:		Not applicable to Level
Range (Hz)	0.01 to 443	Sine, Triangle
	0.02 to 532	±Ramp
	0.02 to 1000	Square
Programming Resolution (Hz)	0.01	
Accuracy	1.5% of Frequency	Sine, Triangle, Square, ±Ramp
Period (applicable to Level only)		
Range (Seconds):	0.0005 TO 5.0000	
Resolution:	0.0001	
Accuracy:	1.5% of Time Duration	

**TABLE 1-2. BOP GENERAL SPECIFICATIONS (Continued)**

SPECIFICATION		RATING/DESCRIPTION	CONDITION
<b>FUNCTION GENERATOR CHARACTERISTICS (Continued)</b>			
Amplitude Range			
Main Channel	Voltage (Volts p-p)	0 to 2 x E <sub>ONOM</sub>	Sine, Triangle, Square, ±Ramp
	Current (Amperes p-p)	0 to 2 x I <sub>ONOM</sub>	Sine, Triangle, Square, ±Ramp
Protection Limit Channel .	Current, bipolar (Amperes)	0 to I <sub>ONOM</sub>	(set once for all segments)
	Voltage, bipolar (Volts)	0 to E <sub>ONOM</sub>	
Offset	Voltage (Volts)	-E <sub>ONOM</sub> to +E <sub>ONOM</sub>	Applies to offset of sine, triangle, ±ramp, and square waveforms and to Level waveform Amplitude.
	Current (Amperes)	-I <sub>ONOM</sub> to +I <sub>ONOM</sub>	
Amplitude Resolution (Programming)			
Main Channel and Offset	Voltage (millivolts a-c)	.35	Sine
	(millivolts d-c)	1	Triangle, Square, ±Ramp, Level:
Current (milliamperes a-c)	(millivolts d-c)	.35	Sine
	(millivolts d-c)	1	Triangle, Square, ±Ramp, Level:
Protection Limit Channel .	Current, bipolar (Amperes)	0.1	
	Voltage, bipolar (Volts)	0.1	
Amplitude Accuracy			
Main Channel and Offset	Voltage	0.05% E <sub>ONOM</sub>	
	Current	0.05% I <sub>ONOM</sub>	
Protection Limit Channel .	Current	0.1% I <sub>ONOM</sub>	
	Voltage	0.1% E <sub>ONOM</sub>	
Distortion (THD-F, Total Harmonic Distortion relative to the fundamental component)		5% max.	Sine
		13% max.	Triangle
		70% max.	±Ramp
		47% max.	Square
Start/Stop Angle (Phase)		Range	0 to 360°
		Programming Resolution	0.01°
Accuracy	Start Angle	1°	
	Stop Angle	1° @ 0.01Hz, to 16° @ 443 Hz	Frequency dependent

**TABLE 1-2. BOP GENERAL SPECIFICATIONS (Continued)**

SPECIFICATION		RATING/DESCRIPTION	CONDITION
<b>SAVE/RECALL CHARACTERISTICS</b> (See PAR. 3.5.7)			
Number of Locations		99	15 locations available to be implemented on power-up
Parameters Saved or Recalled			All parameters saved for power-up
	Mode of operation	Voltage, Current or External	For External the operating mode is determined by signal at I/O Port; no signal selects voltage mode (see PAR. 3.4.1).
	Reference type	Internal, External or External Reference Level	Main channel
		Internal, External or Lesser Limit	Limit channel
	Main Amplitude (Internal)	0 to $E_{ONOM}$ or $I_{ONOM}$ (internal or external)	Main Channel: Voltage (Volts) for Voltage mode, Current (Amperes) for Current mode
	Protection Limit Amplitude (Internal)	$E_{OMIN}$ or $I_{OMIN}$ to $1.01 E_{ONOM}$ or $I_{ONOM}$	Limit Channel, Positive and Negative Voltage (Volts) for Current mode, Current (Amperes) for Voltage mode
	Output status	ON or OFF	
<b>MISCELLANEOUS FEATURES</b>			
Digital Maximum/Minimum Settings	Protection Limit Type	Bipolar (default) or Independent	
	Main Channel	0 to $E_{ONOM}$ or $I_{ONOM}$ (default)	Software limit to setting of main channel: Voltage (Volts) for Voltage mode, Current (Amperes) for Current mode.
	Protection Limit Channel (maximum value, Internal)	$E_{OMIN}$ or $I_{OMIN}$ to $1.01 E_{ONOM}$ or $I_{ONOM}$ (internal)	Software limit to setting of protection limit channel: Voltage (Volts) for Current mode Current (Amperes) for Voltage mode
Digital Self-test capabilities		Serial Interface, Analog, Output	Serial Interface test requires Loop Back Test connector
Digital Interface Settings	Data Format	SCPI	
	Output Status @ Reset	ON or OFF (OFF = default)	
	Serial Baud Rate	Off, 9600, 19200 (Off = default)	
	Device Clear	SCPI (default) or MATE	
	XON/XOFF	Enable (default) or Disable	
	Prompt	Disable (default), Enable, Enable with Echo	
Digital Calibration		Computer-assisted through GPIB or RS 232 bus	
Power-up Settings (top cover accessible (see Table 2-2))		Allow the unit at power up to: <ul style="list-style-type: none"> <li>• Set Load type</li> <li>• Set the GPIB address</li> <li>• Set the system configuration for multiple units in series or parallel.</li> <li>• Enable the analog programming input for main channel and for limit channels.</li> <li>• Enable the control signal for the mode of operation, voltage or current.</li> <li>• Set the unit with previously saved custom settings.</li> <li>• Reset the unit to internal factory default settings, after which the desired power-up settings must be configured.</li> </ul>	

**TABLE 1-2. BOP GENERAL SPECIFICATIONS (Continued)**

SPECIFICATION	RATING/DESCRIPTION	CONDITION	
<b>GENERAL (ENVIRONMENTAL) CHARACTERISTICS</b>			
Temperature	operating	0 to +50 deg C	Full rated load
	storage	-20 to +85 deg C	
Cooling	Two internal fans	intake from the front, exhaust to the rear	
Humidity	0 to 95% RH	non-condensing	
Shock	20g, 11msec ±50% half sine	non-operating	
Vibration	5-10HZ:	10mm double amplitude	3 axes, non-operating
	10-55HZ:	2g	3 axes, non-operating
Altitude	sea level to 10,000 feet		
Safety Certification	a-c power	UL 3101-1 and EN 6101-1	Pending
<b>PHYSICAL CHARACTERISTICS</b>			
Dimensions	English	5.25' X 19" X 21.5"	H X W X D
	metric	133.3mm X 482.6mm X 546.1mm	H X W X D
Weight, 1000W models	English	53 lbs	
	metric	24.1Kg	
Connections	Source power	3-pin IEC connector	
	Load connections	Nickel-plated copper bus bars	With 1/4-20 threaded standoff.
	Sensing Output Terminal Block	7-pin terminal block	Default: 3 links installed for local sensing and ground network connected.
	Analog I/O control port	15-pin D female	See Figure 2-1, Table 2-11.
	PAR/SER CTRL IN port	8-pin mini DIN connector	See Figure 2-1, Table 2-8.
	PAR/SER CTRL OUT port	4-pin mini DIN connector	See Figure 2-1, Table 2-7
	PAR/SER PROT IN port	8-pin phone jack	See Figure 2-1, Table 2-9
	PAR/SER PROT OUT port	8-pin phone jack	See Figure 2-1, Table 2-10
	EXT PROT port	6-pin phone jack	See Table 2-5
	Primary digital port	24-pin GPIB connector	IEEE 488 port - See Table 2-12
	Secondary digital ports	6-pin phone jack	RS 232 port - See Table 2-6
5-pin mini DIN female connector		IEEE 1118 port - See Table 2-3	
External Trigger	4-pin stereo audio phone jack	See Table 2-4	
Front Panel Controls and Indicators	Power ON/OFF Circuit Breaker	See Figure 3-1 and Table 3-1	
	Output ON LED		
	Power/Fault/Limit LED		
	Master/Slave LED		
	Voltage/Current LED		
	Digital Control LED		
Top Cover Controls	Power -up Set-up switches (S1, S2, S3)	See Figure 2-2, Table 2-2, PAR's . 3.3.2.1, 3.3.2.2, 2.8.4 and 2.8.5.	

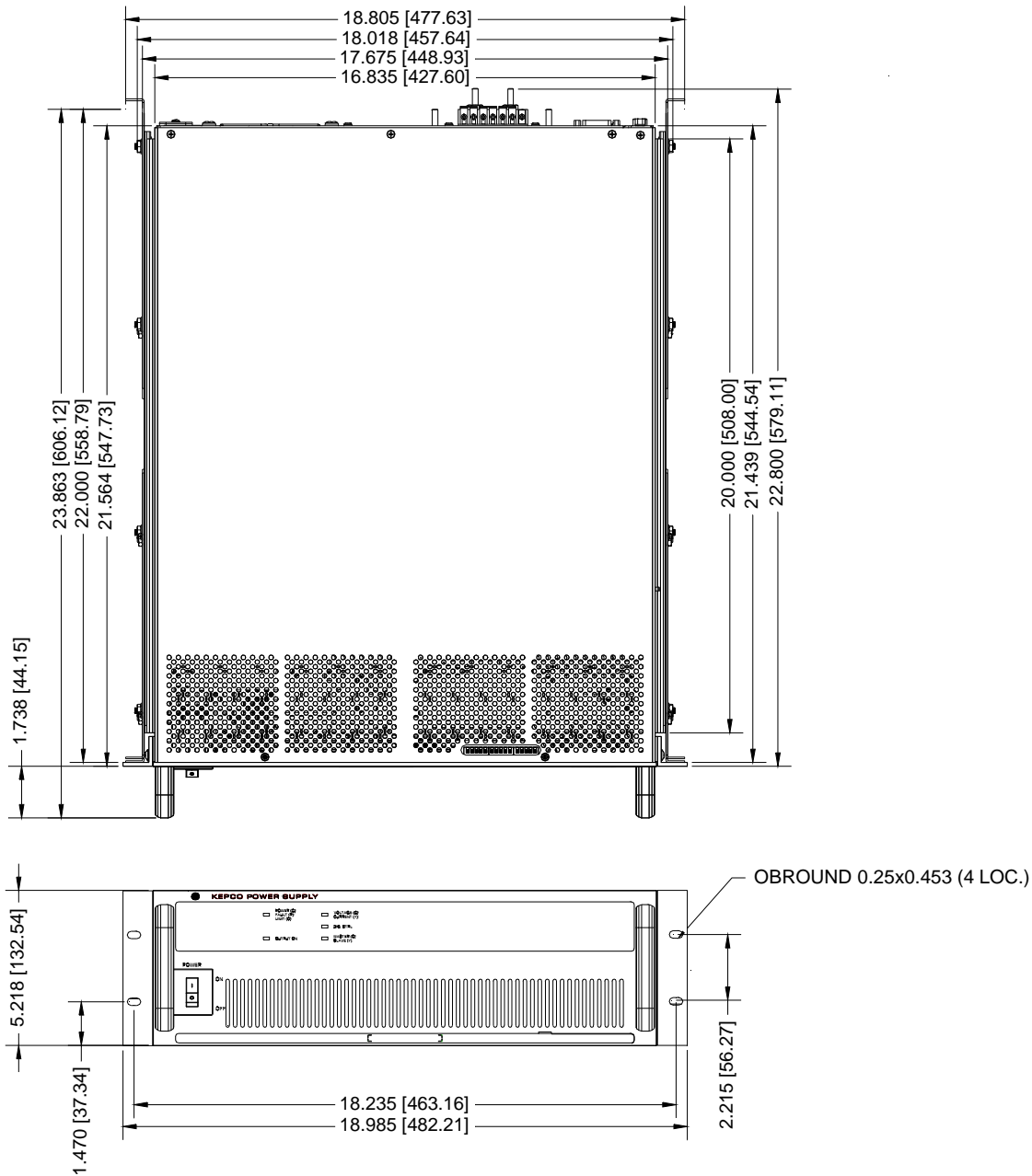

NOTES:

- MATERIAL: A) CHASSIS: #11 GA. C.R.S.  
B) FRONT PANEL: 1/8 THICK 6061-T6 ALUMINUM.  
C) COVER: #16 GA. C.R.S.  
D) BACK PLATE: 0.064 THICK 5052-H32 ALUMINUM.
- FINISH: A) CHASSIS & COVER : CADMIUM PLATE WITH CROMATE WASH.  
B) BACK PLATE: IRIDITE GOLD  
C) FRONT PANEL: SEE 1311145 PAGE 2 OF 3.
- DIMENSION IN PARENTHESSES ARE IN MILLIMETERS.
- TOLERANCES ARE  $\pm 1/32$  (0.8), EXCEPT AS NOTED.
- PRIOR TO INSTALLATION, REMOVE FOUR FEET.
- OPTIONAL SLIDES (KEPCO KIT P/N CS 04) SHOWN INSTALLED.

3043424

**FIGURE 1-2. BOP-G POWER SUPPLY, OUTLINE DRAWING (SHEET 1 OF 2)**

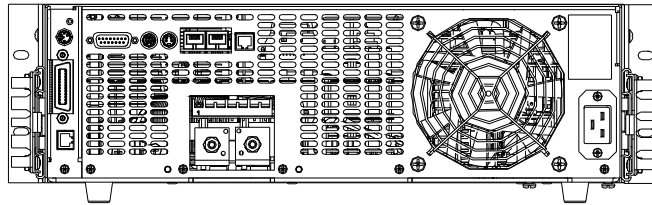

REAR VIEW

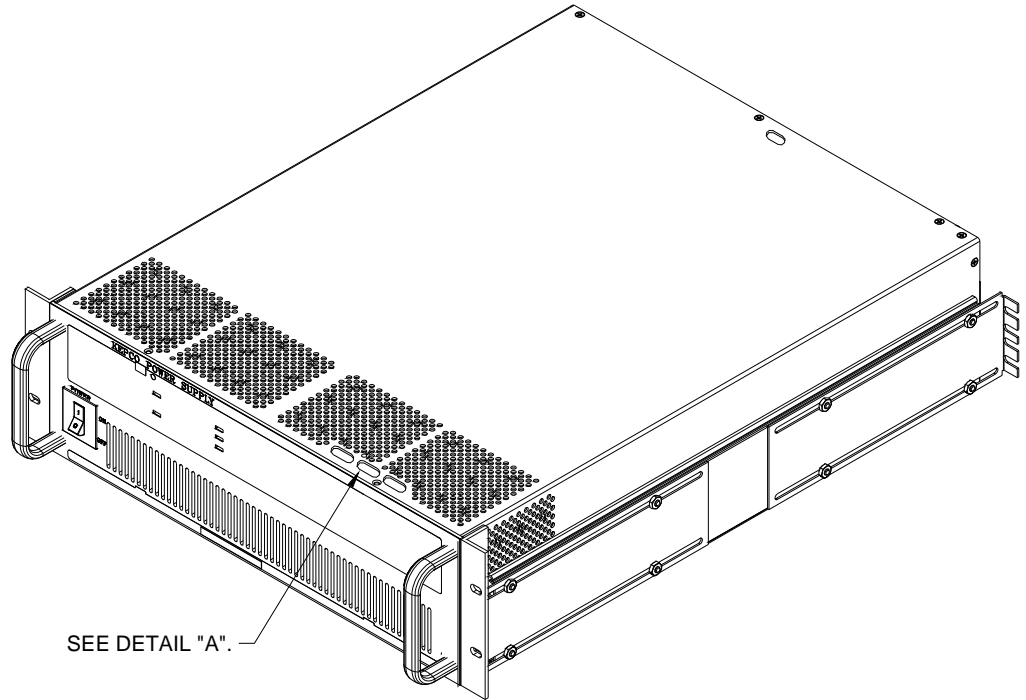

SEE DETAIL "A".

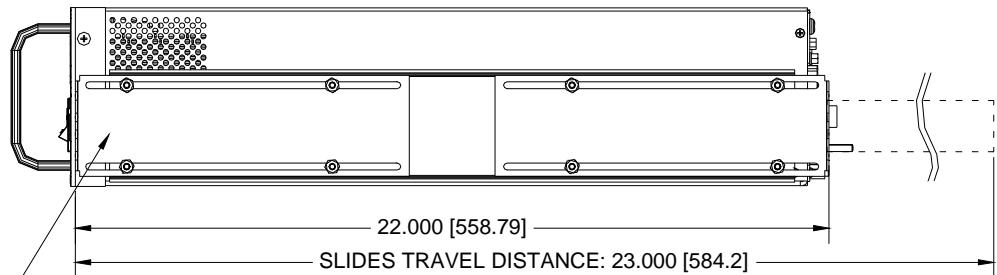

SEE NOTE 6.

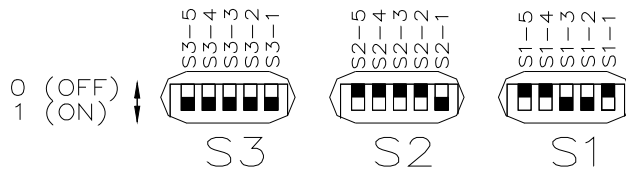

DETAIL "A"

3043424

FIGURE 1-2. BOP-G POWER SUPPLY, OUTLINE DRAWING (SHEET 2 OF 2)

## **1.4 REMOTE CONTROL**

The BOP Power Supply can be remotely controlled directly using either a) analog signal applied to the Analog I/O Port (see PAR. 3.6 for details) or b) digital commands via either the IEEE 488.2 (GPIB) bus (see PARs. 3.6.3) or RS232C interface (see PAR.3.6.4) using IEEE 488 and SCPI commands (see and Appendix A and B, respectively). The unit can be controlled with a VISA (Virtual Instrumentation Software Architecture) driver to facilitate remote programming of the BOP Power Supply (see PAR. 3.6.5). The VISA driver is an interface written in standard C language which adds the proper SCPI syntax to commands sent to the BOP.

The BITBUS is used to allow communication between identical BOP units that are connected in series or parallel to expand the voltage or current range (see PAR. 2.8).

## **1.5 FEATURES**

### **1.5.1 DIGITAL CALIBRATION**

The BOP Power Supply is digitally calibrated except for the zero and full scale settings of the output voltage analog readback signal which are accessed through a cutout at the rear of the top cover and are done manually. Digital calibration is done via the GPIB or RS 232 interface using digital entries and a calibrated DVM, a precision d-c reference voltage source and precision shunt resistor. Previous calibration values are saved and can be restored if desired. The original factory calibration values can also be restored. (Refer to Section 4.)

### **1.5.2 VOLTAGE/CURRENT PROTECTION**

Positive and negative voltage or current protection values can be individually programmed. Refer to PAR. 3.3.4.

### **1.5.3 WAVEFORMS**

The BOP models have the capability to make the output follow complex waveforms. These may be generated either using an analog reference voltage having the desired shape (see PAR. 1.5.6), or digitally using SCPI commands (see PAR. 3.5.7).

Digitally, the waveforms can be generated by specifying individual points in the waveform or through the use of standard waveform segments. The segments provided by the BOP are, levels, positive and negative ramps, sine waves and triangle waves. While executing a waveform, it is possible to cause other devices to be triggered by the BOP and for the BOP to wait for a trigger from another device. Segments or a series of points at the beginning of the waveform can be programmed to be executed only once, or to be repeated as specified by the count. This feature provides unique versatility for generating preconditions, resulting in a waveform that can meet a variety of user requirements.

### **1.5.4 SAVING AND RECALLING SETTINGS**

The BOP offers 99 memory locations that can be used to store a set of operating parameters for later use. For each location, the user can store operating mode, output on/off, Main channel reference type and value, and protection reference type and value. The stored settings can then be recalled to quickly program the unit to the predetermined setting. The settings stored in one of the locations (1 to 15 only) can be programmed to be restored automatically upon power-up using switch S3 (see Table. 2-2). Refer to PAR. 3.5.7 for further details.



### **1.5.5 EXTERNAL REFERENCE (ANALOG CONTROL)**

An external reference, provided through the rear I/O analog port connector (see Table 2-11), can be used to control the output of the BOP. The external reference can be attenuated by the digital controls (see PAR. 3.4.1.2) so the unit operates with a lower amplification factor. In addition, the BOP can limit its output based on the user-configurable limits so that, in the event of a failure in the external reference, the devices connected to the output are protected. Refer to PAR. 3.3.9 for further details on using external signals to control the output.

### **1.5.6 EXTERNAL LIMITS**

When the unit is controlled by an external reference, the protection limits can also be controlled by analog signals that are digitally calibrated. The BOP samples the limit channel inputs and applies the proper limit levels at variable rate (5 to 100 milliseconds), alternately sampling the positive and negative limits. The external limit inputs are hardware-protected against overvoltage. Refer to PAR. 3.4.2

### **1.5.7 USER-DEFINED VOLTAGE/CURRENT MAXIMUM VALUES (SOFTWARE LIMITS)**

The BOP output can be programmed not to exceed user-defined values. For example, the BOP 36-28G, which has a maximum capacity of  $\pm 36\text{V}$ ,  $\pm 28\text{A}$ , can be limited to  $+30\text{V}$ ,  $-10\text{V}$ ,  $+5\text{A}$ ,  $-1\text{A}$  for working with circuitry that might be damaged by higher levels. Once the limits are set, values exceeding the limit values will not be accepted, including external references and protection limits. Refer to PAR. 3.3.5.1.

### **1.5.8 PARALLEL AND SERIES CONFIGURATIONS**

Identical BOP units may be configured in series or parallel. If a series or parallel configuration is enabled, communication between the master BOP and those configured as slave units occurs via the BITBUS. Refer to PAR. 2.8 for further details.

### **1.5.9 ENERGY RECUPERATION**

The BOP is a four-quadrant device as shown in Figure 1-3. Operating as a source, it delivers energy into a passive load, and as a sink it operates as an electronic load, absorbing and dissipating energy from an active load. To minimize energy dissipation, the BOP employs energy recuperation, where energy sunk from an active load is passed backwards through the output circuit and the bidirectional input power factor correcting circuit to the a-c power lines, where it becomes available for general reuse. This technology allows high power levels using switch-mode technology while maintaining high efficiency and reduced size and weight.

## 1.6 EQUIPMENT SUPPLIED

Equipment supplied with the BOP power supply is listed in Table 1-3.

**TABLE 1-3. EQUIPMENT SUPPLIED**

ITEM	FUNCTION	PART NUMBER
Source Power Entry mating connector	Mates with source power entry connector	142-0381 (Kepco) (IEC 320)
PAR/SER CONTROL - IN mating connector	Mates with PAR/SER CONTROL - IN port to allow access to pins required for calibration	142-0488 (Kepco)
Mating Connector, Trigger	Mates with Trigger port.	142-0527 (Kepco) SP2501 (CUI Stack)
Mating Connector, Analog I/O Port (15-pin DSUB Connector)	Mates with connector for Analog I/O port A2A5J6 Dsub 15 pin hood Dsub 15 pin male	108-0374 (Tyco-Amp 207470-1) 142-0449 (Amphenol 17S-DA15P)



## 1.7 ACCESSORIES

Accessories for the BOP Power Supply are listed in Table 1-5.

## 1.8 SAFETY

Service must be referred to authorized personnel. Using the power supply in a manner not specified by Kepco, Inc. may impair the protection provided by the power supply. Observe all safety precautions noted throughout this manual (see listing on page D, preceding the Table of Contents). Table 1-4 lists symbols used on the power supply or in this manual where applicable.

**TABLE 1-4. SAFETY SYMBOLS**

SYMBOL	Meaning
	WARNING! RISK OF ELECTRIC SHOCK!
	CAUTION: REFER TO REFERENCED PROCEDURE.
WARNING	INDICATES THE POSSIBILITY OF BODILY INJURY OR DEATH.
CAUTION	INDICATES THE POSSIBILITY OF EQUIPMENT DAMAGE.

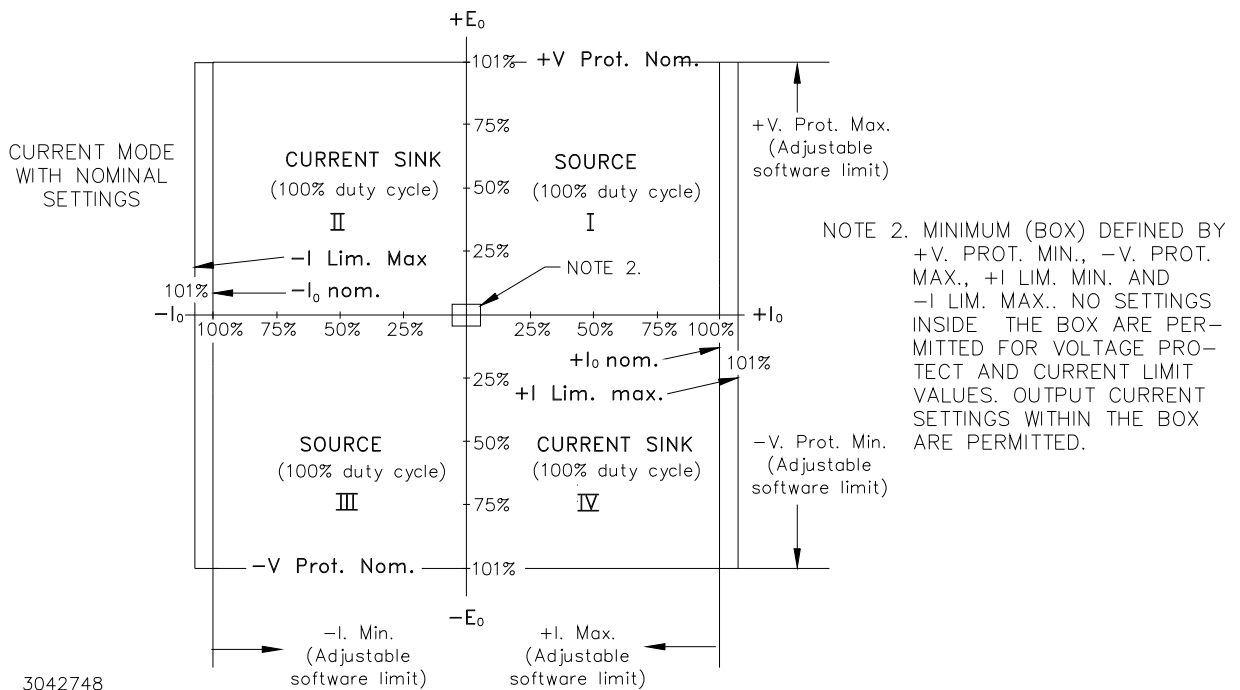
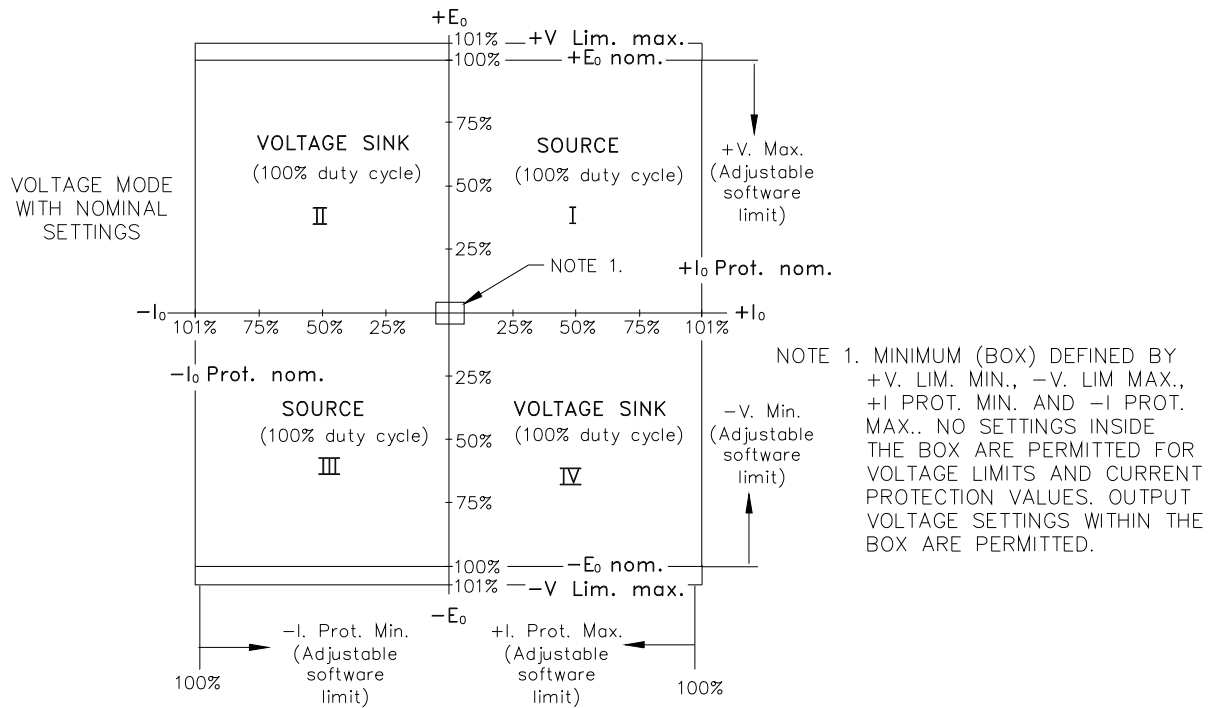

3042748

FIGURE 1-3. BOP OUTPUT CHARACTERISTICS

**TABLE 1-5. ACCESSORIES**

ITEM	FUNCTION	PART NUMBER
Mating Connector, Trigger	Mates with Trigger port.	142-0527 (Kepco) SP2501 (CUI Stack)
IEEE 1118 (BITBUS) Mating connector	Allows connection to IEEE 1118 (BITBUS) port.	142-0485 (Kepco) KMDLA-5P (Kycon Inc.)
IEEE 488 Cable, (1 meter long)	Connects BOP power supply to GPIB bus.	SNC 488-1
IEEE 488 Cable, (2 meter long)	Connects BOP power supply to GPIB bus.	SNC 488-2
IEEE 488 Cable, (4 meter long)	Connects BOP power supply to GPIB bus.	SNC 488-4
Interconnection Kit for multiple identical power supplies in parallel (increase output current)	Cables required to connect multiple BOP models in parallel for increased current capability, e.g., connecting two BOP 10-75G models in parallel to produce a virtual BOP 10-150G.	KIT 219-0449 (2 in parallel) KIT 219-0446 <sup>(1)</sup> (3 in parallel) KIT 219-0447 <sup>(1)</sup> (4 in parallel) KIT 219-0448 <sup>(1)</sup> (5 in parallel)
Interconnection Kit for multiple identical power supplies in series (increase output voltage)	Cables required to connect multiple BOP models in series for increased voltage capability, e.g., connecting two BOP 10-75G models in series to produce a virtual BOP 20-75G.	KIT 219-0443 (2 in series) KIT 219-0444 <sup>(1)</sup> (3 in series)
Line Cord (250V, 20A)	Provides connection to a-c mains via Nema 6-20P connector.	118-1087
Line Cord (250V, 20A)	Provides connection to a-c mains via Nema L6-20P locking type connector.	118-1088
RS 232 Cable Kit	Contains RJ11 to RJ45 Patch cord, RJ 45 Patch cord, two RS 232 adapters, one with male pins to connect to DTE equipment and one with female pins to connect to a PC (personal computer), two RS 232 Loop Back test Connectors (one 6-pin and one 8-pin) to test RS 232 communication and aid in isolating RS 232 communication problems.	KIT 219-0436
RS 232 Adapter (Male pins)	Allows RS 232 port to be connected to DTE equipment. (Supplied in KIT 219-0436.)	142-0487 (L-COM RA098M)
RS 232 Adapter (Female pins)	Allows RS 232 port to be connected to a PC (personal computer). (Supplied in KIT 219-0436.)	142-0506 (L-COM RA098F)
15-pin DSUB Connector	Mating connector for Analog input connector A2A5J6 Dsub 15 pin hood Dsub 15 pin male	108-0374 (Tyco-Amp 207470-1) 142-0449 (Amphenol 17S-DA15P)
IDC 6-pin connector	Mating connector for RS-232 PORT, connector A1J5 and PROTECT EXT. PORT, connector A2A5J7	142-0536 (Amphenol 5-555176-3)
IDC 8-pin plug	Mating connector for PAR/SER PROTECT PORT (IN and OUT) connectors.	142-0535 (Amphenol 5-557961-2)
Slides	Allows easy withdrawal of unit from rack (see Figure 1-2). (Model CS 04 includes slides, brackets, all mounting hardware and installation instructions.)	CS 04
Heat Sink	Provides adequate cooling for calibration sense resistors.	136-0451
Terminal Cover	Protects against contact with output and barrier strip terminals. Install using the two existing screws (adjacent to two ground terminals) securing rear panel to chassis. Particularly recommended for 72V and 100V models for safety purposes. Consult factory for parallel/series configurations.	129-0423

(1) Consult factory for configurations requiring more than two units in parallel or series

## SECTION 2 - INSTALLATION

### 2.1 UNPACKING AND INSPECTION

This instrument has been thoroughly inspected and tested prior to packing and is ready for operation. After careful unpacking, inspect for shipping damage before attempting to operate. Perform the preliminary operational check as outlined in PAR. 2.3. If any indication of damage is found, file an immediate claim with the responsible transport service.

### 2.2 TERMINATIONS AND CONTROLS

- a) Front Panel: Refer to Figure 3-1 and Table 3-1.
- b) Rear Panel: Refer to Figure 2-1 and Table 2-1.
- c) Top Cover: Refer to Figure 2-2 and Table 2-2.

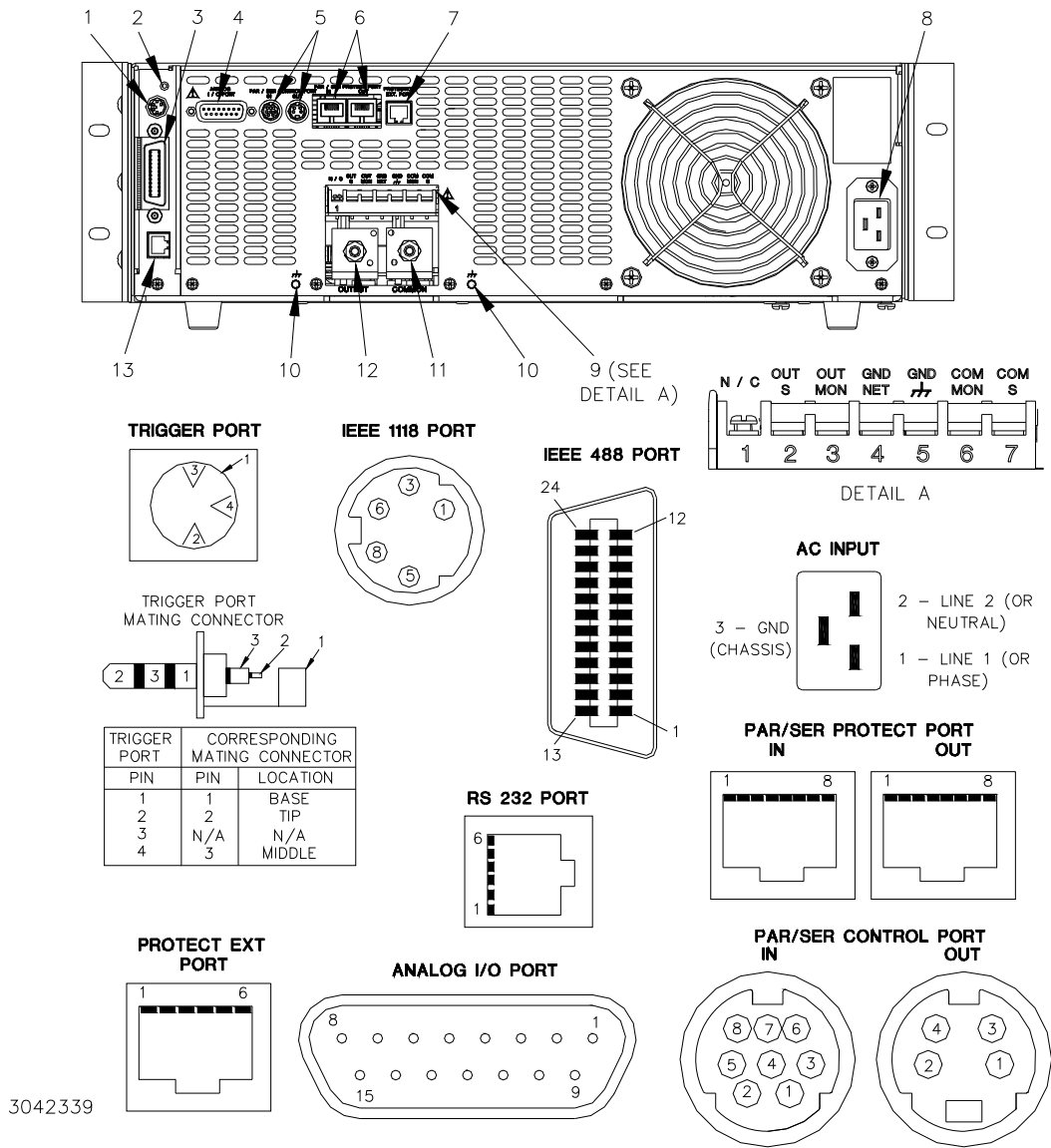

**FIGURE 2-1. BOP-G SERIES REAR PANEL**

**TABLE 2-1. REAR PANEL CONNECTOR FUNCTIONS**

NUMBER (FIGURE 2-1)	CONNECTOR/TERMINAL (REFERENCE DESIGNATOR)	FUNCTION
1	IEEE 1118 (BITBUS) PORT <sup>(1)</sup> (connector A1J4)	Used for multiple identical BOP master/slave parallel, and series and series-parallel configurations (see Table 2-3).
2	TRIGGER (connector A1J3)	May be used to initiate BOP output. (See Table 2-4.)
3	IEEE 488 (GPIB) PORT (connector A1J6)	Used for Remote control of the BOP via the IEEE 488 (GPIB) interface (See Table 2-12.)
4	ANALOG I/O PORT (connector A2A5J6)	Provides interface for analog input/output signals. (See Table 2-11.)
5	PARALLEL/SERIAL CONTROL PORT (connectors A2A5J3, IN and A2A5J4, OUT)	Provides interconnections used to control parallel or serial configurations of identical BOP's as a single power supply (see Table 2-8 for A2A5J3, IN and Table 2-7 for A2A5J4, OUT).
6	PARALLEL/SERIAL PROTECT PORT (connectors A2A5J1, IN and A2A5J2 OUT)	Provides interconnections used to control protection shutdown of power supplies connected in parallel or serial configurations (see Table 2-9 for A2A5J1, IN and Table 2-10 for A2A5J2, OUT).
7	EXT PROTECT PORT (connector A2A5J7)	Provides means for controlling protection via external circuitry and provides status flags to external circuitry. (See Table 2-5.)
8	INPUT connector (connector A7J1)	Connects source power to unit. Pin 1 - Line (or Line 1 without Neutral connection) Pin 2 - Neutral (or Line 2 without Neutral connection) Pin 3 - Ground (Protective conductor terminal)
9	Monitor and Sensing terminal block (terminal block A7A1TB1)	Terminal block provides external connections as follows: OUT S: Sense line connection to load (compensate for voltage drop on connections to load.) (Terminal 2). OUT MON: Monitor connection used to monitor output voltage at power terminals and to implement local sensing (Terminal 3). GND NET: Grounding network connection (Terminal 4). GND: Chassis ground connection (Terminal 5). COM MON: Monitor return connection (Terminal 6). Used to monitor output voltage at power terminals and to implement local sensing. COM S: Sense line return connection from load (Terminal 7)
10	 terminals	Frame or chassis terminals
11	COMMON (terminal A7J3)	Power output return from load.
12	OUTPUT (terminal A7J2)	Power output connection to load.
13	RS232 PORT (connector A1J5)	Used for Remote control of the BOP via the RS 232 serial interface. (See Table 2-6 for details.)

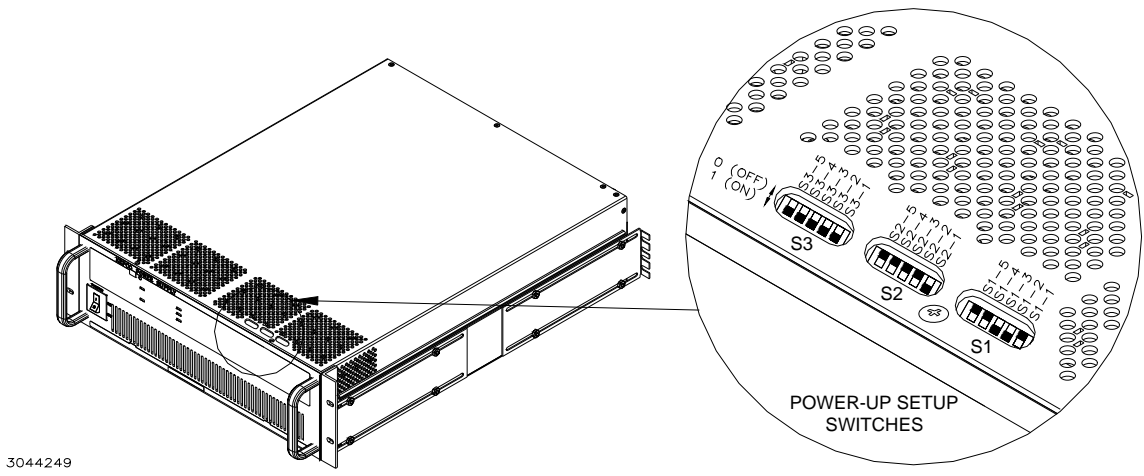

3044249

**FIGURE 2-2. BOP-G TOP COVER ACCESSIBLE COMPONENTS**

**TABLE 2-2. POWER-UP SETUP SWITCHES**

SWITCH (FIGURE 2-2)	SECTION	FUNCTION	DESCRIPTION																																		
S1	S1-1	Bit 1 (LSB)	1. Enable the GPIB address from 0 [00000] to 30 [11110] while reading power-up switches S2 and S3 during a normal power-up (see PAR. 3.3.2.2 for details). 2. Address 31 (11111) initiates a special power-up reset which resets the limits to factory defaults (see PAR. B.145), allows selection of Load type, allows selection of Remote on-off logic at Trigger port pin 2 and selection of RS 232 baud rate. (see PAR. 3.3.2.1 for details)																																		
	S1-2	Bit 2																																			
	S1-3	Bit 3																																			
	S1-4	Bit 4																																			
	S1-5	Bit 5 (MSB)																																			
S2	S2-1	Master or Standalone (1) Slave (0)	Establish whether the unit is standalone or designated as master or slave in a multiunit series or parallel configuration																																		
	S2-2	Series (1) Parallel (0)																																			
	S2-3	Bit 1 (LSB) (see Table at right)																																			
	S2-4	Bit 2 (see Table at right)																																			
	S2-5	Bit 3 (see Table at right)																																			
	<table border="1"> <thead> <tr> <th>S2-5</th> <th>S2-4</th> <th>S2-3 (LSB)</th> <th colspan="2">Configure unit as</th> </tr> <tr> <td></td> <td></td> <td></td> <th>S2-1 = 1</th> <th>S2-1 = 0</th> </tr> </thead> <tbody> <tr> <td>0</td> <td>0</td> <td>0</td> <td>Standalone</td> <td>N/A</td> </tr> <tr> <td>0</td> <td>0</td> <td>1</td> <td>Master with 1 slave</td> <td>Slave #1</td> </tr> <tr> <td>0</td> <td>1</td> <td>0</td> <td>Master with 2 slaves (1)</td> <td>Slave #2 (1)</td> </tr> <tr> <td>0</td> <td>1</td> <td>1</td> <td>Master with 3 slaves (1)</td> <td>Slave #3 (1)</td> </tr> <tr> <td>1</td> <td>0</td> <td>0</td> <td>Master with 4 slaves (1)</td> <td>Slave #4 (1)</td> </tr> </tbody> </table>			S2-5	S2-4	S2-3 (LSB)	Configure unit as					S2-1 = 1	S2-1 = 0	0	0	0	Standalone	N/A	0	0	1	Master with 1 slave	Slave #1	0	1	0	Master with 2 slaves (1)	Slave #2 (1)	0	1	1	Master with 3 slaves (1)	Slave #3 (1)	1	0	0	Master with 4 slaves (1)
S2-5	S2-4	S2-3 (LSB)	Configure unit as																																		
			S2-1 = 1	S2-1 = 0																																	
0	0	0	Standalone	N/A																																	
0	0	1	Master with 1 slave	Slave #1																																	
0	1	0	Master with 2 slaves (1)	Slave #2 (1)																																	
0	1	1	Master with 3 slaves (1)	Slave #3 (1)																																	
1	0	0	Master with 4 slaves (1)	Slave #4 (1)																																	
NOTE: the unit will beep if the above switches are set to 110 or 111 (invalid setting). The unit will not beep if the switches are set to 010, 011, 100, or 101 (2, 3, 4, or 5 slaves).																																					

(1) Consult factory to implement configurations of more than one slave.

**TABLE 2-2. POWER-UP SETUP SWITCHES (CONTINUED)**

SWITCH (FIGURE 2-2)	SECTION	FUNCTION	DESCRIPTION															
S3	S3-1 (LSB)	Function established by S3-5	<p>S3-5 determines the function of S3-1 through S3-4:</p> <p>S3-5 = 1: S3-1: Voltage mode (1) or Current mode (0)                      S3-2: Analog Input ON (1) or Analog Input OFF (0) Analog input ON enables pin 11 of the I/O port.                      S3-3 and S3-4 determine limits upon power-up:</p> <table border="1"> <thead> <tr> <th>S3-4</th> <th>S3-3</th> <th>Description</th> </tr> </thead> <tbody> <tr> <td>0</td> <td>0</td> <td>Analog External Protection limits enabled (see PAR. 3.4.2)</td> </tr> <tr> <td>0</td> <td>1</td> <td>Digital -V and -C Prot Max (Internal) set to max. +V and +C Protect Max (Internal) set to min. (box).</td> </tr> <tr> <td>1</td> <td>0</td> <td>Digital +V and +C Prot Max (Internal) set to max. -V and -C Prot Max (Internal) set to min. (box).</td> </tr> <tr> <td>1</td> <td>1</td> <td>Digital ±V Prot Max and ±C Prot Max (Internal) set to max.</td> </tr> </tbody> </table>	S3-4	S3-3	Description	0	0	Analog External Protection limits enabled (see PAR. 3.4.2)	0	1	Digital -V and -C Prot Max (Internal) set to max. +V and +C Protect Max (Internal) set to min. (box).	1	0	Digital +V and +C Prot Max (Internal) set to max. -V and -C Prot Max (Internal) set to min. (box).	1	1	Digital ±V Prot Max and ±C Prot Max (Internal) set to max.
	S3-4			S3-3	Description													
	0			0	Analog External Protection limits enabled (see PAR. 3.4.2)													
	0			1	Digital -V and -C Prot Max (Internal) set to max. +V and +C Protect Max (Internal) set to min. (box).													
	1	0	Digital +V and +C Prot Max (Internal) set to max. -V and -C Prot Max (Internal) set to min. (box).															
	1	1	Digital ±V Prot Max and ±C Prot Max (Internal) set to max.															
S3-2																		
S3-3																		
S3-4 (MSB)																		
S3-5	Establish function of S3-1 through S3-4	<p>S3-5 = 0: Setting S3-4 (MSB) through S3-1 (LSB) to 0 (off) [0000] establishes a special analog control configuration upon power-up: Analog Input ON (main channel reference, pin 11 of Analog I/O port enabled), limit channel references (pins 5, 6, 13 and 14 of Analog I/O port) enabled and pin 2 of Analog I/O port enabled (1 or open = voltage mode, 0 or short = current mode).</p> <p>Setting S3-4 (MSB) through S3-1 (LSB) to 1 [0001] to 15 [1111], restores custom configuration previously saved in selected location 1 to 15. (See PAR. 3.5.7)</p>																

**TABLE 2-3. IEEE 1118 CONNECTOR INPUT/OUTPUT PIN ASSIGNMENTS**

CONNECTOR	PIN	SIGNAL NAME	FUNCTION
IEEE 1118 (BITBUS) PORT (connector A1J4)	1, 3 (shorted)	CONTROL BUS "A"	IEEE 1118, referenced to pins 5, 8 (2-Wire Differential Interface)
	5, 8 (shorted)	CONTROL BUS "B"	IEEE 1118, referenced to pins 1, 3 (2-Wire Differential Interface)
	6	TERMINATOR	Connect to pin 5 or 8 to add an internal termination resistor to first/last unit on the daisy chain.



**TABLE 2-4. TRIGGER PORT PIN ASSIGNMENTS**

CONNECTOR	PIN	SIGNAL NAME	FUNCTION
TRIGGER PORT (connector A1J3)	1	LOGIC GND	Return for EXT TRIGGER and REMOTE ON-OFF signals.
	2	REMOTE ON-OFF	Logic 0 or short-circuit referenced to logic GND (pin 1) sets the output OFF (output disabled). Logic 1 (TTL or 5V-CMOS) or open sets the output to ON (output enabled). This logic can be reversed (see 3.3.2.1 for details.).  When using digital control this pin can also be a) disabled to allow OUTP ON and OUTP OFF to control the output or b) configured to put the unit in standby (see PAR. B.15). Logic 0 or short circuit for at least 100µsec disables the output and puts the unit in standby, however Logic 1 (TTL or 5V CMOS level) does NOT enable the output. A remote OUTP ON command must be used to enable the output. Response to this signal is relatively slow (200mS max).
	3	NOT USED	
	4	EXT. TRIGGER INPUT	Logic 0 for at least 100µsec or short-circuit referenced to logic GND (pin 1) causes a trigger event. Logic 1 (TTL or 5V CMOS level) rearms the trigger feature. Response time is 500µsec max.

**TABLE 2-5. EXTERNAL PROTECTION CONNECTOR INPUT/OUTPUT PIN ASSIGNMENTS**

CONNECTOR	PIN	SIGNAL NAME	FUNCTION
EXT. PROTECT PORT (connector A2A5J7)	1	SD_EXT_K	Cathode of LED optocoupler (through a 510 ohm resistor) which is used for external isolated shutdown. Anode of LED is connected to (A2A5J7) pin 2. A positive voltage (3.5 to 15V) at pin 2 (referenced to pin 1) shuts down the unit. This signal shuts down unit functionality. The unit remains powered, but no output is available and the front panel POWER/FAULTLIMIT LED will turn red. Response is relatively fast (100µS max.). To resume normal operation it is necessary to cycle power off, then on.
	2	SD_EXT_A	Anode of LED optocoupler which is used for external isolated shutdown. (See pin 1 above.)
	3	PG_EXT_C	Collector of optocoupler-transistor which is used for external isolated "power OK" flag. Transistor emitter is connected to (A2A5J7) pin 4. When unit is operating normally, transistor is saturated. Current through transistor should not exceed 5mA and supply voltage should not exceed 15V.
	4	PG_EXT_E	Emitter of optocoupler-transistor which is used for external isolated "power OK" flag. (See pin 3 above.)
	5	EXT_C	Collector of optocoupler-transistor which is used for external isolated "Output OFF" flag. Transistor emitter is connected to (A2A5J7) pin 6. When output is OFF, transistor is saturated. Current through transistor should not exceed 3mA and supply voltage should not exceed 15V. See NOTE below for alternate function.
	6	EXT_E	Emitter of optocoupler-transistor which is used for external isolated "output OFF" flag. (See pin 5 above.)
NOTE: Upon receipt of LIST:SET:TRIG command (PAR B.74), the Output Off flag (EXT_C/EXT_E) no longer represents output on/off state. Instead, this signal can be used to trigger an external device. The transistor state (conducting or not conducting) and the pulse width duration is controlled by the LIST:SET:TRIG command. Upon receipt of LIST:CLE command (PAR B.49) the Output Off flag reverts to representing output on/off status as described above.			

**TABLE 2-6. RS232C PORT INPUT/OUTPUT PIN ASSIGNMENTS**

CONNECTOR	PIN	SIGNAL NAME	FUNCTION
RS 232 PORT A1J5	1	RTS	Request To Send (protocol not used)
	2	RXD	Receive Data
	3	TXD	Transmit Data
	4	LOGIC GND	Logic Ground
	5	LOGIC GND	Logic Ground
	6	CTS	Clear To Send (protocol not used)

**TABLE 2-7. PARALLEL/SERIAL CONTROL OUT PORT PIN ASSIGNMENTS**

CONNECTOR	PIN	SIGNAL NAME	FUNCTION
PARALLEL/SERIAL CONTROL OUT PORT (A2A5J4)	1	SGND	Local signal ground
	2	No connection	
	3	S_IN_PARALLEL	Relayed signal for daisy chain connection. (See PARALLEL/SERIAL IN PORT (A2A5J3) pin 3)
	4	No connection	

**TABLE 2-8. PARALLEL/SERIAL CONTROL IN PORT PIN ASSIGNMENTS**

CONNECTOR	PIN	SIGNAL NAME	FUNCTION
PARALLEL/SERIAL CONTROL IN PORT (A2A5J3)	1	SGND	Local signal ground
	2	No connection	
	3	S_IN_PARALLEL	Input for programming output current of a parallel-connected slave. Provided by master unit. Level: -10V to +10V controls the current between $-I_{Onom}$ to $+I_{Onom}$ .
	4	No connection	
	5	No connection	
	6	IOUT_M_UNIT	Output for programming slave current when the unit is a parallel-connected master Level: -10V to +10V programs slave current to $-I_{Onom}$ to $+I_{Onom}$ .
	7	No connection	
	8	S_IN_SERIAL	Input for programming output voltage of a series-connected slave. Provided by master unit or from previous slave if multiple slaves connected. Level: $-E_{Onom}$ to $+E_{Onom}$ controls programs output voltage from $+E_{Onom}$ to $-E_{Onom}$ .

**TABLE 2-9. PARALLEL/SERIAL PROTECT IN PORT PIN ASSIGNMENTS**

CONNECTOR	PIN	SIGNAL NAME	FUNCTION
PARALLEL/SERIAL PROTECT IN PORT (A2A5J1)	1	SD_A	Anode of LED optocoupler which is part of protection circuit for parallel or series combination. Cathode of LED is connected to PARALLEL/SERIAL PROTECT OUT PORT (A2A5J2) pin 1 (see Table 2-10). When activated, the optocoupler shuts down the unit. LEDs from all units of the parallel or series combination are connected in series.
	2	PGOUT_C	Collector of optocoupler transistor which is part of protection circuit for parallel or series combination. Transistor emitter is connected to PARALLEL/SERIAL PROTECT OUT PORT (A2A5J2) pin 2 (see Table 2-10). When unit is operating normally, transistor is saturated. Transistors from all units of the parallel or series combination are connected in series.
	3	SD_RETURN	Completes return connection for the protection circuit which receives energy from the master unit.
	4	No connection	
	5	No connection	
	6	No connection	
	7	GND	Local power ground.
	8	ALLOW EXT_ERR	Provides energy for the protection circuit (master unit only). Disabled at power up to prevent shutdown during power up.

**TABLE 2-10. PARALLEL/SERIAL PROTECT OUT PORT PIN ASSIGNMENTS**

CONNECTOR	PIN	SIGNAL NAME	FUNCTION
PARALLEL/SERIAL PROTECT OUT PORT (A2A5J2)	1	SD_K	Cathode of LED optocoupler which is part of protection circuit for parallel or series combination. (See IN port (A2A5J1) pin 1, Table 2-9.)
	2	PGOUT_E	Emitter of optocoupler transistor which is part of protection circuit for parallel or series combination. (See IN port (A2A5J1) pin 2, Table 2-9.)
	3	SD_RETURN	Relayed connection, provides return for the protection circuit which receives energy from the master unit.
	4	No connection	
	5	No connection	
	6	No connection	
	7	No connection	
	8	No connection	

**TABLE 2-11. ANALOG I/O PORT INPUT/OUTPUT PIN ASSIGNMENTS**

CONNECTOR	PIN	SIGNAL NAME	FUNCTION
ANALOG I/O PORT A2A5J6	<b>CAUTION: it is recommended that source power of external equipment connected to the Analog Port be applied through an isolating transformer to avoid ground loops or possible damage to the BOP due to incorrect equipment a-c wiring (e.g., defeating of ground connection).</b>		
	1	NC	
	2	VM-/CM	External input signal, TTL logic referenced to pin 9, controls the mode of operation when using external reference (goes to the digital board that changes VM-/CM signal). Logic 0 (or pin grounded) = current mode, logic 1 (or pin not connected, the default) = voltage mode (see PAR. 3.4.1).
	3	IOUT_DMM	Output analog signal referenced to pin 4 for monitoring output current, 0V to ± 10V corresponds to zero to ± full scale current.
	4	SGND	Signal Ground used for IOUT_DMM (pin 3) and VOUT_DMM (pin 15) return.
	5	- I_LIM_EXT	Analog input signal referenced to pin 12, 0V to +10V sets the negative current limit between zero and $-I_{Omax}$ , +10V corresponds to rated maximum current (e.g., for BOP 36-28G +10V sets negative current limit to -28A) (see PAR. 3.4.2). Open = disabled (see NOTE).
	6	- V_LIM_EXT	Analog input signal, 0V to +10V, sets the negative voltage limit between zero and $-E_{Omax}$ , +10V corresponds to rated maximum voltage (e.g., for BOP 36-28G +10V sets negative voltage limit to -36V). Open = disabled. (See PAR. 3.4.2.) Open = disabled (see NOTE).
	7	NC	
	8	NC	
	9	GND	Ground - Used for VM-/CM (pin 2) return
	10	SGND	Signal Ground (used for EXT_REF (pin 11) return
	11	EXT_REF	External analog reference signal referenced to pin 10, used for main channel (either voltage mode or current mode) to control BOP output voltage or current. 0V to ±10V corresponds to zero to ± rated nominal (full scale), voltage or current (see PAR. 3.4.1).
	12	GND1	Ground (Used for pin 5, 6, 13 and 14 return)
	13	+I_LIM_EXT	Analog input signal referenced to pin 12, 0V to +10V sets the positive current limit between zero and $I_{Omax}$ ; +10V corresponds to rated maximum current (e.g., for BOP 36-28G +10V sets positive current limit to +28A) (see PAR. 3.4.2). Open = disabled (see NOTE).
	14	+V_LIM_EXT	Analog input signal, 0V to +10V sets the positive voltage limit between zero and $E_{Omax}$ , +10V corresponds to rated maximum voltage (e.g., for BOP 36-28G +10V sets positive current limit to +36V). Open = disabled. (See PAR. 3.4.2.) (see NOTE).
15	VOUT_DMM	Analog output signal referenced to pin 4 for monitoring output voltage. 0V to ±10V corresponds to zero to ± full scale voltage (5mA max. load),	
NOTE: When disabled, the external limit channels are automatically set 20% higher than BOP nominal references.			

**TABLE 2-12. IEEE 488 PORT INPUT/OUTPUT PIN ASSIGNMENTS**

CONNECTOR	PIN	SIGNAL NAME	FUNCTION
IEEE 488 PORT J5	1	DI01	I/O Line
	2	DI02	I/O Line
	3	DI03	I/O Line
	4	DI04	I/O Line
	5	EOI	End or Identify
	6	DAV	Data Valid
	7	NRFD	Not Ready for Data
	8	NDAC	Not Data Accepted
	9	IFC	Interface Clear
	10	SRQ	Service Request
	11	ATN	Attention
	12	SHIELD	Shield
	13	DI05	I/O Line
	14	DI06	I/O Line
	15	DI07	I/O Line
	16	DI08	I/O Line
	17	REN	Remote Enable
	18	GND	Ground (signal common)
	19	GND	Ground (signal common)
	20	GND	Ground (signal common)
	21	GND	Ground (signal common)
	22	GND	Ground (signal common)
	23	GND	Ground (signal common)
	24	LOGIC GND	Logic Ground

### 2.3 PRELIMINARY OPERATIONAL CHECK

A simple operational check after unpacking and before equipment installation is advisable to ascertain whether the power supply has suffered damage resulting from shipping.

Refer to Figures 2-1, 2-2 and 3-1 for location of operating controls and electrical connections. Table 3-1 explain the functions of operating controls/indicators. Refer to PAR. 3.3 for a description of basic operating techniques.

#### 2.3.1 PRELIMINARY OPERATIONAL CHECK USING ANALOG CONTROL

1. With POWER switch set to off position, verify that the power-up switches at the top cover are set to the factory default positions shown in Figure 2-3. This establishes GPIB address 6, standalone operation, Voltage mode, Analog Input enabled and internal  $\pm$ current limits enabled and set to maximum.

NOTE: The unit is shipped with load type set to Active (for inductive loads). If necessary, refer to 3.3.6 for an explanation of load types and to PAR. 3.3.2.1 to change the load type. The logic for Remote on/off input at pin 2 of the Trigger port is set to high (1) or open circuit for output on, low (0) or short circuit for output off.

S1: 00110 = GPIB ADDRESS 6  
 S2: 00001 = STANDALONE  
 S3: 11111 = VOLTAGE MODE,  
 ANALOG INPUT ON  
 ±V AND ±C PROTECT MAX SET  
 TO MAXIMUM

3043448

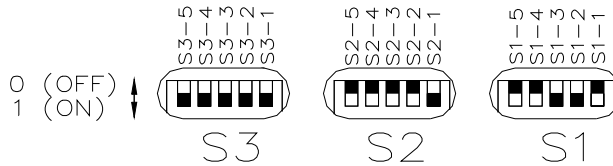

**FIGURE 2-3. FACTORY DEFAULT POWER-UP SWITCH SETTINGS**

2. Connect a twisted wire pair (either #24 or #22 AWG) to the mating connector for the Analog I/O port pins 11 and 10. Connect +10V d-c  $\pm 0.1\text{mV}$  to pin 11, referenced to pin 10, then install the mating connector on the Analog I/O port at the rear panel.

**CAUTION: DO NOT repeatedly toggle the POWER circuit breaker/switch as this may damage the unit.**

3. Connect the power supply to source power (see PAR. 2.5.2). With no load connected, set POWER switch to the ON position.
4. Each time the unit is turned on an internal self-test is performed. If the unit passes, it initializes with the power-up settings established in step 1 and the front panel POWER/FAULT/LIMIT light is green (power good), the DIGITAL CONTROL light is not lit (analog input enabled) and the VOLTAGE/CURRENT light is green (voltage mode), MASTER/SLAVE light is green (standalone or master configuration) and the OUTPUT ON light is lit (output enabled). If the front panel POWER/FAULT/LIMIT light is red, the unit has failed self-test; contact Kepco for further instructions. If the unit beeps, or the MASTER/SLAVE or VOLTAGE/CURRENT light blinks, refer to PAR. 3.8 for troubleshooting.
5. Connect a digital voltmeter (DVM) (resolution and accuracy of 0.01% or better) to the OUT S and COM S terminals at the rear panel terminal block.
6. Verify DVM voltage reading matches the nominal voltage of the unit within 0.01% of rated maximum voltage.

### 2.3.2 PRELIMINARY OPERATIONAL CHECK USING DIGITAL CONTROL

1. With POWER switch set to off position, verify that the power-up switches at the top cover are set to the factory default positions shown in Figure 2-3. This establishes GPIB address 6, standalone operation, Voltage mode, Analog Input enabled and internal  $\pm$ current limits enabled and set to maximum.
2. Set Power-up switch S3-2 to 0 (off) to disable Analog Input.

NOTE: The unit is shipped with load type set to Active (for inductive loads). If necessary, refer to 3.3.6 for an explanation of load types and to PAR. 3.3.2.1 to change the load type.

3. Connect a twisted wire pair (either #24 or #22 AWG) to the mating connector for the Analog I/O port pins 11 and 4. Connect +10V d-c  $\pm 0.1\text{mV}$  to pin 11, referenced to pin 4., then install the mating connector on the Analog I/O port at the rear panel.
4. Connect the GPIB or RS 232 cable coming from the host computer to the appropriate port (GPIB or RS 232) at the BOP rear panel.

**CAUTION: DO NOT repeatedly toggle the POWER circuit breaker/switch as this may damage the unit.**

5. Connect the power supply to source power (see PAR. 2.5.2). With no load connected, set POWER switch to the ON position.
6. Each time the unit is turned on an internal self-test is performed. If the unit passes, it initializes with the power-up settings established in step 1 and the front panel POWER/FAULT/LIMIT light is green (power good), the DIGITAL CONTROL light is not lit (analog input enabled) and the VOLTAGE/CURRENT light is green (voltage mode), MASTER/SLAVE light is green (standalone or master configuration) and the OUTPUT ON light is lit (output enabled). If the front panel POWER/FAULT/LIMIT light is red, the unit has failed self-test; contact Kepeco for further instructions. If the unit beeps, or the MASTER/SLAVE or VOLTAGE/CURRENT light blinks, refer to PAR. 3.8 for troubleshooting.
7. Send the following SCPI commands:

*IDN?	The unit responds with model number and serial number.
FUNC:MODE VOLT	Puts the unit in Voltage Mode.
VOLT:MODE FIX	Allows digital control of the output.
CURR:PROT:LIM xx	xx is the nominal current rating of the unit.
VOLT yy	yy is the nominal voltage rating of the unit.
OUTP ON	Enables the output.
MEAS:VOLT?	Measures output voltage and returns value to host computer.
8. Connect a digital voltmeter (DVM) (resolution and accuracy of 0.01% or better) to the OUTPS and COMS terminals at the rear panel terminal block.
9. Verify DVM voltage reading matches the nominal voltage of the unit within 0.01% of rated maximum voltage.

## 2.4 INSTALLATION

### 2.4.1 RACK MOUNTING

The unit is shipped with four feet attached to bottom of the unit which must be removed prior to installation (see Figure 1-2). The BOP is designed to be rack mounted in a standard 19-inch wide rack using the mounting ears (supplied) attached to the front panel (see Figure 1-2). Allow a minimum of 1.0 in. (25.4 mm) in front of the unit to permit air intake necessary for proper cooling of the unit. **CAUTION: The rack must provide support at the rear (within 6 inches of the rear panel). Optional slides can also be used (see PAR. 2.4.2).**

### 2.4.2 SLIDE INSTALLATION

Optional slides are available for rack mounting (see Table 1-5 and Figure 1-2).

## 2.5 WIRING INSTRUCTIONS

Interconnections between an a-c power source and a power supply, and between the power supply and its load are as critical as the interface between other types of electronic equipment. If optimum performance is expected, certain rules for the interconnection of source, power supply and load must be observed by the user. These rules are described in detail in the following paragraphs.

**CAUTION: When working with active loads, the voltage or current of the active load must not exceed the maximum voltage or current rating of the BOP. Otherwise the overvoltage or overcurrent protection will shut down the power supply.**

### 2.5.1 SAFETY GROUNDING

Local, national and international safety rules dictate the grounding of the metal cover and case of any instrument connected to the a-c power source, when such grounding is an intrinsic part of the safety aspect of the instrument. The ground terminal of the source power connector (Figure 2-1) is connected to the chassis and the instructions below suggest wiring methods which comply with these safety requirements; however, in the event that the specific installation for the power system is different from the recommended wiring, it is the customer's responsibility to ensure that all applicable electric codes for safety grounding requirements are met. As a precaution, always connect the stud marked  at the rear panel to proper earth ground.

### 2.5.2 SOURCE POWER CONNECTIONS

Source power is connected to the power supply via three-wire input power using the source power mating connector supplied (see Table 1-3). See Table 1-2 for source power specifications. This power supply operates from single phase a-c mains power (or between two phases of 3-phase a-c mains power) over the specified voltage and frequency ranges (Table 1-2) without any need for range selection. The user must provide a properly sized and rated mains lead (line cord) and service with a current rating compatible with the anticipated input current. Line cords available as accessories are listed in Table 1-4. Kepco recommends #12 AWG (2,0 mm diameter) for input line cord.

### 2.5.3 D-C OUTPUT GROUNDING

Connections between the power supply and the load and sensing connections may, despite all precautions such as shielding, twisting of wire pairs, etc., be influenced by radiated noise, or "noise pick-up". To minimize the effects of this radiated noise the user should consider grounding one side of the power supply/load circuit. The success of d-c grounding requires careful analysis of each specific application, however, this recommendation can only serve as a general guideline.

One of the most important considerations in establishing a successful grounding scheme is to avoid GROUND LOOPS. Ground loops are created when two or more points are grounded at different physical locations along the output circuit. Due to the interconnection impedance between the separated grounding points, a difference voltage and resultant current flow is superimposed on the load. The effect of this ground loop can be anything from an undesirable increase in output noise to disruption of power supply and/or load operation. The only way to avoid ground loops is to ensure that the entire output/load circuit is fully isolated from ground, and only then establish a single point along the output/load circuit as the single-wire ground point.



The exact location of the "best" d-c ground point is entirely dependent upon the specific application, and its selection requires a combination of analysis, good judgement and some amount of empirical testing. If there is a choice in selecting either the OUTPUT or COMMON output terminals of the power supply for the d-c ground point, both sides should be tried, and preference given to the ground point producing the least noise. For single, isolated loads the d-c ground point is often best located directly at one of the output terminals of the power supply; when remote error sensing is employed, d-c ground may be established at the point of sense lead attachment. In the specific case of an internally-grounded load, the d-c ground point is automatically established at the load.

The output and common terminals of BOP power supplies are d-c isolated ("floating") from the chassis in order to permit the user maximum flexibility in selecting the best single point ground location. Care must be taken in measuring the ripple and noise at the power supply: measuring devices which are a-c line operated can often introduce additional ripple and noise into the circuit.

There is, unfortunately, no "best" method for interconnecting the load and power supply. Individual applications, location and nature of the load require careful analysis in each case. Grounding a single point in the output circuit can be of great importance. It is hoped that the preceding paragraphs will be of some assistance in most cases. For help in special applications or difficult problems, consult directly with Kepco's Application Engineering Department.

#### **2.5.3.1 GROUNDING NETWORK CONFIGURATION**

When the output is floating there is a tendency for large changes in output voltage to affect the digital programming section, possibly resulting in an erroneous output. Decoupling capacitors from each of the two output terminals to the chassis via a terminal block link form a grounding network. The grounding network is designed to reduce high frequency noise and ensure that the digital programming section is not adversely affected by the dynamic swing of the output. The power supply is shipped with the grounding network connected: a connection between terminals TB1-4 (GND NET) and TB1-5 (GND). To disconnect the grounding network from the output, remove the connection across TB1-4 and TB1-5.

#### **2.5.4 POWER SUPPLY/LOAD INTERFACE**

The general function of a voltage- or current-stabilized power supply is to deliver the rated output quantities to the connected load. The load may have any conceivable characteristic: it may be fixed or variable, it may have predominantly resistive, capacitive or inductive parameters; it may be located very close to the power supply output terminals or it may be a considerable distance away. The perfect interface between a power supply and its load would mean that the specified performance at the output terminals would be transferred without impairment to any load, regardless of electrical characteristics or proximity to each other.

The stabilized d-c power supply is definitely not an ideal voltage or current source, and practical interfaces definitely fall short of the ideal. All voltage-stabilized power supplies have a finite source impedance which increases with frequency, and all current-stabilized power supplies have a finite shunt impedance which decreases with frequency. The method of interface between the power supply output and the load must, therefore, take into account not only the size with regard to minimum voltage drop, but the configuration with regard to minimizing the impedance introduced by practical interconnection techniques (wire, bus bars, etc.). The series inductance of the load wire must be as small as possible as compared to the source inductance of the power supply: although the error sensing connection to the load compensates for the d-c voltage drop in the power leads, it cannot compensate for the undesirable output effects of the power lead inductance. These lead impedances (both power and sensing leads) are especially

important if the load: is constantly modulated or step-programmed; has primarily reactive characteristics; or where the dynamic output response of the power supply is critical to load performance.

### 2.5.5 LOAD CONNECTION - GENERAL

Load connections require wires that are properly rated for the nominal output current of the unit. Load connections to the BOP power supply are achieved via the OUTPUT and COMMON bus bar-type terminals located on the rear panel. A barrier strip is provided at the rear panel for connection of the sense wires to the load (for remote sensing or multiple unit applications).

**CAUTION:** Never connect the load to the sense terminals. Monitoring instruments (e.g., DVM, etc.) are the only external equipment that may be safely connected to the sense terminals.

**CAUTION:** Never connect the BOP OUTPUT terminal (or the load terminal tied to the OUTPUT terminal) to earth-ground. Otherwise, if the controlling device is grounded, the BOP can be damaged by the protection limit output current flowing inside the BOP along the programming signal return path.

**CAUTION:** Do not connect both the load and the programming device return (common) to earth-ground potential. Otherwise, if the COMMON power connection between the BOP and the load is lost, then the BOP can be damaged by output current flowing inside the BOP along the programming signal return path.

**CAUTION:** The safety features incorporated into the BOP to handle energy from Active loads are unable to protect the power supply or the load if input power to the BOP is lost or if the BOP Malfunctions. It is recommended that the user monitor "Power OK" flag pins 3 and 4 of the external Protect Port (see Table 2-5) and implement a fast-acting means of disconnecting capacitive loads or crowbaring inductive loads to prevent damage to both the BOP and the load in the event of input power loss.

**NOTE:** Regardless of output configuration, either local or remote output sense lines must be connected for operation.

1. **Observe Polarities:** The **OUT S** sensing wire must be connected to the **OUTPUT** load wire, and the **COM S** sensing wire must be connected to the **COMMON** load wire.

2. If local sensing is used, install links (see Figure 2-4).

### 2.5.6 LOAD CONNECTION USING LOCAL SENSING

Figure 2-4 shows a typical configuration using local sensing and a grounded load; for local sensing with an isolated ("floating") load, do not install the ground connection (see Figure 2-4, Note 2).

## **2.5.7 LOAD CONNECTION USING REMOTE SENSING**

Figure 2-5 shows a typical configuration using remote sensing and a grounded load; for remote sensing with an isolated (“floating”) load, do not install the ground connection (see Figure 2-5, Note 2). Use #22 AWG wire, twisted pair for remote sense connections.

## **2.6 COOLING**

The power devices used within the power supply are maintained within their operating temperature range by means of internal heat sink assemblies and by two cooling fans. Periodic cleaning of the power supply interior is recommended. Do not obstruct any vents on the unit. If the power supply is located within a confined space, take care that the ambient temperature, which is the temperature of the air immediately surrounding the power supply, does not rise above the specified limits (see Table 1-2).

## **2.7 SETTING UP THE UNIT**

The following paragraphs describe the connections and initial BOP setup needed to operate in the desired mode.

### **2.7.1 POWER-UP SETTINGS**

The BOP uses three DIP switches (S1, S2, S3 shown in Figure 2-2 and explained in Table 2-2), each with five segments to establish initial conditions upon power-up. These switches can be configured for a) Reset Power-up or b) Normal Power-up.

Reset Power-up (PAR. 3.3.2.1) is used to change the load type (load type determines how the unit responds to the output OFF command, see PAR. 3.3.6), logic of The Remote On/Off signal at pin 2 of the Trigger port, and baud rate. Reset power-up also resets the limits to factory defaults (see PAR. B.145). When using the unit on for the first time, refer to PAR. 3.3.2.1 to perform a Reset power-up.

Normal Power-up (PAR. 3.3.2.2) is used to establish the GPIB address, configure the unit as either standalone or part of a multi-unit configuration, and establish how the unit is to be controlled (analog or digital), select operating mode (voltage or current), and select how protection limits are to be controlled.

Refer to PAR. 3.2 for a summary of factory default settings established by the power-up switches. The Reset Power-up (PAR. 3.3.2.1) must be used to change the load type, baud rate or reverse the logic of Remote On/Off logic at Trigger port pin 2. Otherwise refer to PAR. 3.3.2.2 to establish normal power-up settings.

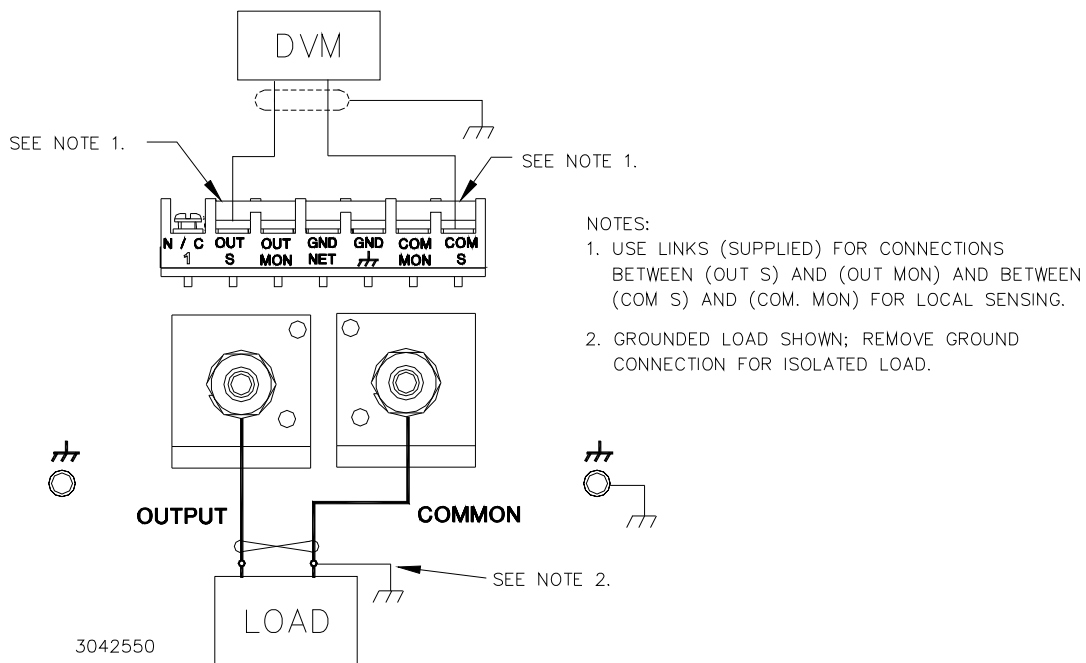

**FIGURE 2-4. LOAD CONNECTIONS, LOCAL SENSING**

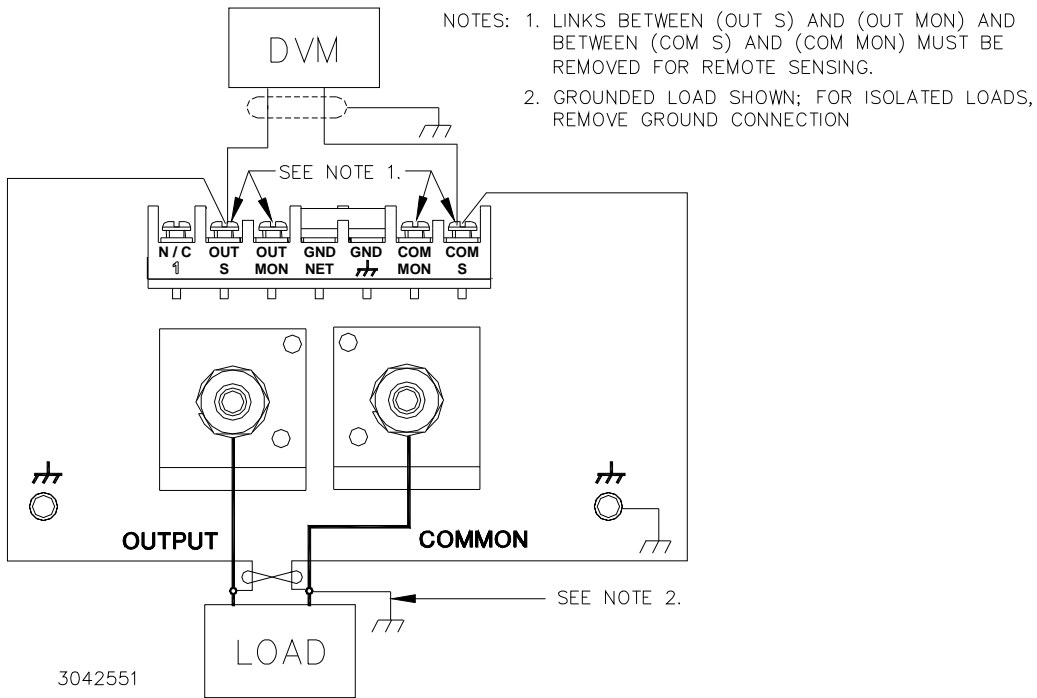

**FIGURE 2-5. LOAD CONNECTIONS, REMOTE SENSING**

## 2.7.2 SETUP FOR ANALOG CONTROL

1. With power off configure the power-up setup switches (see Table 2-2 for details). Setup for analog control can be accomplished through the power-up switches in one of two ways:
  - a. Setting S3-5 (MSB) through S3-1 (LSB) to 0 (off) [00000] is a unique configuration that allows external signals applied to the I/O port to control the BOP upon power-up: Analog Input ON (main channel reference, pin 11 of Analog I/O port) enabled, limit channel references (pins 5, 6, 13 and 14 of Analog I/O port) enabled, Voltage/Current mode is established by pin 2 of Analog I/O port (1 or open = voltage mode, 0 or short = current mode) and output is set to ON (enabled).
  - b. Setting S3-5 to 1 allows S3-1 through S3-4 to determine how the unit is controlled.
    - Set S3-1 to either 1 for Voltage mode or 0 for Current mode
    - Set S3-2 to 1 to enable analog control (allow the main channel to be controlled by the external reference applied to analog I/O Port pin 11).
    - Set S3-3 and S3-4 to configure the protection limits (see Table 2-2).
2. Connect the load and programming and monitoring equipment as shown in Figure 2-6.

## 2.7.3 SETUP FOR DIGITAL CONTROL VIA GPIB

1. With all power off, connect the load to the BOP using either local or remote sensing. If units are to be connected in series or parallel, refer to PAR. 2.8. Connect the GPIB connector to the GPIB port (see Figure 2-1 and Table 2-1).

**CAUTION:** To ensure correct operation, do not remove the GPIB cable from the BOP after a Query is processed. Ensure that the last command is a non-query such as \*CLS before removing the GPIB cable. Otherwise, power to the BOP and/or the host computer may need to be cycled OFF then ON to restore proper operation.

2. Refer to Table 2-2 and configure GPIB address, power-up settings, and master/slave status. Set S3-5 to 1 and S3-2 to 0 to set Analog Input to OFF.
3. Refer to PAR. 3.3.2.2 to turn power on.
4. Refer to PAR. 3.3 for power supply basics and PAR. 3.6 for remote mode programming. SCPI programming is described in PAR. 3.7; Appendices A and B provide syntax for SCPI common and subsystem commands and queries implemented in this unit.

## 2.7.4 SETUP FOR DIGITAL CONTROL VIA RS 232C

1. With all power off, connect the load to the BOP using either local or remote sensing (refer to PAR. 2.5).
2. If units are to be connected in series or parallel, refer to PAR. 2.8.
3. Connect the RS 232 connector to the RS 232 port (see Figure 2-1 and Table 2-1).
4. The default baud rate is 9600. The baud rate can be set to 19.2K by performing reset power-up (PAR. 3.3.2.1) with switch S3-1 set to 1.
5. Refer to PAR. 3.3.2.2 to turn power on.

Refer to PAR. 3.3 power supply basics and PAR. 3.7 for RS 232 operation. SCPI programming is described in PAR. 3.7; Appendices A and B provide syntax for SCPI common and subsystem commands and queries implemented in this unit. Refer to PAR. 3.6.4.3 to configure the RS 232 Port.

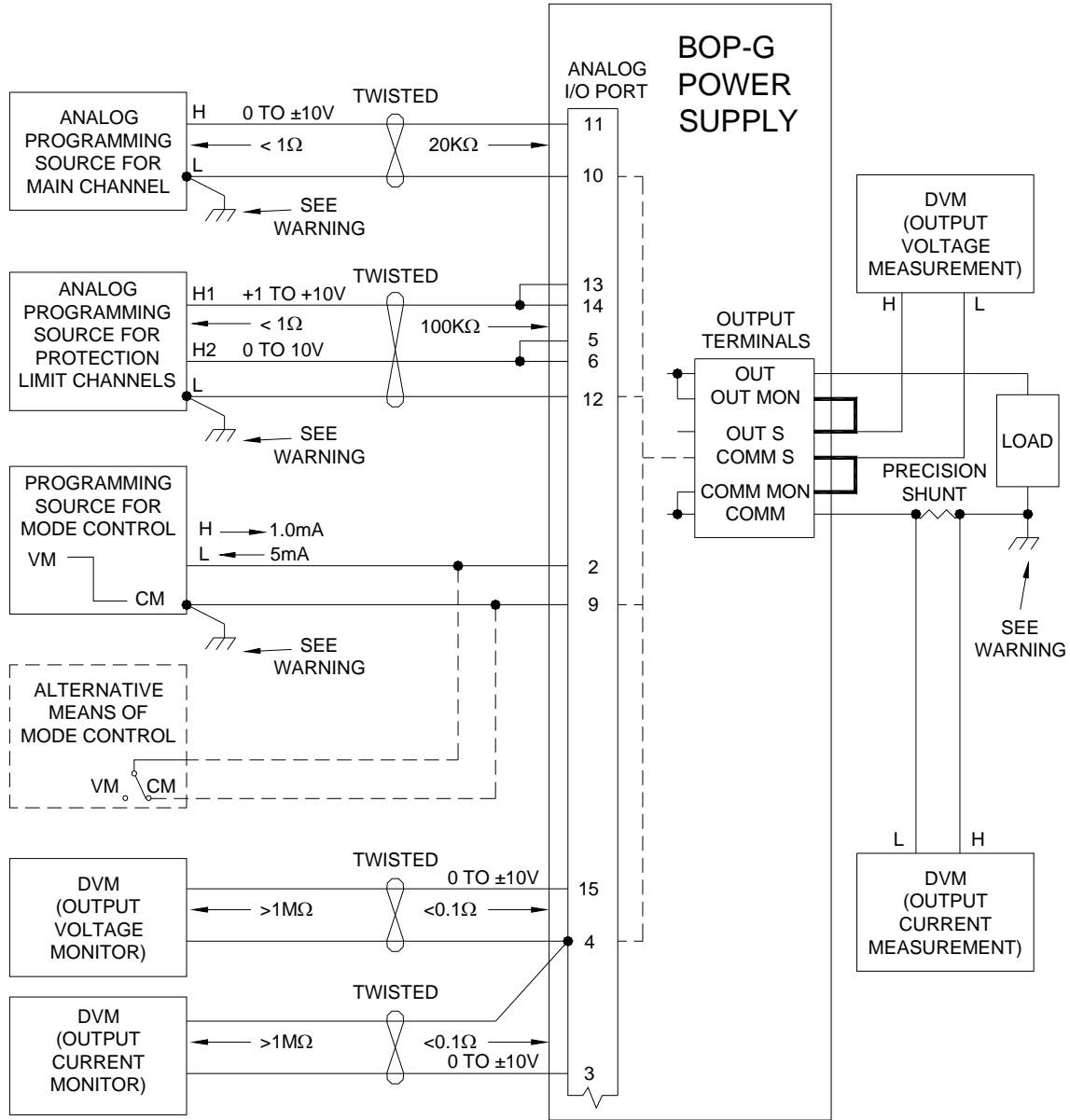

WARNING: IF THE LOAD IS GROUNDING, THE PROGRAMMING DEVICES AND THE MONITORING INSTRUMENTS MUST BE FLOATING. IF THE LOAD IS FLOATING, THE PROGRAMMING DEVICES AND MONITORING INSTRUMENTS CAN BE GROUNDING.

NOTE: USE AWG #24 OR AWG #22 WIRE FOR PROGRAMMING AND MONITORING/MEASURING DEVICE INTERCONNECTIONS.

3044248

FIGURE 2-6. CONNECTIONS FOR ANALOG CONTROL AND MONITORING OF BOP-G POWER SUPPLY.

## 2.8 MULTIPLE UNIT CONFIGURATIONS

Parallel and series configurations of identical BOP units increase the rated voltage and current range of the power supply. Up to two units (three units for model BOP 10-100G) can be connected in parallel to increase the current:  $I_{MAX (one\ unit)} \times N_P = I_{MAX (parallel\ combination)}$  where  $N_P$  = number of units in parallel. Similarly, up to two units can be connected in series to increase the voltage:  $E_{MAX (one\ unit)} \times N_S = E_{MAX (parallel\ combination)}$  where  $N_S$  = number of units in series. For configurations requiring more than two units in series or parallel, contact Kepco. Multiple unit configurations require the appropriate Interconnection Kit (see Table 1-5).

For all multiple unit configurations the master reports the system output parameters: voltage and current; the slaves display and send to the master their own main channel parameter: voltage for series configurations or current for parallel configurations.

Additional hex nuts are provided in the interconnection kit for sufficient cable separation so they can be oriented as needed to fit onto the terminal.

NOTE: Multiple unit configurations require that all individual units be properly calibrated. (Units shipped from Kepco have been factory-calibrated.) If not, refer to Section 4 to calibrate the individual units prior to connecting them in parallel or series. Using calibrated units ensures that the multiple unit configuration is calibrated; calibrating the multiple unit configuration is neither needed nor possible.

### 2.8.1 MULTIPLE UNIT CONNECTIONS

Before connecting the units in parallel or in series, turn off all units and remove any previous interconnections between units as well as connections to the load

Refer to Table 2-2 and configure the top cover power up switches S1 through S3 of each unit for the desired configuration master/slave, series/parallel (S2), GPIB address if desired (S1), and additional settings (S3) as needed. Then turn on each unit for approximately 10 seconds to allow the settings of S1, S2 and S3 to be stored.

Turn off the units, then proceed with the parallel or series connection. Figures 2-7 (local sensing) and 2-8 (remote sensing) show the connections for three parallel-connected units; Figures 2-9 (local sensing) and 2-10 (remote sensing) show the connections for three series-connected units. These figures allow other configurations, e.g., two parallel- or series-connected units to be easily deduced. Consult factory for configurations requiring more than two units in series or parallel (three units in parallel for BOP 10-100G).

**CAUTION: For both parallel and series configurations, remove links between (COM S) and (COM OUT) terminals of all slaves to prevent damage to the unit and maintain system accuracy. Make sure to accurately follow Figures 2-7 through 2-10 for proper connection of the units.**

The following connections are required.

- Power cables
- Sense connections (either local or remote)
- Interconnection cables and terminations required for parallel or series configurations are supplied in the applicable Interconnection Kit (see Table 1-5 for part number).

CAUTION: REMOVE LINK BETWEEN (COM S) AND (COM MON) AT ALL SLAVES TO PREVENT DAMAGE TO THE BOP AND MAINTAIN SYSTEM ACCURACY.

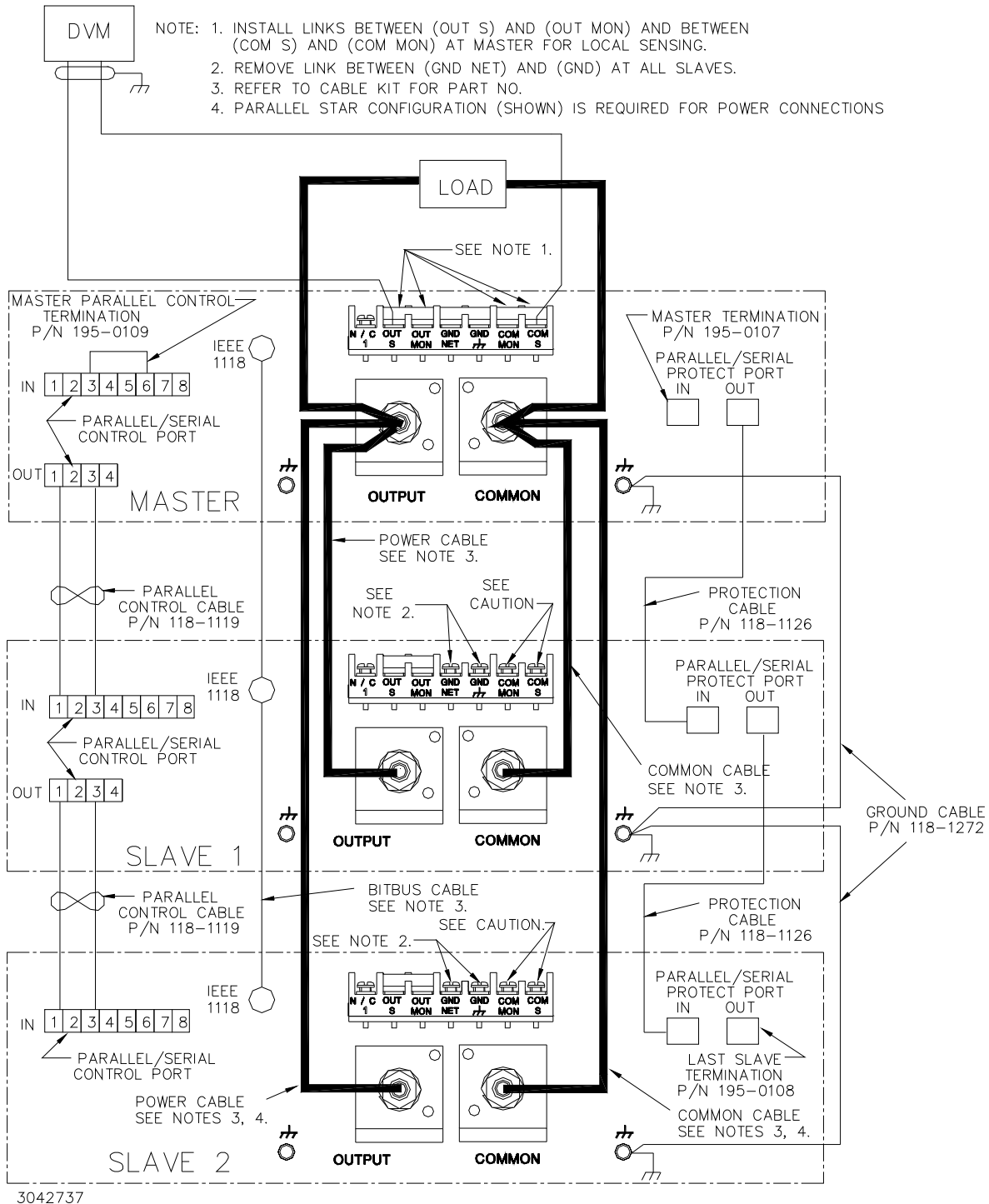

NOTE: Consult factory for configurations requiring more than two units in parallel.

FIGURE 2-7. PARALLEL CONFIGURATION, LOCAL SENSING, TYPICAL



CAUTION: REMOVE LINK BETWEEN (COM S) AND (COM MON) AT ALL SLAVES TO PREVENT DAMAGE TO THE BOP AND MAINTAIN SYSTEM ACCURACY.

- NOTE: 1. REMOVE LINKS BETWEEN (OUT S) AND (OUT MON) AND BETWEEN (COM S) AND (COM MON) AT MASTER FOR REMOTE SENSING.  
 2. REMOVE LINK BETWEEN (GND NET) AND (GND) AT ALL SLAVES.  
 3. REFER TO CABLE KIT FOR PART NO.  
 4. PARALLEL STAR CONFIGURATION (SHOWN) IS REQUIRED FOR POWER CONNECTIONS.  
 5. USE #22 AWG WIRE FOR ALL SENSE CONNECTIONS.

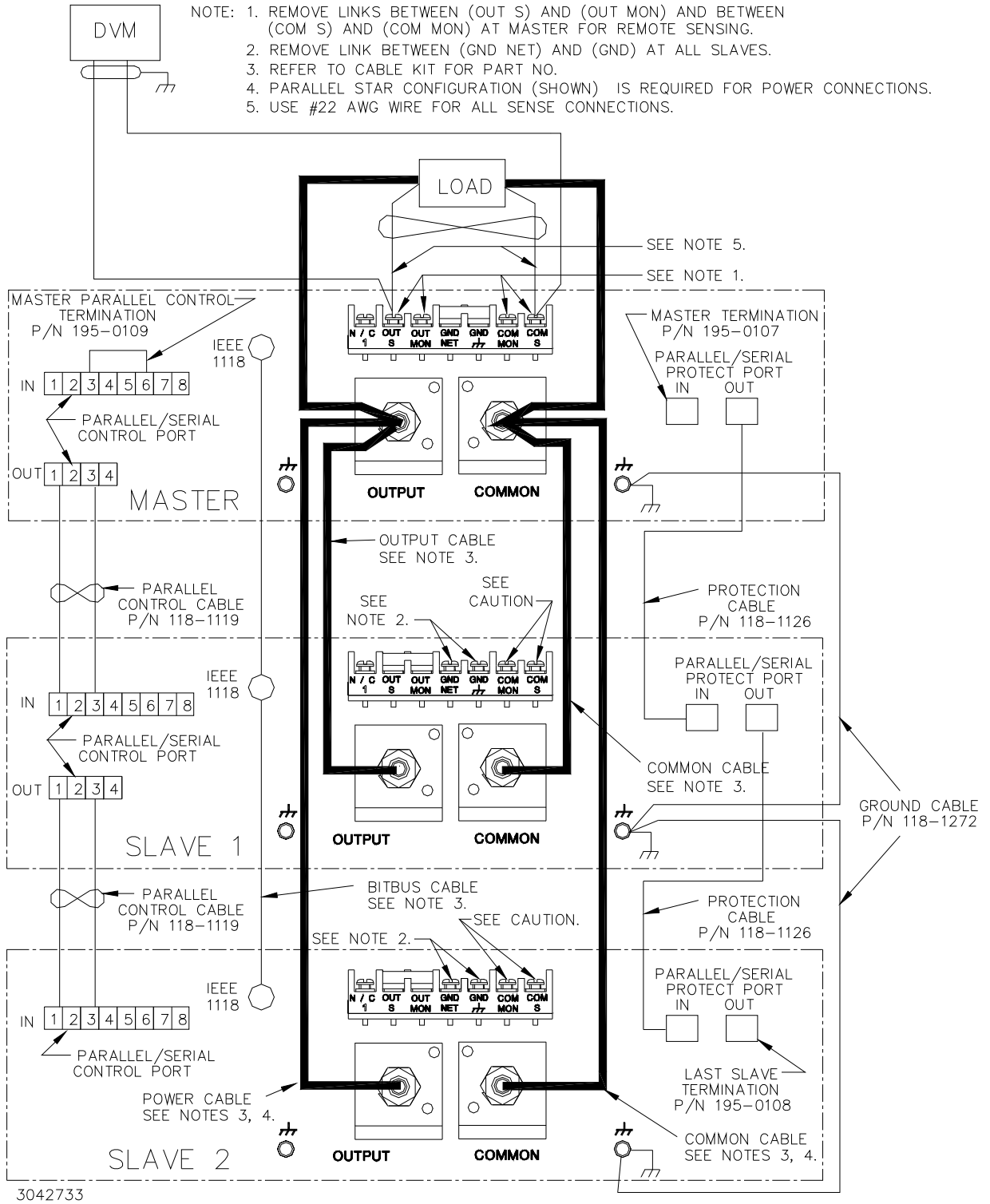

NOTE: Consult factory for configurations requiring more than two units in parallel.

FIGURE 2-8. PARALLEL CONFIGURATION, REMOTE SENSING, TYPICAL

- NOTES: 1. REMOVE LINK BETWEEN (GND NET) AND (GND) FOR SLAVE.  
 2. REMOVE LINK BETWEEN (COM S) AND (COM MON) AT SLAVE TO COMPENSATE FOR DROP IN POWER CONNECTIONS.  
 3. REFER TO CABLE KIT FOR PART NO.  
 4. INSTALL LINKS BETWEEN (COM S) AND (COM OUT) AT MASTER AND BETWEEN (OUT S) AND (OUT MON) AT SLAVE FOR LOCAL SENSING.  
 5. IF (N/C) TERMINAL IS LABELED (COMP), INSTALL LINK BETWEEN (COMP) AND (OUT S) TO ENSURE STABLE OPERATION IN SERIES.

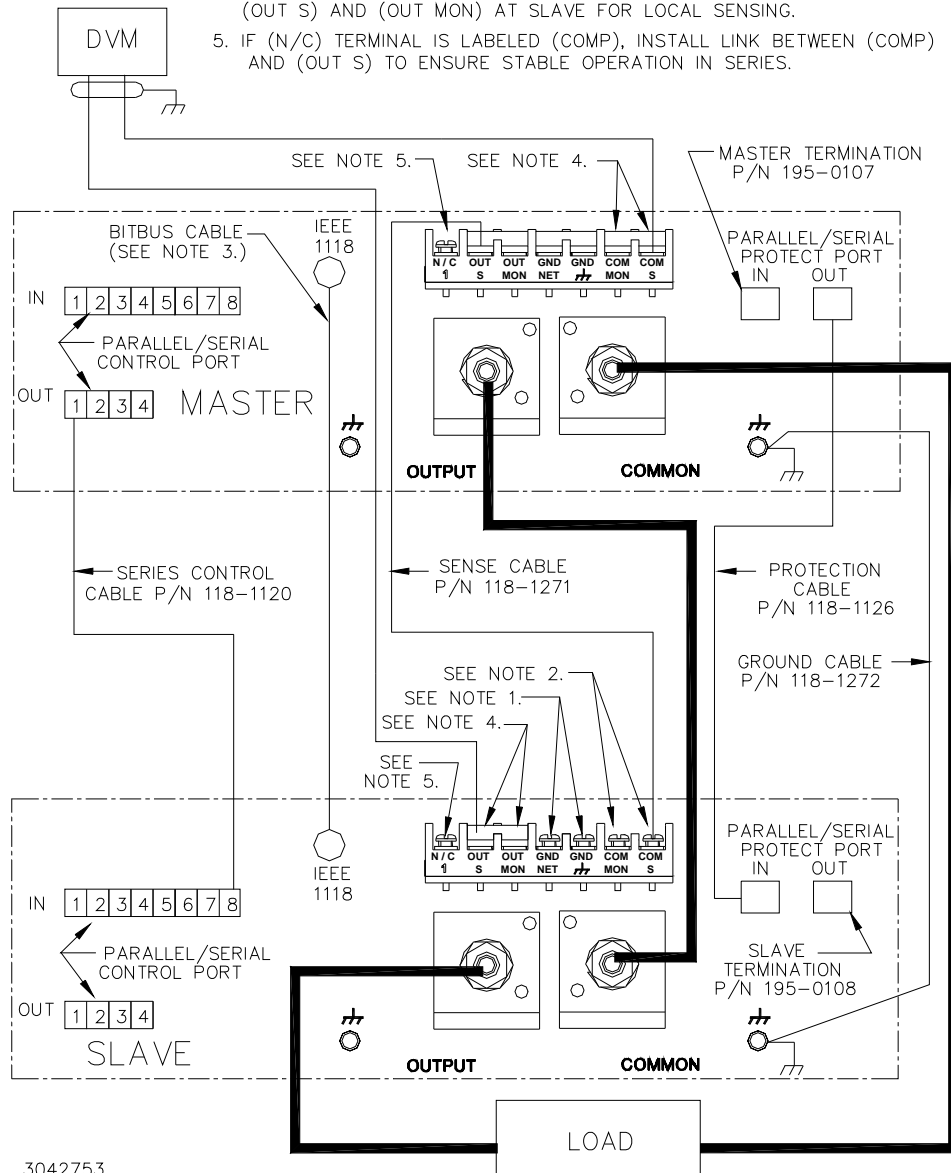

NOTE: Consult factory for configurations requiring more than two units in series.

FIGURE 2-9. SERIES CONFIGURATION, LOCAL SENSING, TYPICAL

- NOTES: 1. REMOVE LINK BETWEEN (GND NET) AND (GND) FOR SLAVE.  
 2. REMOVE LINK BETWEEN (COM S) AND (COM MON) AT SLAVE TO COMPENSATE FOR DROP IN POWER CONNECTIONS.  
 3. REFER TO CABLE KIT FOR PART NO.  
 4. REMOVE LINK BETWEEN (COM S) AND (COM MON) AT MASTER AND BETWEEN (OUT S) AND (OUT MON) AT SLAVE FOR REMOTE SENSING.  
 5. USE #22 AWG WIRE FOR SENSE CONNECTIONS FROM BOP 1KW TO LOAD.  
 6. IF (N/C) TERMINAL IS LABELED (COMP), INSTALL LINK BETWEEN (COMP) AND (OUT S) TO ENSURE STABLE OPERATION IN SERIES.

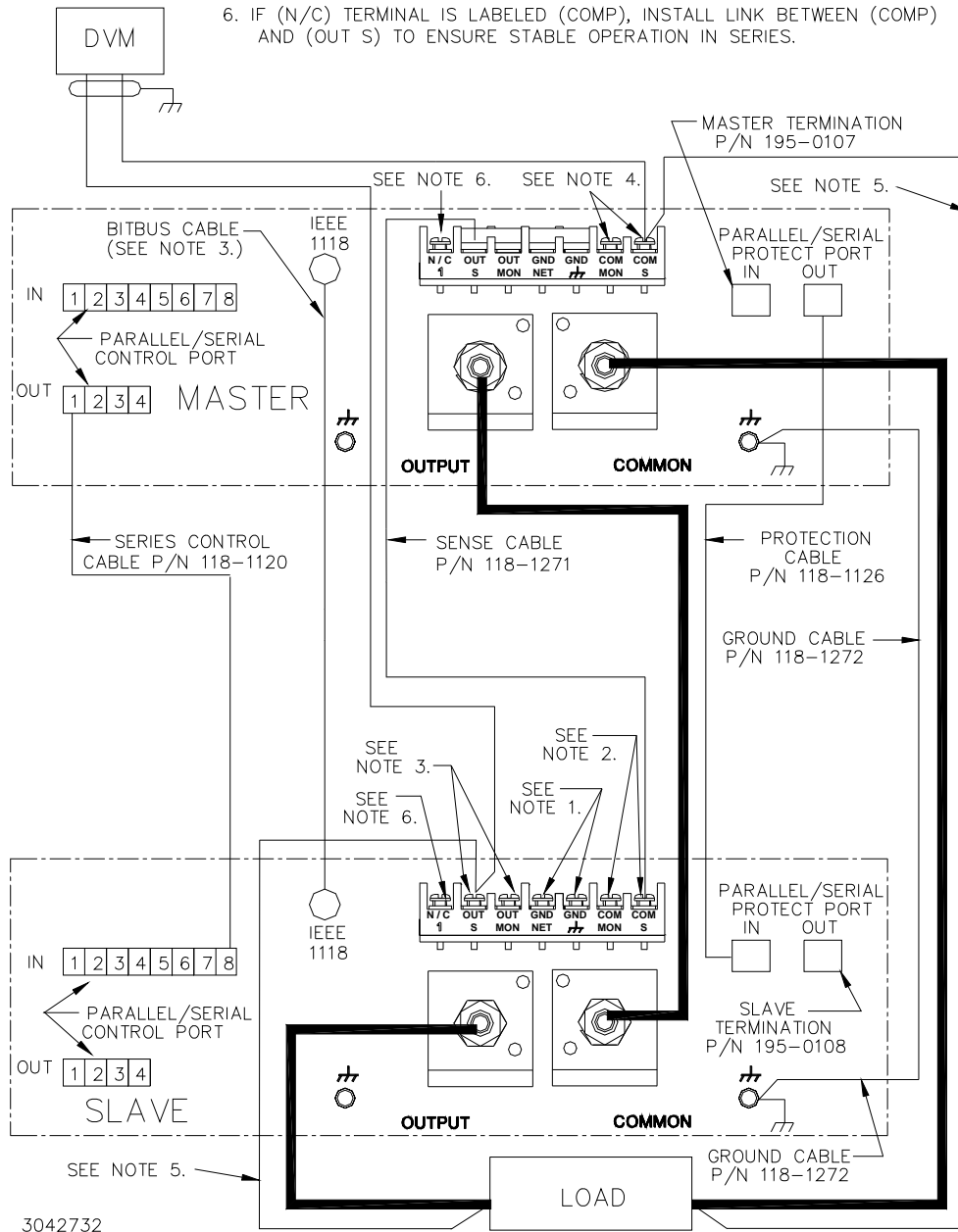

NOTE: Consult factory for configurations requiring more than two units in series.

FIGURE 2-10. SERIES CONFIGURATION, REMOTE SENSING, TYPICAL

## 2.8.2 MULTIPLE UNIT SOURCE POWER

When multiple units are connected in series or parallel, the individual power supplies of the system may be connected to different phases of a 3-phase a-c power source.

## 2.8.3 MULTIPLE UNIT PROTECTION

For multiple unit configurations it is necessary to configure the protection so that a fault will shut down all the interconnected power supplies. Figure 2-11 is a simplified diagram showing typical protection interconnections for master/slave configurations. These interconnections are done using the special cables and terminations supplied in the applicable Interconnection Kit available as an accessory (see Table 1-5).

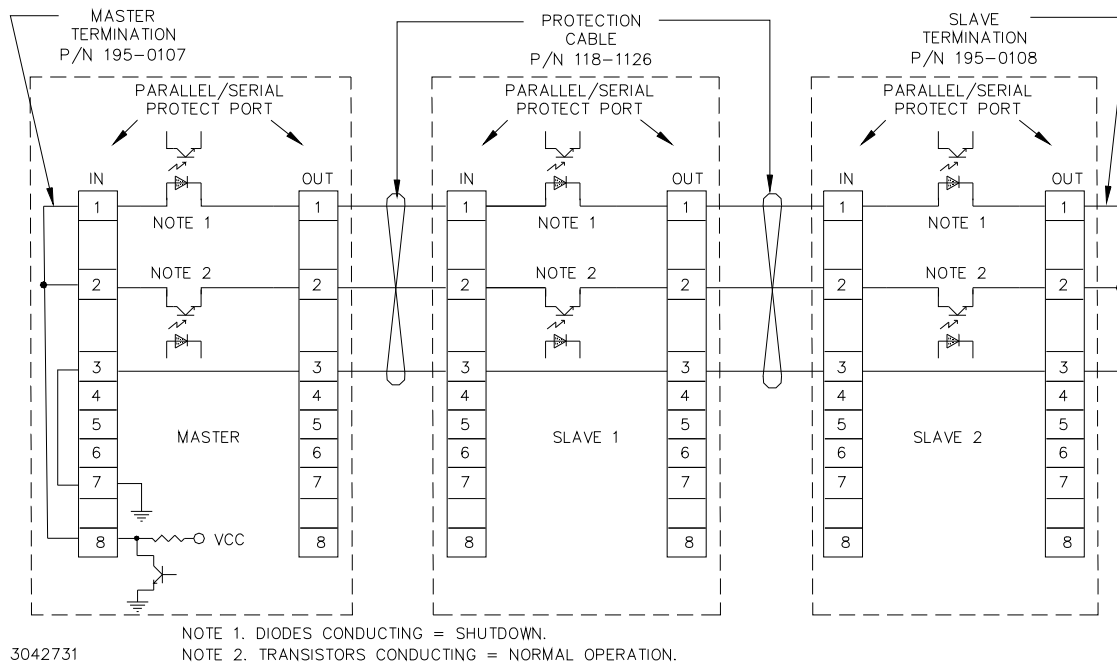

**FIGURE 2-11. TYPICAL MASTER/SLAVE PROTECTION INTERCONNECTIONS**

Upon startup, PAR/SER PROT IN PORT pin 8 of the master goes low, and stays low until all slaves are powered up. Normal power up of a unit causes the transistor connecting PAR/SER PROT IN PORT pin 2 and PAR/SER PROT OUT PORT pin 2 to conduct. The transistors of all units are connected in series, effectively shorting out all the shutdown diodes (the shutdown diodes of all units are also connected in series) connecting PAR/SER PROT IN PORT pin 1 and PAR/SER PROT OUT PORT pin 1. After all the units are powered up and operating normally, the low at PAR/SER PROT IN PORT pin 8 changes to high, but the conducting transistors keep the voltage at pin 8 low and the diodes are cut off. If a fault occurs, the transistor between PAR/SER PROT IN PORT pin 2 and PAR/SER PROT OUT PORT pin 2 of the defective unit is cut off, allowing current to flow through the shutdown diodes. This develops internal shutdown signals that shut down all units.

## 2.8.4 OPERATING INSTRUCTIONS FOR MULTIPLE UNIT COMBINATIONS

1. Before either installing the units in a rack or stacking and connecting them one on top of the other, configure the power-up settings as desired while the units are turned off.
  - a. For master unit, perform the Reset Power-up (see PAR. 3.3.2.1) to establish the load type, logic for trigger port pin 2 (output on/off) and RS 232 baud rate (this also resets limits to factory default settings (see PAR. B.145).
  - b. Configure the master/slave power-up switches (S2-1 through S2-5) for each unit per Table 2-2.
  - c. Configure the mode control power-up switches (S3-1 through S3-5). For analog control refer to PAR. 2.7.2, for digital control via GPIB refer to PAR. 2.7.3 and for digital control via RS 232 refer to PAR. 2.7.4.

NOTES:

- It is not necessary to set power-up switch S3 segments for the slaves. Power-up configuration is established automatically: mode of operation is established by the series or parallel configuration switch S2-2 of each unit, the analog inputs are disabled, and the limit channels are set for maximum internal values
- After setting the power-up switches S1 through S3, turn on each unit for approximately 10 seconds to allow the unit to store the settings. Then turn off the units and proceed to step 2.

2. Install the units in the rack, or stack them one on top of the other, then use the cables and terminations supplied in the applicable Interconnection Kit (available as an accessory, see Table 1-5) per Figures 2-7 through 2-10 as applicable. Figures 2-7 (local sensing) and 2-8 (remote sensing) show the connections for three parallel-connected units; Figures 2-9 (local sensing) and 2-10 (remote sensing) show the connections for three series-connected units. These figures allow other configurations, e.g., two parallel-connected units or two series connected units, etc. to be easily deduced.

**CAUTION: For both parallel and series configurations, remove links between (COM S) and (COM OUT) terminals of all slaves to prevent damage to the unit and maintain system accuracy. Make sure to accurately follow Figures 2-7 through 2-10 for proper connection of the units.**

3. Connect all units to a common a-c power source.
4. Connect the load to the master power output terminals using wires rated for the total current and voltage of the system. For remote sensing use a twisted pair #22 AWG to connect OUT S to OUT and COMM S to COMM at the load (see Figure 2-8 for parallel or Figure 2-10 for series).
5. Connect monitoring/measuring devices to the master as shown in Figure 2-6.
6. Turn on all units, starting with the master. After the start-up sequence has ended, each unit should not be beeping, the POWER/FAULT/LIMIT lights should be green, and the MASTER/SLAVE lights should correctly identify master (green) and slaves (yellow).

7. If analog programming is to be used, connect the programming device to the master as shown in Figure 2-6.
8. If analog control is to be used, the multiple unit combination is ready for use. Operation of the multi-unit combination is identical to a standalone unit.

NOTE: When powering down the system, the master should be the last unit turned off.

9. If digital control is to be used, turn all units off.
  - a. Set power-up switch S3-2 to 0 (analog input disabled), Connect the GPIB or RS 232 cable from the host computer to the GPIB or RS 232 port on the BOP, respectively.
  - b. Turn on all units, starting with the master. After the start-up sequence has completed, verify that
    - all POWER/FAULT/LIMIT lights green,
    - MASTER/SLAVE lights correctly indicate master (green) and slave(s) (yellow)
    - It is recommended that the Output on-off pin at the Analog I/O port be disabled by sending OOTP:CONT OFF command to the master. This allows OOTP ON and OOTP OFF commands to control the output digitally via the host computer. The DIG. CTRL light on the master front panel will be on (green).
    - All OUTPUT ON lights for the slaves are on (green). The master OUTPUT ON light status is determined by either the state of the signal at Trigger port pin 2 or an OOTP command (see PAR. 3.3.8 for details).

### **2.8.5 RESTORING A UNIT TO STANDALONE OPERATION**

1. Turn off power to the master and all slaves.
2. Remove all interconnecting cables between units.
3. Perform steps a and b for each unit.
  - a. Access the power-up switches and reconfigure them as standalone (S2-1 set to 1, S2-2 through S2-5 set to 0)
  - b. Refer to PAR. 3.3.2.2 and reconfigure power-up switch S3 and S1 as desired.
  - c. After setting the power-up switches S1 through S3, turn on each unit for approximately 10 seconds to allow the unit to store the settings. Then turn off the unit and make connections as desired.

## SECTION 3 - OPERATION

### 3.1 GENERAL

This section explains how to operate the 1000 Watt BOP-G Power Supply. The power supply can be operated using either a) signals applied to the Analog I/O port control or b) digital commands via either the GPIB or RS 232 bus or c) a mixture of both.

Analog control (see PAR. 3.4) uses signals from the Analog I/O port to set the main channel mode (voltage/current), control the output voltage or current, set protection limits, and uses a signal applied to the Trigger port to control whether the output is on (enabled) or off (disabled).

Digital control (see PAR. 3.6) uses either the built-in GPIB (IEEE 488) (see PAR. 3.6.5) or RS 232 (see PAR. 3.7) interface to communicate with a remote computer. GPIB or RS 232 communication is via SCPI commands which afford full functionality of the BOP (see PAR. 3.7, Appendix A and Appendix B). Operation using digital control can be simplified by the use of the VISA driver (see PAR. 3.6.5).

### 3.2 POWER-UP SETTINGS

**CAUTION:** Before connecting a load, note that the unit will power-up with the configuration set by the power-up switches accessible through the top cover (see Table 2-2 for switch settings). Verify that these power-up settings are compatible with your load (see Figure 2-2 and Table 2-2 for switch settings).

To change to change load type, baud rate or Trigger port Remote on/off logic refer to PAR. 3.3.2.1; to change all other power-up settings listed below refer to PAR. 3.3.2.2.

In addition to the power-up settings determined by the switches accessed through the top cover, many unit parameters may be saved for the next power-up cycle using MEM:UPD commands (see PAR. B.12). When using MEM:UPD, it is recommended that the unit be tagged with the custom power-up configuration to avoid unexpected behavior upon power-up.

Factory default power-up switch settings (Figure 2-3) are **BOLD** (other choices are in italics):

- Load type **Active** (*Battery, Resistive*)
- Trigger port pin 2 remote on/off logic set for:  
**logic 1 or open = output enabled, logic 0 or short = output disabled**  
(*logic 0 = output enabled, logic 1 = output disabled*)

**NOTE:** By using the OUTP:CONT command (see PAR. B.15), the Trigger port pin can be set to put the unit in standby, or this input can be completely disabled if using OUTP command to control whether output is on or off.

- RS 232 Baud rate **9600** (*19.2K*)
- **Standalone** configuration (*Master, Slave*)
- Analog Control **enabled** (*disabled*)

- **Voltage mode** (*Current mode*)
- **internal control,  $\pm$  limit values at max ( $1.01 \times E_{Onom}$  or  $I_{Onom}$ )**  
*(internal control, +limit values at maximum ( $1.01 \times E_{Onom}$  or  $I_{Onom}$ ),  
 –limit values at minimum (box))*  
*(internal control, –limit values at maximum ( $1.01 \times E_{Onom}$  or  $I_{Onom}$ ),  
 +limit values at minimum (box))*  
*(External protection limits)*
- **GPIB address 6** (*0 to 30*)

All the above settings can be changed either by using the top cover-accessible switches while power is off, or by sending SCPI commands if using digital control.

### 3.2.1 CHANGING THE DEFAULT POWER-UP SETTINGS

The default power-up settings listed in PAR. 3.2 can be changed as follows:

1. To change Load type, Trigger port pin 2 remote on-off logic or RS 232 baud rate, refer to PAR. 3.3.2.1 for Reset Power-up.
2. To change all other power-up switch settings refer to PAR. 3.3.2.2 for normal power-up.

NOTE: All power-up settings can be changed by digital command, and if desired, the digitally changed setting can be saved for power-up using the MEM:UPD command (see PAR. B.12). However it is recommended that the unit be tagged with all settings saved for power-up to avoid unexpected behavior upon power-up.

### 3.3 POWER SUPPLY BASICS

The following paragraphs describe basic operation of the front panel controls and indicators (PAR. 3.3.1), how to turn the unit on, including how to change the power-up defaults (PAR. 3.3.2), and an explanation of the basic techniques and principles needed to operate the power supply.

When in Voltage mode, the power supply will (within the configured and rated limits) provide the programmed output voltage. Current is determined by the load, and cannot exceed the Current Protect limits. If the protect limit is reached, the POWER/FAULT/LIMIT LED light changes from green (power OK) to orange.

When in Current mode, the power supply will (within the configured and rated limits) provide the programmed output current. Voltage is determined by the load, and cannot exceed the Voltage Protect limits. If the protect limit is reached, the POWER/FAULT/LIMIT LED light changes from green (power OK) to orange.

#### 3.3.1 CONTROLS AND INDICATORS

Refer to Table 3-1 and Figure 3-1 for a description of front panel controls and indicators.



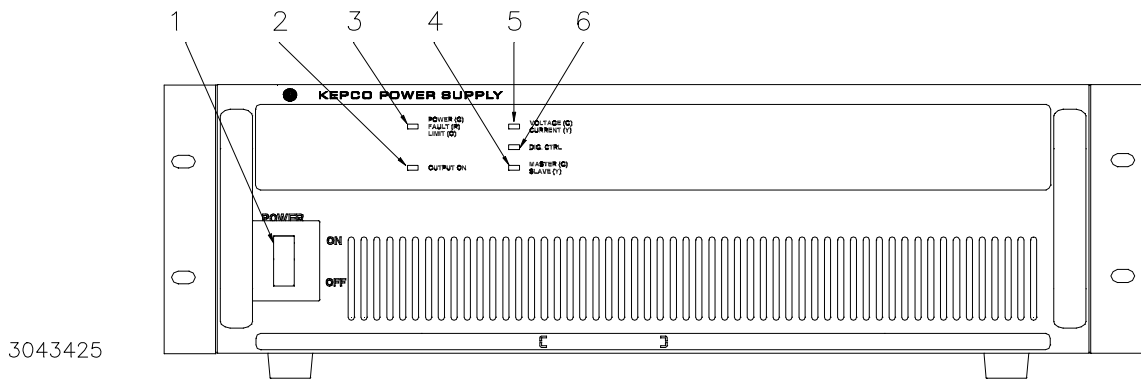

**FIGURE 3-1. BOP-G SERIES FRONT PANEL**

**TABLE 3-1. FRONT PANEL CONTROLS AND INDICATORS**

NUMBER (FIGURE 3-1)	CONTROL/INDICATOR	FUNCTION
1	POWER ON/OFF circuit breaker A7CB1	Applies source power to unit.
2	OUTPUT ON LED	Provides Output Status. Lights green for OUTPUT ON, not lit for output off.
3	Unit Status POWER/FAULT/LIMIT LED	Lights green for POWER good, lights red for FAULT, lights orange for LIMIT.
4	Configuration Type MASTER/SLAVE LED	Lights green for MASTER or Standalone, lights yellow for SLAVE. For multiunit configuration, this flashes (either green or yellow) to indicate unit is a master, and is looking for slaves. If flashing continues, refer to PAR. 3.8 for troubleshooting.
5	Mode of Operation VOLTAGE/CURRENT LED	Flashes during power-up while configuration is established. Lights green for VOLTAGE mode, lights yellow for CURRENT mode. If flashing continues, refer to PAR. 3.8 for troubleshooting.
6	DIG. CTRL LED	Lights green for digital control, not lit for Analog Control.

### 3.3.2 TURNING THE POWER SUPPLY ON

The status of the unit upon power-up depends on the configuration of the three power-up switches (see Figure 2-2 and Table 2-2). Each power-up switch has five segments. For convenience the switch settings are often given for all segments as e.g., 00110 indicates segments 5, 4 and 1 are off (0) and segments 2 and 3 are on (1). In other instances a particular segment (e.g., S3-5) is specified.

The reset power-up (PAR. 3.3.2.1) allows the power-up switches to establish 1) load type, 2) Remote On/off logic at Trigger port pin 2 and 3) baud rate. The reset power-up also resets all limits to the factory default condition (see PAR. B.145). The normal power-up (PAR. 3.3.2.2) establishes the operating mode of the unit, whether control will be analog or digital, whether the unit is standalone or part of a multi-unit configuration, and selects the GPIB address to be used (see Table 2-2 for details).

### 3.3.2.1 RESET POWER-UP

At power up, if the GPIB address switches (S1) are set to all ones (address 31), the unit does a reset power-up to establish the load type, baud rate and Remote On/Off logic of Trigger port pin 2. Reset power-up also causes the unit to reset all limits to the factory default configuration (see PAR. B.145) and override limits saved by MEM:UPD LIM command. If load type, baud rate and Trigger Port remote on/off logic do not need to be changed, refer to PAR. 3.3.2.2 for normal power-up.

1. With power off before Reset Power-up power-up, at the top cover, set GPIB address to 11111 (switches S1-1 through S1-5 set to 1) and set all S3 switches to 0.
2. Set S3 as follows to establish the load type upon power-up: S3-2 to 1 = Resistive Load, S3-3 to 1 = Active Load, S3-4 to 1 = Battery Load.
3. Set S3-1 to establish the baud rate for RS 232 operation: 1 = 19.2K, 0 = 9600.
4. Set S3-5 to 0 if desired to reverse the logic of the Remote On/Off signal at pin 2 of the External Trigger Port from the default (logic 1 = output enabled, logic 0 = output disabled) to logic 0 = output enabled, logic 1 = output disabled.
5. Do not change S2 settings.

**CAUTION: DO NOT repeatedly toggle the circuit breaker/switch as this may damage the unit.**

6. Set POWER ON/OFF circuit breaker/switch (1, Figure 3-1) on front panel to ON. If actuator does not lock when released, wait a few seconds before trying again. The circuit breaker is "trip-free" design; if overload exists, contacts cannot be held closed by actuator.
7. The unit will begin beeping on and off at equal intervals. Set POWER ON/OFF circuit breaker/switch on front panel to OFF and proceed to normal power-up (PAR. 3.3.2.2) to complete power-up configuration.

For subsequent power-up, unless it is necessary to change RS 232 baud rate, load type, or the logic at Trigger port pin 1, refer to PAR. 3.3.2.2 for normal power up (without resetting limits to defaults).

### 3.3.2.2 NORMAL POWER-UP

Power-up conditions are established by switches S1, S2 and S3 available from the top cover (see Table 2-2 and Figure 2-2). If either the load type upon power-up, RS 232 baud rate or the remote on/off logic at Trigger Port pin 2 needs to be changed, refer to Reset Power-up setup, PAR. 3.3.2.1. NOTE: Reset Power-up setup will reset the limits to factory default settings (overrides limit settings previously saved by MEM:UPD LIM command); Normal power-up leaves the limits unchanged.

1. With power off set switches S1, S2 and S3 as desired in accordance with Table 2-2.
  - a. Set S3 to establish power-up conditions per Table 2-2: either a) use one of 15 previously saved memory locations to establish power up conditions or b) Determine whether the main channel will be controlled by an analog signal at I/O port pin 11 or by digital commands, establish main channel Mode (Voltage/Current) per PAR. 3.3.9) and establish the protection limits (control of the limit channel) per par 3.3.10.

- b. Set S2 to select standalone or multiple unit operation.
- c. Set S1 with valid GPIB address from 0 to 30.

**CAUTION: DO NOT repeatedly toggle the circuit breaker/switch as this may damage the unit.**

2. Set POWER ON/OFF circuit breaker/switch (1, Figure 3-1) on front panel to ON. If actuator does not lock when released, wait a few seconds before trying again. The circuit breaker is “trip-free” design; if overload exists, contacts cannot be held closed by actuator.
3. Unit performs self-test upon power-up initialization. If the unit passes self-test, the POWER/FAULT/LIMIT light turns green and the unit is ready for operation; if it fails, the light turns red.

### 3.3.3 VOLTAGE AND CURRENT PARAMETERS

Table 3-2 defines the voltage and current parameters used in this manual and provides references to the SCPI commands and queries associated with the parameter.

### 3.3.4 VOLTAGE/CURRENT PROTECT SETTINGS

These values are the references for the complementary channels: voltage in current mode and current in voltage mode. The range for these values is between a minimum (box) value (see Figure 1-3) and 1% above the rated nominal value (see PAR. 3.3.5). If the unit is in voltage mode, it will enter current protect mode when the load demands more current and energy than permitted by the  $\pm$ current protect settings. Similarly, if the unit is in current mode, it will enter voltage protect mode if the load demands more voltage and energy than permitted by the  $\pm$ voltage protect settings. When the protect settings are exceeded, the protection channel limits the output current or voltage, the POWER/FAULT/LIMIT LED lights orange (LIMIT), and the power supply continues operation in the complementary mode of operation.

The BOP can be configured to program the protection settings using either a single command to set both protection channels to the same value, or separate commands that independently control positive and negative protections.

CURR:PROT (see PAR. B.29) sets both positive and negative current protections to the same value. Note that the CURR command, when sent to a unit operating in voltage mode, also sets both positive and negative current protections to the same value as set by CURR.

VOLT:PROT (see PAR. B.98) set both positive and negative voltage protections to the same value. The VOLT command, when sent to a unit operating in current mode, also sets both positive and negative voltage protections to the same value as set by VOLT.

CURR:PROT:POS (see PAR. B.35) and CURR:PROT:NEG (see PAR. B.33) are used to program independent settings for positive and negative current protection, respectively.

VOLT:PROT:POS (see PAR. B.104) and VOLT:PROT:NEG (see PAR. B.102) are used to program independent settings for positive and negative voltage protection, respectively.

#### 3.3.4.1 HIDDEN VOLTAGE AND CURRENT PROTECT LIMITS

The BOP employs two back-up channels which function as safety backups if a main channel fails. The backup channel limits are fixed and not user accessible. These limits are set to 5% over the nominal (rated) values for voltage or current. If the software limits for a main channel is

changed (PAR. 3.3.5.1), the corresponding protect channel limit is automatically changed to be 5% of the nominal (rated) value above the user-programmed software limit.

**TABLE 3-2. VOLTAGE AND CURRENT PARAMETER DEFINITIONS**

Term	Definition	To modify refer to PAR.
+E <sub>Onom</sub> -E <sub>Onom</sub>	The nominal (rated) output voltage of the unit determined by model; e.g. for a BOP 36-28G, ±E <sub>Onom</sub> is 36V.	N/A
+I <sub>Onom</sub> -I <sub>Onom</sub>	The nominal (rated) output current of the unit determined by model; e.g. for a BOP 36-28G, ±I <sub>Onom</sub> is 28A.	N/A
+Voltage -Voltage	<b>Voltage mode only.</b> Positive (+) and negative (-) output voltage values established by remote command. Range (+): 0 to +Voltage max Range (-): 0 to -Voltage min	B.88, B.98
+Voltage max -Voltage min	<b>Voltage mode only.</b> Maximum (positive) and minimum (maximum negative) voltage that can be set. Value (+): 0 to +E <sub>Onom</sub> Value (-): 0 to -E <sub>Onom</sub>	B.90, B.91, B.92, B.94
+Current Protect -Current Protect	<b>Voltage mode only.</b> Defines maximum (+) current and Minimum (maximum negative) (-) that unit can source or sink. Range (+): +Current Protect min to +Current Protect max Range (-): -Current Protect max to -Current Protect min	B.29, B.30, B.35, B.33, B.19
+Current Protect Max -Current Protect Min	<b>Voltage mode only.</b> Maximum setting for +Current Protect and Minimum (maximum negative) setting for -Current Protect. Value (+): +Current Protect min to (1.01 x +Current max) Value (-): -Current Protect max to (1.01 x -Current min)	B.37, B.38, B.41, B.39
Minimum (box) +Current Protect Min -Current Protect Max	<b>Voltage mode only.</b> Minimum (positive) setting for +Current Protect and maximum (maximum negative) setting for -Current Protect. Values of ±Current Protect between +Current Protect Min and -Current Protect Max (near zero) are not allowed. This zone (also referred to as the <b>minimum (box)</b> ) is automatically calculated by the BOP (see Figure 1-3).	N/A
+Voltage Protect -Voltage Protect	<b>Current mode only.</b> Maximum positive (+) and minimum (maximum negative) (-) voltage that can appear at the output. Range (+): +Voltage Protect min to +Voltage Protect max Range (-): -Voltage Protect max to -Voltage Protect min	B.98, B.99, B.104, B.102, B.88
+Voltage Protect Max -Voltage Protect Min	<b>Current mode only.</b> Maximum (positive) setting for +Voltage Protect and Minimum (maximum negative) setting for -Voltage Protect. Value (+): +Voltage Protect min to (1.01 x +Voltage max) Value (-): -Voltage Protect max to (1.01 x -Voltage min)	B.106, B.107, B.110, B.108
Minimum (box) +Voltage Protect Min -Voltage Protect Max	<b>Current mode only.</b> Minimum (positive) setting for +Voltage Protect and maximum (maximum negative) setting for -Voltage Protect. Values of ±Voltage Protect between +Voltage Protect Min and -Voltage Protect Max (near zero) are not allowed. This zone (also referred to as the <b>minimum (box)</b> ) is automatically calculated by the BOP (see Figure 1-3).	N/A
+Current -Current	<b>Current mode only.</b> Positive and negative output current established by remote command. Range (+): 0 to +Current max Range (-): 0 to -Current min	B.19, B.29
+Current max -Current min	<b>Current mode only.</b> Maximum (positive) and minimum (maximum negative) current that can be set. Value (+): 0 to +I <sub>Onom</sub> Value (-): 0 to -I <sub>Onom</sub>	B.21, B.25, B.22

### 3.3.5 MAXIMUM/MINIMUM PROTECTION LIMITS (SOFTWARE-CONTROLLED)

The  $\pm$  protection limits are programmable software limits that establish the maximum and minimum (maximum negative) allowable levels of output voltage in current mode and current in voltage mode. The default protection limits are 1% above  $E_{Omax}$  or 1% above  $I_{Omax}$ .

**CAUTION: When working with active loads, always adjust the BOP protection limits to be above the maximum values of voltage or current expected from the load. For example, when the BOP is operating in voltage mode sinking energy from a constant current type load, set the current protection limits of the BOP above the maximum current expected from the load.**

The protect channel limits are +V (voltage) Protect max, -V Protect min, +C (current) Protect Max and -C Protect min (see Table 3-2); these prevent the unit from delivering voltage or current that exceed these settings. In voltage mode the current protect channel is clamped to the limit value; in current mode the voltage protect channel is clamped to the limit value. Adjustment range is between a minimum (box) value (see Figure 1-3) and 1% above the nominal (rated) value.

The BOP can be configured to program the protection limits using either a single command to set both protection limits to the same value, or separate commands that independently control positive and negative protection limits.

CURR:PROT:LIM (see PAR. B.37) sets both positive and negative current protection limits to the same value.

VOLT:PROT:LIM (see PAR. B.106) set both positive and negative voltage protection limits to the same value.

CURR:PROT:LIM:POS (see PAR. B.41) and CURR:PROT:LIM:NEG (see PAR. B.39) are used to program individual settings for positive and negative current protection limits, respectively.

VOLT:PROT:LIM:POS (see PAR. B.110) and VOLT:PROT:LIM:NEG (see PAR. B.108) are used to program individual settings for positive and negative voltage protection limits, respectively.

#### 3.3.5.1 MAXIMUM ACCEPTED VOLTAGE OR CURRENT (MAIN CHANNEL SOFTWARE LIMITS)

The software limits for the main channels (+Voltage Max, -Voltage Min, +Current Max and -Current Min) are the maximum (positive) and minimum (Maximum negative) values allowable for voltage and current. The default software limits are determined by the model: the nominal (rated) values for voltage and current (e.g., 36V and 28A for the BOP 36-28G). These four values can be adjusted independently. For example, a BOP 36-28G, capable of delivering  $\pm 36V$  in voltage mode can be configured to allow voltage to be adjusted only from -1V to +15V by setting -Voltage Min to -1 and +Voltage Max to +15. To accomplish this via either GPIB or RS 232 ports send the following SCPI commands:

VOLT:LIM:POS 15	sets voltage positive limit to +15 volts
VOLT:LIM:NEG 1	sets voltage negative limit to 1 volt.

To ensure these settings are restored after a power cycle send MEM:UPD LIM and tag the unit with the new power-up configuration. To restore factory default limits and undo the limits saved by MEM:UPD LIM command, either perform a reset power-up (see PAR. 3.3.2.1) or digitally query the limit(s), then digitally change them as needed, (if desired, save for power-up using MEM:UPD LIM). Tag the unit with new power-up settings.

Similarly, a BOP 36-28G, capable of delivering  $\pm 28A$  in current mode can be configured to allow current to be adjusted from  $-0.5A$  to  $+10A$  by setting  $-Current$  Min to  $-0.5$  and  $+Current$  Max to  $+10$ . Adjustment range is between 0 and  $E_{Onom}$  for voltage and 0 and  $I_{Onom}$  for current. Note that these software limits are not the same as the Protect Limits described in PAR. 3.3.6. To accomplish this via either GPIB or RS 232 ports send the following SCPI commands:

CURR:LIM:POS 10	Sets current max limit to 10 Amperes.
CURR:LIM:NEG 5	Sets current min limit to 0.5 Amperes.

To ensure these settings are restored after a power cycle send MEM:UPD LIM and tag the unit with the new power-up configuration. To restore factory default limits and undo the limits saved by MEM:UPD LIM command, either perform a reset power-up (see PAR. 3.3.2.1) or digitally query the limit(s), then digitally change them as needed, (if desired, save for power-up using MEM:UPD LIM). Tag the unit with new power-up settings.

The main channel software limit values can be lowered (closer to zero) by the user, e.g., to prevent inadvertent damage to a specific circuit under test. When the maximum/minimum values are lowered, the unit will not accept values that exceed the new software limits. The main channel software limits are always in effect, for both analog control and digital control. If the user attempts to program a value that exceeds the software limit using a digital command, the command is considered invalid and is disregarded: a 120 error is produced. If analog control is enabled, the output is clamped to the software limit for programmed values higher than the software limit.

**If main channel software limits are changed from the default, the protection limits must be changed to correspond to the new software limits (see PAR. 3.3.6).** As an example, changing  $+Voltage$  Max and  $-Voltage$  Min of a BOP 36-28G to  $\pm 3V$ , respectively, causes the unit to behave as if it was a BOP 3-28G. In this case it is important to change the  $+V$  Protect Max and  $-V$  Protect Min limits (e.g., to  $\pm 3.3V$ , respectively) so that the load is protected when operating in Current Mode. This is done by sending the following command.

VOLT:PROT:LIM 3.3	This sets both limits to 3.3 volts.
-------------------	-------------------------------------

It is also possible to establish different values for positive and negative limits as follows;

VOLT:PROT:LIM:POS 3.3	This sets the positive limit to 3.3 volts.
VOLT:PROT:LIM:NEG 2.9	This sets the negative limit to 2.9 volts.

When different values for positive and negative limits are set as above, Sending the command VOLT 3.3 or VOLT:PROT 3.3 sets the positive protection to 3.3 and the negative protection to 2.9 without reporting an error. Sending VOLT:PROT? causes the unit to return 3.3,2.9, indicating the positive protection is set to 3.3 Volts and the negative protection is set to 2.9 Volts. Sending VOLT:PROT:NEG 3.3 will not change the negative protection setting and will place a "Voltage Out of Range" error into the error queue.

To ensure these settings are restored after a power cycle send MEM:UPD LIM and tag the unit with the new power-up configuration. To restore factory default limits and undo the limits saved by MEM:UPD LIM command, perform a reset power-up (see PAR. 3.3.2.1).

### 3.3.6 DETERMINING HOW THE UNIT RESPONDS WHEN OUTPUT IS OFF (LOAD TYPE)

The BOP supports three Load Type selections (see Table 3-3) which determine how the power supply responds when the output is off: ACTIVE, RESISTIVE and BATTERY. These selections are designed to provide proper operation with different load types. It is important to note that the Load Type selection does not affect the settings of the power supply for ON state; it only affects the main internal reference level and the protection levels during the OFF state. Load type is selected by performing a Reset Power-up (see PAR. 3.3.2.1) or by using the digital OUTP:MODE command (see PAR. B.17).



**For inductive loads, and especially superconducting magnet type loads, the inherent offset of the BOP in the OFF state may generate significant current in the circuit. Two properly rated external switches must be installed for safety: one in series between the power supply and the magnet, and the other in parallel with the magnet. Once the BOP front panel display reads 0V, 0A, close the parallel switch, then open the series switch before removing or installing connections between BOP and load. To restore normal operation, first close the series switch, then open the parallel switch.**

**ACTIVE.** Active mode (default setting) is necessary for the power supply to function properly and safely with inductive loads and constant-current-type active electronic loads. Active mode can also be used with resistive loads. Table 3-3 indicates how the power supply responds to a command to go from Output ON to OFF. When the output is disabled, the unit is set to voltage mode, voltage is set to zero and both current protect and voltage limit are set to maximum. When the unit is enabled, the pre-existing settings for voltage, current protect and voltage limit are restored.



**For both inductive loads and constant-current-type active electronic loads when the BOP output is set to OFF, a path is provided for absorbing either the energy accumulated in the reactance of the load during the ON state, or energy delivered by an electronic load. This prevents damage to the load and power supply as well as providing safety for the user. However, In addition to the built-in safety features, constant-current-type active electronic loads must be adjusted to zero and voltage and current measurements at the output must read 0V, minimum current, before handling the power supply-to-load connections.**

**RESISTIVE.** This mode, as the name suggests, is useful for resistive loads. Table 3-3 indicates how the power supply responds to a command to go from Output ON to OFF.

**WARNING**

Accessing the BOP after the output is disabled in BATTERY mode is hazardous because (1) high current arcing is possible and (2) either the external battery voltage, or the voltage ( $\pm$ Voltage Protection max) on the BOP output terminals may be dangerous. Therefore, for battery and constant-voltage-type active electronic loads it is recommended that two properly rated external switches be installed for safety: one in series with the battery, and one across the BOP output. After the unit is set to OFF, first open the switch in series with the battery, then close the switch across the BOP output to ensure safety before handling BOP connections. When connecting the battery, the switch across the output should be opened after the connections are complete and then the switch in series with the battery should be closed. If the constant-voltage-type active electronic load is adjusted to zero before handling the power supply-to-load connections, only the switch across the BOP output is required.

**BATTERY.** This mode is necessary for the power supply to function properly and safely with either battery or constant-voltage-type active electronic loads. This mode prevents the battery from discharging during the OFF state. When the output is disabled (set to OFF), the BOP will go to current mode, current will be set to the calibrated zero value, with voltage protect and current limit set to maximum. In this way the battery will not be discharged while the output is OFF. However, even if properly calibrated, the zero current has a tolerance of  $\pm 0.01\%$  of nominal rated current. Therefore the battery will be very slowly charged or discharged by this non-zero current value, depending on its polarity. . For constant-voltage-type active electronic loads this mode stops energy flow during the OFF state. Table 3-3 indicates how the power supply responds to a command to go from Output ON to OFF.

**TABLE 3-3. POWER SUPPLY BEHAVIOR WHEN OUTPUT IS SET TO OFF**

LOAD TYPE SETTING	If unit was in Voltage Mode when output OFF command issued.	If unit was in Current Mode when output OFF command issued.
ACTIVE	<ul style="list-style-type: none"> <li>• Unit remains in voltage mode.</li> <li>• Voltage set to zero.</li> <li>• Both <math>\pm</math> Current Protect set to maximum.</li> <li>• Both <math>\pm</math> Voltage Limit remain at maximum.</li> </ul>	<ul style="list-style-type: none"> <li>• Unit set to voltage mode.</li> <li>• Voltage set to zero.</li> <li>• Both <math>\pm</math> Current Protect remain at maximum.</li> <li>• Both <math>\pm</math> Voltage Limit set to maximum.</li> </ul>
RESISTIVE	<ul style="list-style-type: none"> <li>• Unit remains in voltage mode.</li> <li>• Voltage set to zero.</li> <li>• Both <math>\pm</math> Current Protect set to minimum box values.</li> <li>• Both <math>\pm</math> Voltage Limit remain at maximum.</li> </ul>	<ul style="list-style-type: none"> <li>• Unit remains in current mode.</li> <li>• Current set to zero.</li> <li>• Both <math>\pm</math> Voltage Protect set to minimum box values.</li> <li>• Both <math>\pm</math> Current Limit remain at maximum.</li> </ul>
BATTERY	<ul style="list-style-type: none"> <li>• Unit set to current mode.</li> <li>• Current set to zero.</li> <li>• Both <math>\pm</math> Voltage Protect remain at maximum.</li> <li>• Both <math>\pm</math> Current Limit set to maximum.</li> </ul>	<ul style="list-style-type: none"> <li>• Unit remains in current mode,</li> <li>• Current set to zero.</li> <li>• Both <math>\pm</math> Voltage Protect set to maximum.</li> <li>• Both <math>\pm</math> Current Limit remain at maximum.</li> </ul>



### **3.3.6.1 BATTERY CHARGING/DISCHARGING USING THE BOP**

The BOP can charge/discharge batteries using either voltage mode or current mode. The recommended configuration is to use voltage mode with remote sense connections.

#### **3.3.6.1.1 BATTERY OPERATIONS USING VOLTAGE MODE**

Using voltage mode with remote sensing connections provides more accurate voltage control of the battery, avoiding the effects of both parasitic voltage drops on the connection wiring and the battery's internal resistance.

The BOP output voltage is set to the desired battery voltage and current limit is set to the required charging current value. The BOP will go into current limit, charging the battery with a constant current. As the battery's voltage nears the BOP voltage setpoint, the BOP will switch to voltage mode when the battery voltage reaches the "capture" range of the BOP voltage loop.

The voltage loop has a resolution of 14 bits (either local or digital control) versus 12-bit resolution for the voltage-limit loop. Consequently, the voltage loop accuracy (0.03% of rated output) is ten times better than voltage-limit loop accuracy.

The charging process continues as long as the voltage remains within the "capture" range of the voltage mode. Charging current decreases gradually towards the battery's leakage value. This configuration eliminates the dithering (alternating between current and voltage limit mode) induced by the battery's internal resistance. The only drawback to using voltage mode is that the charging current limit resolution/ accuracy is 12-bit/ 0.5%, versus 14-bit/ 0.1% for current mode.

A similar process will take place when discharging the battery. By setting the BOP voltage to a lower level than the battery's voltage value, the battery discharge current will be established by the negative current limit setpoint. The discharging value can be different than for charging by using independent limits to set different values for positive and negative current limit.

#### **3.3.6.1.2 BATTERY OPERATIONS USING CURRENT MODE**

The following description explains the drawbacks of using current mode for battery operations. In voltage mode the voltage feedback comes from the remote sense terminals (OUT\_S, COM\_S). However In current mode the voltage limit feedback comes from the local output monitoring terminals (OUT\_MON & COM\_MON). This protects the load against excessive voltage if a sensing connection is lost while in current mode.

The result is that if current mode is used to charge a battery (with or without local sensing), the charging process will stop (putting the BOP into voltage limit mode) at a voltage lower than the voltage limit set value. This is due to a) the parasitic voltage drop on the connecting wiring and b) the internal battery's resistance. The BOP, now in voltage-limit mode, senses that battery voltage is lower than the voltage-limit set value and switches back to current mode. From this point, the BOP will change between current mode and voltage-limit mode (dither). The dithering rate will depend on the battery's internal impedance, the charging set current, the parasitic connection's resistance and the time it takes the BOP to switch between modes. In some cases, for a parasitic voltage drop equal to, or less than, the accuracy of the voltage limit loop (0.3% of rated output), the dithering will stop. While dithering between current mode and voltage limit mode, the front panel meter will show an approximate average output voltage which will be higher than the voltage limit set value.

Discharging the battery using current mode operation must be carefully monitored. If the voltage limit is unchanged and the current is set to a negative value, the battery will discharge at the BOP current setpoint value. If the process is not monitored and stopped, the battery will be com-

pletely depleted. The BOP will even try to reverse-charge the battery to the negative voltage limit value. Therefore, if current mode is chosen, it is recommended that independent limits be used, and the negative voltage limit be set to minimum (0.2% of rated output voltage).

If the positive voltage-limit is set lower than the battery's voltage, then more than one loop will try to control the output. Consequently, the battery will discharge at a much higher current than the BOP current setpoint. As previously described, if not monitored and the process stopped, the discharge will completely deplete the battery.

If current mode is needed, Kepco can modify the unit to establish the voltage limit feedback loop to use the Sense terminals, rather than the Monitor terminals. The modified unit behaves similar to that described for voltage mode except that voltage accuracy is 12-bit/ 0.3%, versus 14-bit/ 0.1% for voltage mode. Contact Kepco Sales for further details.

### **3.3.7 EXTERNAL LIMITS**

These limits are external analog signals which are converted within the BOP to digital signals that program the protection channels only: current protect in voltage mode and voltage protect in current mode. The range of each analog input signal is +1V to +10V, corresponding to a range for clamping the output between minimum, 10% of nominal (positive and negative), to +max/–min of nominal rating. Refer to PAR. 3.4.2 for details on implementing external limits.

Table 3-2 explains the effect that these limits have in both voltage and current mode, and references the corresponding paragraph for changing the parameter.

### **3.3.8 ENABLING/DISABLING DC OUTPUT POWER**

The behavior of the unit when disabled depends on the Load Type setting (see PAR. 3.5.5 and Table 3-3 for details). There are four ways to disable the output:

1. Using Remote Shutdown pin 2 (referenced to pin 1) of the Protect Ext. port. This requires the unit to be turned off, then on in order to restore operation (see PAR. 3.3.8.1).
2. Using Remote On-Off at pin 2 (referenced to pin 1) of the Trigger port which sets the output to off (disabled) or on (enabled) by toggling a signal applied to the Trigger port (see PAR. 3.3.8.2).
3. Using Remote On-Off at pin 2 (referenced to pin 1) of the Trigger port to disable the output and the digital command OUTP ON to enable the output (see PAR. 3.3.8.3).
4. Using digital commands OUTP OFF and OUTP ON to disable and enable the output (see PAR. 3.3.8.4).

#### **3.3.8.1 REMOTE SHUTDOWN**

Functionality of a standalone unit can be shut down using a remote signal applied to the PROTECT EXT. PORT as shown in Figure 3-2 or 3-3. Functionality of a multiple unit configuration (parallel, series or series-parallel) can be shut down by applying a remote signal to the master PAR/SER PROTECTION PORT as shown in Figure 3-2 or 3-4. When the signal is momentarily active (minimum 100 microseconds), power transfer between input and output is stopped (both input and output internal modules are shut off). This condition is latched and shuts down unit functionality. The unit remains powered, but no output is available and the front panel POWER/FAULT/LIMIT LED will turn red (fault). The unit must be powered off, then on again to

restore normal operation. This feature can be used a "panic" control or as an interlock shut down for a system with other equipment.

For multiple unit configurations, automatic shutdown upon accidental removal of the cable at the Master PAR/SER IN PROTECT PORT can be implemented with a simple internal modification. Contact Kepeco for details.

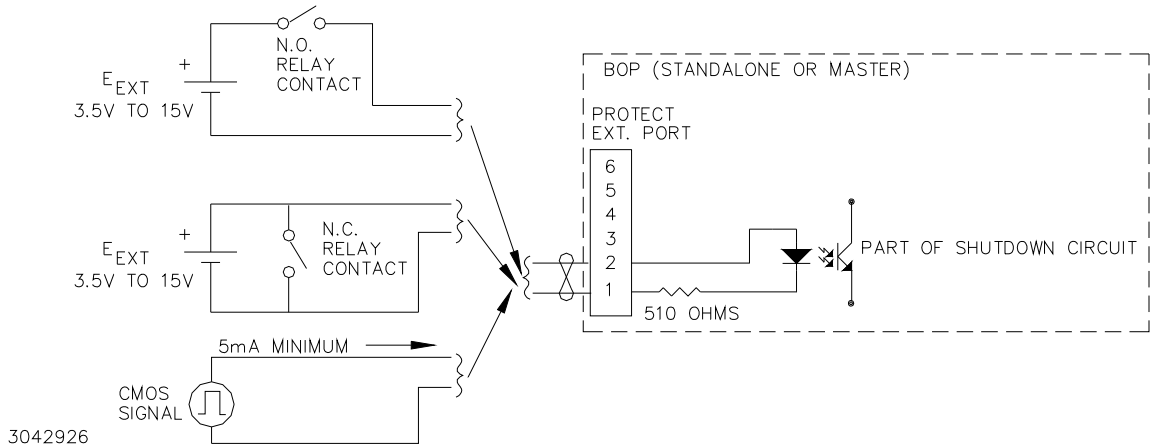

**FIGURE 3-2. REMOTE SHUTDOWN USING EXTERNAL POWER, STANDALONE OR MULTIPLE UNITS**

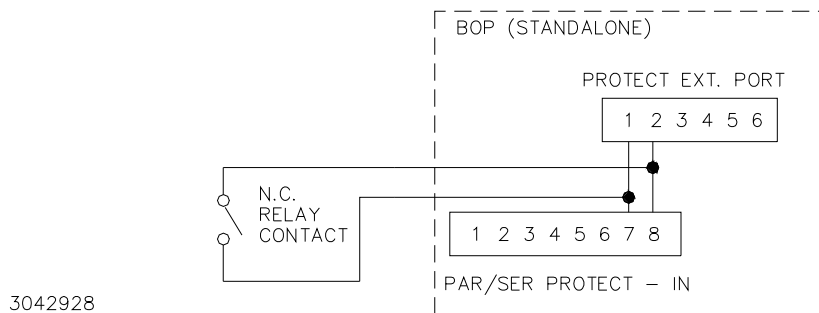

**FIGURE 3-3. REMOTE SHUTDOWN USING INTERNAL POWER, STANDALONE UNITS**

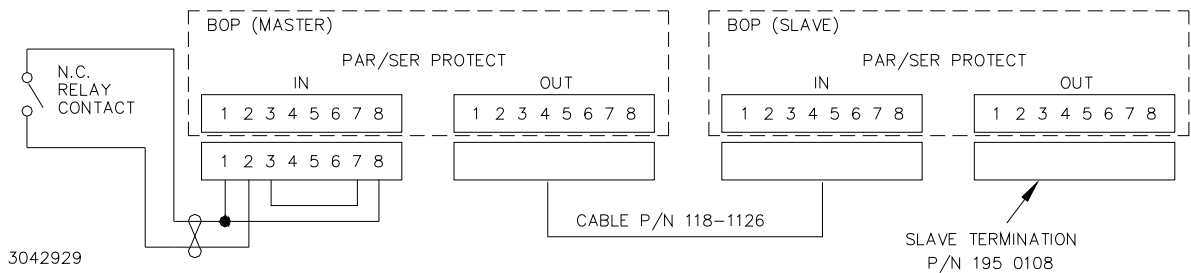

**FIGURE 3-4. REMOTE SHUTDOWN USING INTERNAL POWER, MULTIPLE UNITS,**

### 3.3.8.2 REMOTE ON-OFF USING TRIGGER PORT PIN 2

A standalone unit or a multiple unit configuration (parallel or series) can be set to output on (enabled) or off (disabled) by applying a remote signal to the TRIGGER PORT as shown in Figure 3-5. For multiple unit configurations this signal must be applied to the master.

The factory default condition, established by the Reset Power-up configuration (see PAR. 3.3.2.1) is: when the signal is active (Logic 0 or short-circuit referenced to logic GND (pin 1), the output is set to off after a maximum delay of 200 milliseconds and the front panel OUTPUT indicator goes off. Logic 1 (TTL or 5V-CMOS) or open sets the output to ON (output enabled) and the OUTPUT indicator goes on.

This logic can be reversed so that logic 1 sets output off, logic 0 sets output on, by setting S3-5 to off (0) as directed during the Reset Power-up (PAR. 3.3.2.1).

### 3.3.8.3 REMOTE ON-OFF USING TRIGGER PORT (OFF) AND DIGITAL COMMAND (ON)

This method of controlling the output uses Trigger Port pin 2 to turn the output off, and the OUP ON command to turn the output on (see Figure 3-5). This method requires that OUP:CONT STANDBY (see PAR. B.15) be sent first. OUP:CONT STANDBY allows a logic 0 (or short-circuit) pulse (100 $\mu$ S minimum) on pin 2 of the trigger port to turn off the output. A logic 1 or open circuit at Trigger port pin 2 has no effect on the output. Sending OUP ON turns the output on.

### 3.3.8.4 REMOTE ON-OFF USING DIGITAL COMMANDS

This method uses OUP ON and OUP OFF commands to control the output. This requires that OUP:CONT OFF command (see PAR. B.15) be sent first, disabling the Trigger port pin 2. (If OUP:CONT OFF is not sent, the state of Trigger port pin 2 will override the digital commands.) To save the OUP:CONT state for power-up, send MEM:UPD INT and tag the unit with the new power-up configuration

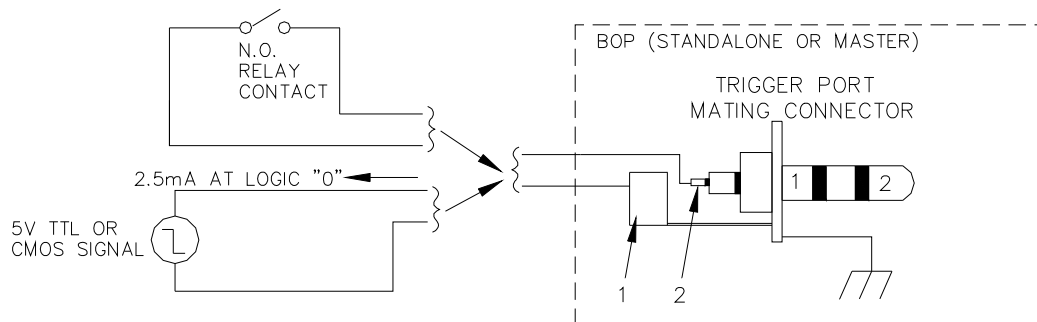

3042930

FIGURE 3-5. REMOTE ON-OFF, STANDALONE OR MULTIPLE UNITS

### 3.3.9 SETTING MAIN CHANNEL MODE (VOLTAGE OR CURRENT)

When the unit is turned on, the main channel mode is determined by the power-up switches.

- If S3 is set to 00000 the mode is determined by the status of pin 2 of the Analog I/O port (see Table 2-11). Applying a TTL logic 1 (or open circuit) programs the unit to voltage mode. Applying a TTL logic 0 (or short circuit) programs the unit to current mode.
- If S3 is set to 0nnnn (where nnnn = binary number from 1 (0001, where S3-1 = 1) to 15 (1111), unit turns on with the mode previously saved in the selected location, and may be either voltage or current mode.
- If S3 is set to 1xxxn (xxx = set as desired; if n = 0, unit is set to current mode, if n = 1, unit is set to voltage mode.

Once the unit is powered up, main channel mode can be controlled by the FUNC:MODE command (see PAR. B.45).

- Sending FUNC:MODE VOLT sets the unit to voltage mode and sending FUNC:MODE CURR sets the unit to current mode.
- Sending FUNC:MODE EXT allows the mode to be determined by the status of pin 2 of the Analog I/O port (see Table 2-11).

### 3.3.10 PROTECTION LIMITS

When the unit is turned on the protection limits are determined by the power-up switches:

- If S3 is set to 00000 the protection limits are controlled by the pins 5, 6, 13 and 14 of the Analog I/O port (see Table 2-11).
- If S3 is set to 100xx (x = set as desired, S3-3 and S3-4 = 0, S3-5 = 1), the protection limits are controlled by the pins 5, 6, 13 and 14 of the Analog I/O port (see Table 2-11).
- If S3 is set to 0nnnn (where nnnn = binary number from 1 (0001, where S3-1 = 1) to 15 (1111), unit turns on with the limits previously saved in the selected location.
- If S3 is set to 101xx (x = set as desired, S3-3 = 1, S3-4 = 0, S3-5 = 1), -V Protect Max and -C Protect Max are internally set to maximum (1.01 x nominal (rated) values. +V Protect Max and +C Protect Max are Internally set to min. (box).
- If S3 is set to 110xx (x = set as desired, S3-3 = 0, S3-4 = 1, S3-5 = 1), +V Protect Max and +C Protect Max are internally set to maximum (1.01 x nominal (rated) values. -V Protect Max and -C Protect Max are Internally set to min. (box).
- If S3 is set to 111xx (x = set as desired, S3-3 = 1, S3-4 = 1, S3-5 = 1), ±V Protect Max and ±C Protect Max are internally set to maximum (1.01 x nominal (rated) values.

Once the unit is powered up, main channel mode can be controlled by the CURR:PROT:MODE (see PAR. B.31) and VOLT:PROT:MODE (see PAR. B.100) commands.

- Sending VOLT:PROT:MODE FIXED allows the voltage protect limits to be controlled by VOLT:PROT:LIM commands and sending CURR:PROT:MODE FIXED allows the current protect limits to be controlled by CURR:PROT:LIM commands

- Sending VOLT:PROT:MODE EXT allows the voltage protect limits to be controlled by pins 6 and 14 of the Analog I/O port. Sending CURR:PROT:MODE EXT allows the current protect limits to be controlled by pins 5 and 13 of the Analog I/O port.
- Sending VOLT:PROT:MODE LESS allows the voltage protect limits to be controlled by the lesser absolute value between that selected by the digital VOLT:PROT:LIM commands and the analog voltage on pins 6 and 14 of the Analog I/O port (see PAR. 3.4.2.1 for details).
- Sending CURR:PROT:MODE LESS allows the current protect limits to be controlled by the lesser absolute value between that selected by the digital CURR:PROT:LIM commands and the analog voltage on pins 5 and 13 of the Analog I/O port (see PAR. 3.4.2.1 for details).

### 3.4 ANALOG REMOTE MODE PROGRAMMING

The recommended method for asserting Analog control requires that the unit be powered up with power-up switches S3-1 through S3-5 set to 00000 (see Figure 2-2 and Table 2-2). This sets up the following:

- The main channel is controlled by the external reference at pin 11 of the Analog I/O port (see Table 2-11).
- The limit channels are controlled by the reference voltages at pins 5, 6, 13 and 14 of the Analog I/O port (only two pins are active, determined by which limit channel is active) (see Table 2-11).
- The mode (voltage/current) is determined by the state of pin 2 of the Analog I/O port (see Table 2-11).

Analog mode may be configured remotely using either VOLT:MODE EXT (PAR. B.96) or CURR:MODE EXT (PAR. B.27) to enable the external reference in both voltage and current mode. Digital programming may be restored remotely by sending either VOLT:MODE FIX (PAR. B.96) or CURR:MODE FIX (PAR. B.27).

Pins of the Analog I/O port can also be used selectively to control the unit if the unit is powered up with power-up switches S3-2 and S3-5 set to on (see Figure 2-2 and Table 2-2). This allows the other S3 switches to selectively establish the following:

- Establish voltage or current mode (PAR. 3.3.9).
- Control the main channel using the BOP as a power amplifier (PAR. 3.4.1).
- Establish the protection limits (PAR. 3.4.2).

#### 3.4.1 CONTROLLING THE OUTPUT USING THE BOP AS A POWER AMPLIFIER

The BOP can function as a power amplifier by means of the External Reference input at the Analog I/O port. This analog signal controls the main channel of the BOP. To use the BOP as a power amplifier see the following instructions for using the external reference for establishing the maximum full scale output.: PAR. 3.4.1.1 for fixed gain, PAR. 3.4.1.2 for variable gain.

### 3.4.1.1 FIXED GAIN USING EXTERNAL REFERENCE CONTROL

The main channel of the BOP, voltage in voltage mode, and current in current mode, can be controlled by an external reference voltage, 0 to  $\pm 10V$  applied at pin 11, referenced to pin 10, of the Analog I/O port. The input impedance for this signal is 20K ohms.

**NOTE: Power-up switch S3 must either be set to 00000 or S3-2 and S3-5 must be set to 1 (on) prior to power-up, otherwise the analog reference signal applied to Analog I/O Port pin 11 will have no effect.**

When the external reference is used, the BOP functions as a power amplifier, amplifying the external reference at pin 11 to produce the output.

The nominal (inherent) voltage gain of each model is calculated by  $(G_{NOM-V}) = E_{ONOM} / E_{REF}$  and nominal (inherent) current gain is  $(G_{NOM-I}) = I_{ONOM} / E_{REF}$ . Thus the nominal gain is the ratio between the nominal (rated) voltage or current ( $E_{ONOM}$  or  $I_{ONOM}$ ), and the external reference ( $E_{REF}$ ) used to produce that output.

So for an external reference of  $\pm 10V$ , the nominal voltage gain  $(G_{NOM-V}) = E_{NOM-V}/10$ , e.g., the voltage gain of a BOP 36-28G is  $36/10 = 3.6$ . The nominal current gain  $(G_{NOM-I})$  is  $I_{NOM-V}/10$ , e.g., the current gain of a BOP 36-28G is  $28/10 = 2.8$ .

The external reference voltage may be d-c, a-c, or a combination of a-c plus d-c. The maximum frequency of an a-c signal should be below the inherent frequency response of the BOP (1KHz for voltage, 800Hz for current (see Table 1-2). For parallel or series combinations, the frequency response is reduced as specified in the instruction manual included with the cable kit. A frequency that exceeds the bandwidth of the BOP will cause the output to be distorted.

For linear response (input vs. output) the software limit (see 3.3.5) should be set to nominal and the maximum peak value (d-c plus a-c) of the reference signal must not exceed  $\pm 10V$ . If the input signal exceeds the limit value (either  $\pm 10V$  if the software limit is set to nominal, or a lesser voltage for a user-determined software limit) clipping of the output voltage or current to the limit will occur.

**NOTE:** If the system limits have been modified (PAR. 3.3.5), the output of the power supply will never exceed the modified system limits. E.g., for a BOP 36-28G, if the system voltage limit is modified to  $\pm 18V$ , applying a positive analog voltage to pin 11 that starts at zero and rises to +10V causes the output to rise from zero and reach +18V when the external reference reaches +5V. The output stays at +18V while the reference increases from +5V to +10V since the system voltage limits for this example are  $\pm 18V$ .

The command sequence that can be used is:

FUNC:MODE VOLT	Sets unit to voltage mode.
VOLT:LIM 18	Sets main channel (voltage) software limits to $\pm 18V$ .
CURR:PROT 20	Sets protection level to $\pm 20A$ .

To restore all the above settings for power up, send \*SAV3. This saves the settings to memory location 3 (locations 1 through 15 can be used to establish initial power-up conditions). Set power-up switch S3 to 00011 when performing a normal power-up (PAR. 3.3.2.2) to restore the saved settings upon power up: main channel set to voltage, voltage limits set to  $\pm 18V$  and current protection set to  $\pm 18A$ .

The voltage limit setting can also be saved by sending MEM:UPD LIM (see PAR B.12) and tagging the unit with the new power-up settings. The factory default limits can be restored by performing a reset power-up (PAR. 3.3.2.1) which overrides the limits previously set by MEM:UPD LIM.

NOTE: If the system limits have been modified (PAR. 3.3.5), the output of the power supply will never exceed the modified system limits.

### 3.4.1.2 VARIABLE GAIN USING EXTERNAL REFERENCE LEVEL

The BOP can function as a variable gain power amplifier similar to the fixed (inherent or nominal) gain amplifier for both voltage and current modes, as described in PAR. 3.4.1.1. The user can determine a new (lower) full scale output value for the  $\pm 10V$  reference level (applied at pin 11, referenced to pin 10, of the Analog I/O port) by configuring the Reference input as follows:

**NOTE: Power-up switch S3 must either be set to 00000 or S3-2 and S3-5 must be set to 1 (on) prior to power-up, otherwise the analog reference signal applied to Analog I/O Port pin 11 will have no effect.**

For an external reference of  $\pm 10V$ , the nominal voltage gain ( $G_{NOM-V}$ ) of a BOP 36-28G is  $36/10 = 3.6$ . If the new full scale voltage for 10V is set to 29V, the voltage gain is changed from 3.6 to  $29/10 = 2.9$ . The gain can be changed only using digital CURR:MODE (see PAR. B.27) and VOLT:MODE (see PAR. B.96) commands, but the output is controlled by the external reference signal.

Once the feature is configured, the new full scale value is entered by changing the active setting value of the main channel. This determines the full scale output to be produced by a 10V external reference. The command sequence that can be used is:

FUNC:MODE VOLT	Sets unit to voltage mode.
VOLT:MODE GAIN	Enables gain mode of operation.
VOLT 29	For 10V at Analog I/O pin 11, output level set to 29V.
CURR:PROT 28.3	Sets protection level to maximum.

To restore the above settings for power up, send \*SAV1. This saves the settings to memory location 1 (locations 1 through 15 can be used to establish initial power-up conditions). Set power-up switch S3 to 00001 when performing a normal power-up (PAR. 3.3.2.2) to restore the saved settings upon power up: output set to voltage (gain) mode of operation with gain set to 2.9.

The gain in voltage mode is  $G_V = V_{SET}/10$  where  $V_{SET}$  is the desired full scale voltage (in Volts) entered at the front panel.

The gain in current mode is  $G_A = I_{SET}/10$  where  $I_{SET}$  is the desired full scale current (in Amperes) entered at the front panel.

NOTE: If the system limits have been modified (PAR. 3.3.5), the output of the power supply will never exceed the modified system limits.

The adjustment range of the gain is between zero and 100% of the nominal gain, but 10% is recommended as the minimum value.



### 3.4.2 EXTERNAL PROTECTION LIMITS

External protection limits are established upon power-up by switches S3-3 and S3-4. Once the unit is powered up, the signals at the analog I/O port and the digital commands can be used to control the protection limits. Refer to Table 2-2 and PAR 3.3.10 for details. External protection limits can also be configured remotely by sending either CURR:MODE:PROT EXT (see PAR. B.31) or VOLT:MODE:PROT EXT (see PAR. B.100). The following paragraphs explain the operation of the analog signals assuming that they have been enabled.

**Only two of the four LIM\_EXT signals are active at a time**, affecting the complementary protect channel:  $\pm$ current protect limit for voltage mode and  $\pm$ voltage protect limit for current mode. A voltage between +1V and +10V at the following pins (referenced to Ground, pin 12) will control the corresponding protection parameter between 10% of the nominal value (see Figure 1-3) and the corresponding positive or negative nominal full scale value.

- **-I\_LIM\_EXT (pin 5)** - This +1V to +10V analog signal sets the negative current protect limit from 10% of the nominal value to -full scale current. +10V corresponds to rated minimum (maximum negative) current (e.g., for BOP 36-28G, +10V sets negative current limit to -28A).
- **-V\_LIM\_EXT (pin 6)** - This +1V to +10V analog signal sets the negative voltage protect limit from 10% of the nominal value to -full scale voltage. +10V corresponds to rated minimum (maximum negative) voltage (e.g., for BOP 36-28G, +10V sets negative voltage limit to -36V).
- **+I\_LIM\_EXT (pin 13)** - This +1V to +10V analog signal sets the positive current protect limit from 10% of the nominal value to full scale current. +10V corresponds to rated maximum current (e.g., for BOP 36-28G, +10V sets positive current limit to +28A).
- **+V\_LIM\_EXT (pin 14)** - This +1V to +10V analog signal sets the positive voltage protect limit from 10% of the nominal value to full scale voltage. +10V corresponds to rated maximum voltage (e.g., for BOP 36-28G, +10V sets positive voltage limit to +36V).

The maximum frequency of an a-c signal used for the external protection limit must be at least 10 times lower than the sampling rate of the external signal (10Hz), resulting in a bandwidth of 1Hz.

The external programming circuit must be able to sink 0.15mA maximum provided by the BOP. When the input is an open circuit, the corresponding input signal automatically goes to 20% above the nominal protection limit, but internally the protection value is clamped to 1.01 of nominal.

#### 3.4.2.1 USING LESSER OF DIGITAL VS. ANALOG (EXTERNAL) LIMITS

The BOP provides the ability to automatically choose the lesser absolute value between the external limits (applied to Analog I/O port pins 5, 6, 13 and 14) and the limits established by a digital command. This feature is accessible through digital control and can be restored upon power-up using a saved location.

For example, with a BOP 50-20G, the maximum limit value in current mode can be set to 20V using the digital interface, but the limits can be controlled by the analog limit signals applied to pins 6 and 14 of the analog I/O port. However, if the signals at pins 6 or 14 exceed 4V (10V = full scale or 50V, 4V is 2/5 of full scale = 20V), the digital limit will take effect and prevent the limit from exceeding 20V. To implement this send the following commands:

VOLT:PROT 10	Sets the positive and negative protection to 10 volts.
VOLT:PROT:MODE LESS	Allows protect limit to be automatically selected from either 1) the external analog voltage applied to the Analog I/O port or 2) 10V set by VOLT:PROT 10. Whichever limit has a lower absolute value (closest to zero) has effect.
FUNC:MODE CURR	Sets the output to current mode.
CURR:MODE EXT	Sets main channel (current channel) to use an external level applied to the Analog I/O port.

To restore the above settings for power up, send \*SAV2. This saves the settings to memory location 2 (locations 1 through 15 can be used to establish initial power-up conditions). Set power-up switch S3 to 00010 to (S3-2 to 1) when performing a normal power-up (PAR. 3.3.2.2) to restore the saved settings from location 2 upon power up: Current mode, External limits enabled, limit to be the lesser of 10V (digital) or external limit signals applied to Analog I/O port.

### 3.4.3 MONITORING OUTPUT CURRENT USING AN ANALOG SIGNAL

The BOP provides output analog signals which are always available, 0 to  $\pm 10V$ , proportional to the output current and voltage. The current monitor signal is available at pin 3, referenced to pin 4, of the Analog I/O port. The voltage monitor signal is available at pin 15, referenced to pin 4, of the Analog I/O port.

## 3.5 DIGITAL CONTROL

### 3.5.1 PASSWORD PROTECTION

The Password is only effective when using digital control. The commands that can be password protected are SYST:SEC:IMM and all CALibration commands. When the unit is shipped, the password is set to DEFAULT. Refer to PAR B.141 to set a new password.

Before performing calibration or sending SYS:SEC:IMM, first send SYST:PASS:CEN (see PAR B.139). When calibration is complete or when SYST:SEC:IMM has been executed, it is recommended that the password state be disabled using SYST:PASS:CDIS (see PAR B.140).

### 3.5.2 SETTING OPERATING MODE (VOLTAGE OR CURRENT)

The BOP uses two separate channels, one to set output voltage or current and one to set the corresponding protection limit. When using digital control, the main channel is determined by the FUNC:MODE command which selects either Voltage mode or Current mode, or allows the status of Analog I/O port pin 2 to determine the mode (see PAR. 3.3.9 for details). The limit channel is determined automatically by the main channel selected. When Voltage mode is selected, the current protection limit channel is active, and when Current mode is selected, the Voltage protection limit channel is active.

### 3.5.3 PROGRAMMING VOLTAGE OR CURRENT AND ASSOCIATED PROTECT LIMITS

When the operating mode is Voltage mode, use the VOLT command (see PAR. B.88) where <exp\_value> = digits with decimal point and Exponent, e.g., 2.71E1 for 27.1. For example, send VOLT 2.71E1 to set output voltage to 27.1 Volts in voltage mode.

When the operating mode is Current mode use the CURR command (see PAR. B.88) where <exp\_value> = digits with decimal point and Exponent, e.g., 5.2-E1 for 0.52. For example, send CURR 5.2-E1 to set output current to 0.52A in current mode.

### **3.5.4 PROGRAMMING ASSOCIATED PROTECT LIMITS**

#### **3.5.4.1 WHEN OPERATING IN VOLTAGE MODE**

When the operating mode is Voltage mode, the following parameters are in effect (see Table 3-2 for definitions): +Voltage Max, –Voltage Min, +C Protect Max, +C Protect Min, –C Protect Max, –C Protect Min,  $\pm$ C Protect.

+Voltage Max and –Voltage Min are programmed using the VOLT:LIM commands (see PAR's. B.90 through B.95 for details). These commands limit the maximum  $\pm$ voltage that can appear at the output.

+C Protect Min and –C Protect Max cannot be programmed and are automatically set to minimum (box).

+C Protect Max and –C Protect Min. are programmed using the CURR:PROT:LIM commands (see PAR's. B.37 through B.42 for details.) These commands define the maximum values that  $\pm$ current protection ( $\pm$ C Protect) can be set to. If the programmed values are exceeded, a command error -201, "Current range error" occurs.

+C Protect and –C Protect are programmed using the CURR:PROT commands (see PAR's. B.29 through B.36 for details.) These commands program the  $\pm$ current protection values. If load current reaches the  $\pm$ current protection values, current will be clamped so  $\pm$ current protection values cannot be exceeded.

#### **3.5.4.2 WHEN OPERATING IN CURRENT MODE**

When the operating mode is Current mode, the following parameters are in effect (see Table 3-2 for definitions): +Current Max, –Current Min, +V Protect Max, +V Protect Min, –V Protect Max, –V Protect Min,  $\pm$ V Protect.

+Current Max and –Current Min are programmed using the CURR:LIM commands (see PAR's. B.90 through B.95 for details). These commands limit the maximum  $\pm$ current that can appear at the output.

+V Protect Min and –V Protect Max cannot be programmed and are automatically set to minimum (box).

+V Protect Max and –V Protect Min. are programmed using the VOLT:PROT:LIM commands (see PAR's. B.37 through B.42 for details.) These commands define the maximum values that  $\pm$ voltage protection ( $\pm$ V Protect) can be set to. If the programmed values are exceeded, a command error -201, "Voltage Range error" occurs.

+V Protect and –V Protect are programmed using the VOLT:PROT commands (see PAR's. B.29 through B.36 for details.) These commands program the  $\pm$ voltage protection values. If load voltage reaches the  $\pm$ voltage protection values, voltage will be clamped so  $\pm$ voltage protection values cannot be exceeded.

### 3.5.5 PROGRAMMING TECHNIQUES TO OPTIMIZE PERFORMANCE

#### 3.5.5.1 PROGRAMMING VOLTAGE/CURRENT LIMIT AND CURRENT/VOLTAGE LIMIT

Kepeco's auto-crossover digital supplies can operate in either voltage mode with current limit, or current mode with voltage limit. The operating mode is determined by the voltage and current commands received, as well as the load. Each time voltage and current commands are received, the unit will go to the corresponding mode (voltage or current) with either the main channel or the limit channel in control of the output (voltage or current), depending on the load value. Each time there is a potential mode change, there is always an uncontrolled period of a few fractions of milliseconds while the two feedback loops compete for control of the output. By changing only the active parameter (e.g., voltage for voltage mode), there is no doubt as to what the operating mode will be, so the unit is never uncontrolled, response is quick and no transients are possible. Recommended programming techniques are:

1. Minimize programmed mode (voltage or current) changes. Unless absolutely required by the test parameters, allow the power supply to automatically switch modes as determined by the load. This will improve response time and reduce undesirable transients.
2. Once the mode (voltage or current) is programmed, program the active parameter to zero and the complementary limit parameter to the maximum anticipated for application. Then program only the active parameter. The active parameter is the parameter that controls the output, e.g., voltage controls the output in voltage mode.
3. Never program both the active and complementary limit parameter to zero. This can result in long response times. Set the active parameter to zero and the complementary limit parameter to a minimum, e.g., 10% of maximum, to ensure that the active mode is defined.

#### 3.5.5.2 MAKING SURE THE PREVIOUS COMMAND IS COMPLETE

Some SCPI commands require a flash memory update and can take an indeterminate amount of time to complete. These commands are:

- \*SAV
- MEM:PACK (\*\*)
- MEM:UPD (\*\*)
- CAL:COPY
- CAL:SAVE
- SYST:PASS:NEW
- SYST:SEC:IMM (\*\*)
- SYST:SEC:OVER (\*\*)

**CAUTION:** The commands listed above with (\*\*) will generate a “-440, Missing Query” error if a query does not precede the command in the same command string or ;\*OPC? does not follow the command. Although commands not marked with (\*\*) will not generate an error, all commands listed above require verification to insure absolute success. **Failure to follow these rules can result in the loss of all stored constants and render the unit inoperative.**

When sending these commands via the GPIB, these commands require a query to be added to the command string to verify the previous command is complete. When the command is complete, the unit updates the status byte and indicates MAV (Message Available, bit 4 - see Table A-3) is true. MAV indicates that there is a response to be received by the computer, so when it becomes set, the unit is ready for its next command after reading back the data from the query that was added to the command string.

When sending the above commands via the RS 232 bus, data flow control must be enabled (XON) for the unit to properly update flash memory.

The \*OPC? query is ideal to check if the previous command is complete since it returns either a 1 or 0. It is important that it be sent as a part of the same string as the command that causes a flash update. As an example, sending CAL:SAVE 12/31/2005;:\*opc? or \*opc?;:CAL:SAVE 12/31/2005 are valid command strings. Sensing the commands separately will not verify that the previous command is complete. Figure 3-6 is a program written in C, incorporating these techniques.

Failure to provide an adequate delay can result in:

- Commands that are not processed,
- The following command may be received in error, causing an error in the transmission,
- Unit lock-up requiring power cycling of the unit. If working via the GPIB bus, sending Interface Clear and Device Clear followed by \*RST will unlock the unit.

### 3.5.6 STORING/RECALLING POWER SUPPLY OUTPUT SETTINGS

The power supply settings (mode, main channel reference type and setting, protection limit type and setting and output status) can be stored in one of 99 memory locations for later recall. This is accomplished using the \*SAV command (see PAR A.12).

To recall parameters previously saved in one of the 99 locations send \*RCL (see PAR A.10). Once the \*RCL command is issued, the stored settings are applied to the unit.

**CAUTION: If you are not sure what the saved settings are, disconnect the load before issuing \*RCL. Then issue queries to identify the stored settings.**

Locations 1 through 15 can be used to store settings for power-up. By setting the power-up switches (see PAR. 3.3.2.2) the settings previously saved to a location between 1 and 15 can be configured to be applied to the unit upon power-up. If this feature is to be used it is recommended that the unit be tagged with the location and saved settings to avoid unexpected behavior upon power-up.

```

#include <formatio.h>
#include <utility.h>
#include <gpib.h>
#include <ansi_c.h>

/*Overhead for the use of a NATIONAL INSTRUMENTS gpib interface */
int unit_desc; // handle for the national instruments controller
int GPIbus=0; // GPIB card 0
int adr=6; // Power Supply address
char status_byte; // status byte from the power supply

#define MAV 0x10 /* bit 4 of the status byte is the Message AVailable bit by 488.2 specification */

/* Function Send_with_wait

INPUT: string to be sent to power supply

Description: adds the *OPC? query and performs serial polls to wait for the command to be completed.

*/

int Send_with_wait(char *command);
char snd[501]; // data to be sent to the power supply
char rcv [10]; // data from power supply
int j;

sprintf(snd,"%s:*OPC?,command); // Add *OPC? to the command
// so there is a response from the
// power supply
Send(GPIbus, adr, snd, strlen(snd), 2); // Send the data to the power supply
for (j=0;j<500;j++){ // loop until ready (5 seconds max)
    Delay(.05); // Wait for command to complete
    ibrsp(unit_desc,&status_byte); // get status byte
    if ((status_byte& 0x10) ==0x10) break; // by looking for data in string
Receive (GPIbus, adr, rev, rev_buf_size,10); // so the error queue will not receive a 410 error
}

main( // test code to show operation of function.
    unit_desc=ibdev(GPIbus,adr,adr/256,T100ms,1,0x40a);Delay(.005);
    Send (GPIbus,adr,"VOLT 10;curr .01",sizeof("VOLT 10;curr .01"),NLEND;
    Send_with_wait("SAV 10");
}

```

**FIGURE 3-6. PROGRAMMING EXAMPLE TO VERIFY PREVIOUS COMMAND HAS COMPLETED**

### **3.5.7 WAVEFORM GENERATION**

#### **3.5.7.1 WAVEFORM OVERVIEW**

A waveform is comprised of at least one, or as many as 126 segments which are part of a series of LIST commands. Each segment has an individually specified value for Type, Frequency or Period, Amplitude, Offset, Start angle, Stop angle, and Initial/Repeat. These segments are programmed using the LIST:CURR:APPLY (PAR. B.57) or LIST:VOLT:APPLY (PAR. B.81) commands. The details of the waveform segments are defined in Table 3-6. Once the waveform segments are added to the list, the list is executed by sending either CURR:MODE LIST (PAR. B.27) or VOLT:MODE LIST (PAR. B.96).

### 3.5.7.2 UNDERSTANDING HOW WAVEFORMS ARE GENERATED

Waveform are generated by the BOP by producing a series of discrete output levels (points) in a prescribed pattern. In the case of sine, triangle and ramps, this produces an output that conforms to an approximation of the selected waveform type. The number of points available for a waveform is limited to 3933 for all segments. Since there are a finite number of points, the lower the frequency, the more points used, and the smoother the output waveform will appear. As the frequency increases, fewer points are available for each cycle and the resulting waveform may appear somewhat more jagged. Tables 3-4 and 3-5 list the number of points used for each frequency range of sine, triangle and ramp waveforms and for square waveforms, respectively. Levels use a maximum of 60 points.

This means that a waveform consisting of a single sinewave segment at 0.1 Hz will use all 3840 points to generate each cycle, while a sinewave at 440 Hz will use 24 points for each cycle. Note that a single segment between 0.01Hz and 1.8Hz uses all available points, so subsequent segments will result in an error "-223, "too much data" and some points may appear in the list. This can be corrected by either reducing the number of segments, or increasing the frequency of the existing segments until the point total is acceptable.

**TABLE 3-4. SINE, TRIANGLE AND RAMP WAVEFORM FREQUENCY VS. POINTS**

Frequency (See Notes 1, 2, and 3)		Total Points	Frequency (See Notes 1, 2, and 3)		Total Points
From	To		From	To	
0.01Hz	2.7Hz	3840	55.5Hz	66.5Hz	160
2.71Hz	3.6Hz	2880	66.6Hz	88.7Hz	120
3.71Hz	5.5Hz	1920	88.8Hz	118.3Hz	90
5.6Hz	8.3Hz	1280	118.4Hz	147.9Hz	72
8.4Hz	11.0Hz	960	148Hz	177.4Hz	60
11.1Hz	14.7Hz	720	177.5Hz	221.8Hz	48
14.8Hz	22.1Hz	480	221.9Hz	295.8Hz	36
22.2Hz	33.2Hz	320	295.81Hz	354.9Hz	30
33.3Hz	44.3Hz	240	355.9Hz	443.7Hz	24 (See Note 2)
44.4Hz	55.4Hz	192	443.8z	532Hz	20 (See Note 3)

NOTES: 1. As the frequency varies within the range, the time interval per point varies proportionately, decreasing as the frequency increases.  
 2. Sine and Triangle segments can not exceed 443Hz.  
 3. Ramp segments can not exceed 532Hz.

**TABLE 3-5. SQUARE WAVEFORM FREQUENCY VS. POINTS**

Frequency (See Note)		Total Points	Frequency (See Note)		Total Points
From	To		From	To	
0.02Hz	1.8Hz	3840	43.51Hz	58.0Hz	120
1.81Hz	2.7Hz	2880	58.01Hz	72.5Hz	90
2.71Hz	4.0Hz	1920	72.51Hz	87.0Hz	72
4.01	5.4Hz	1280	87.01Hz	108.7Hz	60
5.41	7.2Hz	960	108.71Hz	145.0Hz	48
7.21Hz	10.8Hz	720	145.2.9Hz	174.0Hz	36
10.81	16.3Hz	480	174.1Hz	217.5Hz	30
16.31Hz	21.7Hz	320	217.6Hz	261.0Hz	24
21.71Hz	27.1Hz	240	261.1Hz	435.0Hz	20
27.11Hz	32.6Hz	192	435Hz	652.5Hz	12
55.5Hz	66.5Hz	160	653	1000	10

NOTE: Time interval per point is inversely proportion to frequency variation within the range.

**3.5.7.3 WAVEFORM SPECIFICATIONS**

Refer to Table 1-2 for specifications applicable to waveforms created using LIST commands.

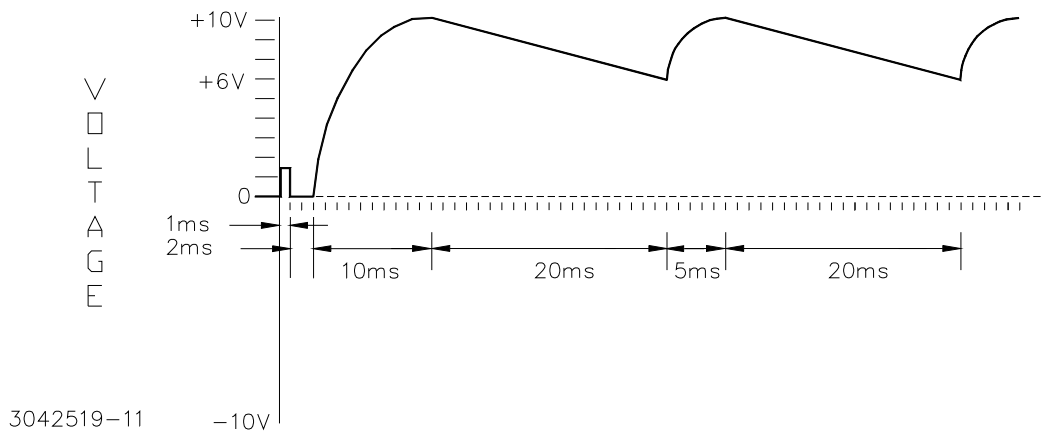

**FIGURE 3-7. SAMPLE WAVEFORM**

**3.5.7.4 EXECUTING A WAVEFORM**

These segments are programmed using the LIST:CURR:APPLY (PAR. B.57) or LIST:VOLT:APPLY (PAR. B.79) commands. The details of the waveform segments are defined in Table 3-6. Once the waveform segments are added to the list, the list is executed by sending either CURR:MODE LIST (PAR. B.27) or VOLT:MODE LIST (PAR. B.94).

It is recommended that an oscilloscope be used to view the output. **CAUTION: The oscilloscope must be floating before connecting to the OUT MON or OUT S terminals or the COM MON or COM S terminal of the BOP.** Connect the oscilloscope across OUT S and COM



S terminals of the rear panel terminal block to monitor the output at the load, or between OUT MON and COM MON to monitor the BOP output at the BOP (see Figure 2-1).

**TABLE 3-6. WAVEFORM SEGMENT DETAILS**

<b>SETTING</b>	<b>CHOICES</b>	<b>FUNCTION</b>
Type	Square Pos Ramp Neg Ram Triangle Sine Level	Square wave (constant 50% duty cycle), bipolar, starts with positive excursion (see Note). Pos Ramp - Increasing ramp, bipolar (see Note). Neg Ramp - Decreasing ramp, bipolar (see Note). Triangle - bipolar, starts with positive excursion, start/stop angle may be user controlled (see Note). Sine - bipolar, starts with positive excursion, start/stop angle may be user controlled (see Note). Level - value determined by offset., duration determined by Period.
Frequency (Hz) or Period (Sec) for Level only	xxxx.xxx (Hz) or xx.xxxx (Seconds)	Square wave: 0.02 to 1000 Hz Ramp: 0.02 to 532 Hz Sine or Triangle: 0.01 to 443 Hz Level: Period (duration) in seconds. 0.0005 to 5.0000 seconds
Amplitude (P to P)	xxx.xxx (Volts or Amperes)	Peak to peak amplitude of segment. Volts or Amperes determined by mode selected for waveform. Value within model rating acceptable (e.g., for BOP 100-10G, maximum amplitude is 200V). Values that exceed the maximum or minimum software limits (see PAR. 3.3.6) are neither accepted nor executed.
Offset	xxx.xxx (Volts or Amperes)	DC level on which the waveform (centered) will ride or Amplitude for Level segments. Volts or Amperes determined by mode selected for waveform. E.g. for BOP 100-10G, to specify a positive ramp that goes from +30V to +80V, set amplitude to +50V and offset to +55V. Since p-p amplitude of segment is centered on offset, it is possible for the waveform to exceed the model ratings (e.g., for the BOP 100-10G, if the amplitude is set to 150V and the offset is -50V, the negative portion of the segment will exceed the -100V maximum of the model). In this case the output is clamped to the max/min software limit in effect (see PAR. 3.3.5.1). Values that exceed the maximum or minimum software limits (see PAR. 3.3.6) are neither accepted nor executed.
Start Angle (Sine or Triangle only)	xxx x (degrees)	The point at which the sine or triangle waveform segment starts. Values from 0.0° to 360.0° are acceptable. Default is 0.0°.
Stop Angle (Sine or Triangle only)	xxx x (degrees)	The point at which the sine or triangle waveform segment stops. Values from 0.0° to 360.0° acceptable. Default is 0.0° (functions the same as 360°).
Initial/ Repeat	Repeating Initial	Repeating - Segment is executed for each cycle specified by the Count. Initial - Segment is executed only on the first count and skipped for all subsequent counts. Useful for preconditioning applications or establishing an initial delay. All segments except the last may be set to Initial or Repeating. The last segment is always Repeating
<p>NOTE: All waveforms except Level are centered on the offset. E.g. for a BOP 100-10G, a positive ramp of 100V p-p amplitude, 10V offset, will start at -40V and increase to +60V over the time period (T) determined by the frequency (F): T = 1/F.</p>		

**3.5.7.5 USING SEGMENTS TO BUILD A WAVEFORM**

The following steps provide detailed instructions to show how a complex waveform, illustrated in Figure 3-7, may be created by building segments. Refer to PAR. 3.7.3.3 additional information of the use of LIST commands.

- 1. Send the following commands to create the trigger pulse and leading 0 volt level of the sample waveform (see Figure 3-7).  

LIST:CLE                                      Clears the list. Lists are not automatically deleted, but cannot be saved for power-up.

LIST:VOLT:APPL LEV,.001,1.5      Sets the first segment at 1.5 volts for 1 millisecond.

LIST:VOLT:APPL LEV,.002,0      Sets the zero segment for 2 milliseconds.

2. Send the following commands to create another segment which is the first quadrant of a 20V p-p sine wave riding on a 0V offset. It starts at 0V and rises to 10V (1/2 of 20) over 10 ms (1/4 of 40ms period established by 25Hz frequency). This segment simulates the initial charging of a capacitor.

LIST:VOLT:APPL:SWE 0,90      Prepares for the initial charge waveform.

LIST:VOLT:APPL SINE,25,20,0 Creates the initial curve of the charge constant.

3. Send the following commands to determine how many points are in the initial waveform segments and set this value to flag the initial (non-repeating) segments of the waveform.

LIST:DWEL:POIN?              Returns xxxx that represents the initial non repeating points.

LIST:COUN:SKIP xxxx          Use the value from previous command to establish skip point.

4. Send the following commands to create a repeating negative ramp starting at +10V decreasing to +6V since it is a 4V p-p signal riding on an 8V offset. The frequency of 50 Hz establishes the time duration of 20 mS for the segment.

LIST:VOLT:APPL:SWE 0,360      Sets up the unit to accept all points in waveform.

LIST:VOLT:APPL RAMP 50,5,8    50Hz, 5V p-p, 8V offset

5. Send the following commands to create a repeating 1/4 sine wave that starts at 6V and rises to 10V over 5 ms (1/4 of 20ms period established by 50Hz frequency). The waveform shown in Figure 3-7 has now been created. Note that by careful calculation of period and start/stop angle, accurate waveform simulations can be attained.

LIST:VOLT:APPL:SWE 0,90      Prepares for the initial charge waveform.

LIST:VOLT:APPL SINE,50,8,6    Creates the repeating curve of the charge constant.

6. Send the following commands to execute the waveform.

CURR:PROT 10                  Establishes how much current will be supplied by the unit.

LIST:COUNT 0                  Causes the waveform to continue indefinitely.

VOLT:MODE LIST                  Starts the waveform.

7. To stop the waveform immediately (at its current point) send VOLT:MODE FIX.
8. To stop the waveform at the end of the cycle (12 volts) send VOLT:MODE HALT.

### 3.5.8 RESET

The \*RST command resets the unit (See PAR. A.11). Table 3-7 describes how the unit operates depending on how **\*RST set Output** is configured, and the load type selected. The user can control whether the \*RST command sets the output on or off. The \*RST command can be configured using the SYST:SET command (PAR. B.146).

**TABLE 3-7. OPERATION OF #RST COMMAND**

Load type when *RST Issued (see NOTE)	BOP Status After *RST Issued
<ul style="list-style-type: none"> <li>• Active or Resistive Load (see PAR. 3.5.5)</li> </ul>	<ul style="list-style-type: none"> <li>• Voltage mode</li> <li>• Main Channel reference set to 0.0V</li> <li>• Current protect set to 5% of <math>I_{Onom}</math></li> <li>• Voltage protect set to 5% above <math>E_{Onom}</math></li> </ul>
<ul style="list-style-type: none"> <li>• Battery Load (see PAR. 3.5.5)</li> </ul>	<ul style="list-style-type: none"> <li>• If *RST set to ON, unit is set to Voltage Mode</li> <li>• If *RST set to OFF unit is set to Current Mode</li> <li>• Main Channel reference set to 0.0A</li> <li>• Current protect set to 5% of <math>I_{Onom}</math></li> <li>• Voltage protect set to 5% above <math>E_{Onom}</math></li> </ul>
NOTE: Prior to issuing *RST unit may be operating in either voltage mode or current mode.	

### 3.5.9 ERROR MESSAGE EXPLANATIONS

Refer to Table B-5 for an explanation of error messages returned by the SYST:ERR? (PAR. B.134) query.

### 3.6 PROGRAMMING USING DIGITAL CONTROL

BOP models may be digitally programmed over a control bus using SCPI (Standard Commands for Programmable Instruments). SCPI provides a common language conforming to IEEE 488.2 for instruments used in an automatic test system (see PAR. 3.7). The control bus used must be either the IEEE 488 standard communication bus (General Purpose Interface Bus, GPIB), or the RS 232C Serial Bus.

Refer to Table 2-12 for input/output signal allocations for communication via the GPIB, Table 2-6 for RS 232, and Table 2-3 for the BITBUS.

This section includes a discussion of GPIB bus protocols (PAR. 3.6.3), instructions for changing the GPIB address (PAR. 3.6.3.1.1), RS 232C Operation (PAR. 3.6.4), a discussion of the VISA (Virtual Instrumentation Software Architecture) driver supplied with the unit (PAR. 3.6.5), followed by a detailed explanation of SCPI programming (PAR. 3.7).

When either of the two interface ports are in use, PAR's 3.6.3.1 (GPIB) and 3.6.4.3 (RS 232) describe how to configure the port to meet the user's requirements.

The BOP can be conveniently substituted for a standard BOP that is currently being used with one of Kepco's BIT cards by using one of the Compatibility Modes provided (see PAR. 3.6.1 and 3.6.2).

The `SYSTEM:SET` (PAR. B.146) command can be used to configure the BOP to operate in a manner consistent with earlier models of Kepco's 100W, 200W and 400W BOP power supplies.

### 3.6.1 BIT 4882 COMPATIBILITY.

To replace a standard low power BOP/BIT 4882 card combination with a 1KW BOP-G with minimal reconfiguration of existing test setups, send `SYSTEM:SET 4882` followed by `MEMORY:UPDATE INTERFACE`.

### 3.6.2 BIT 4886 COMPATIBILITY

To replace a standard low power BOP/BIT 4886 card combination with a 1KW BOP-G with minimal reconfiguration of existing test setups, send `SYSTEM:SET 4886`.

### 3.6.3 IEEE 488 (GPIB) BUS PROTOCOL

Table 3-8 defines the interface capabilities of the BOP power supply (Talker/Listener) relative to the IEEE 488 (GPIB) bus (reference document *ANSI/IEEE Std 488: IEEE Standard Digital Interface for Programmable Instrumentation*) communicating with a Host Computer—Controller (Talker/Listener). Tables 3-9 and 3-10 define the messages sent by the BOP, or received by the BOP, via the IEEE 488 bus in IEEE 488 command mode and IEEE 488 data mode, respectively. These messages are enabled during the “handshake” cycle, with the BOP power supply operating as either a Talker or a Listener. (See PAR. 3.6.3.1 to change the GPIB address.)

**CAUTION:** To ensure correct operation, do not remove the GPIB cable from the BOP after a Query is processed. Ensure that the last command is a non-query such as `*CLS` before removing the GPIB cable. Otherwise, power to the BOP and/or the host computer may need to be cycled OFF then ON to restore proper operation.

**TABLE 3-8. IEEE 488 (GPIB) BUS INTERFACE FUNCTIONS**

FUNCTION	SUBSET SYMBOL	COMMENTS
Source Handshake	SH1	Complete Capability (Interface can receive multiline messages)
Acceptor Handshake	AH1	Complete Capability (Interface can receive multiline messages)
Talker	T6	Basic talker, serial poll, unaddress if MLA (My Listen Address) (one-byte address)
Listener	L4	Basic listener, unaddress if MTA (My Talk Address) (one-byte address).
Service Request	SR1	Complete Capability. The interface sets the SRQ line true if there is an enabled service request condition.
Remote/Local	RL1	Complete capability. Interface selects either local or remote information. In local mode the BOP enables the analog programming inputs. The unit automatically enters remote mode (digital control) when the first SCPI command is received.
Parallel Poll	PP0	No Capability
Device Clear	DC1	Complete Capability. BOP accepts DCL (Device Clear) and SDC (Selected Device Clear).
Device Trigger	DT1	Respond to <code>*TRG</code> and <code>&lt;GET&gt;</code> trigger functions.
Controller	C0	No Capability

**TABLE 3-9. IEEE 488 (GPIB) BUS COMMAND MODE MESSAGES**

MNEMONIC	MESSAGE DESCRIPTION	COMMENTS
ATN	Attention	Received
DAC	Data accepted	Received or Sent
DAV	Data Valid	Received or Sent
DCL	Device Clear	Received (see PAR. 3.6.3.1.2)
IFC	Interface Clear	Received
MLA	My Listen Address	Received
MTA	My Talk Address	Received
OTA	Other Talk Address	Received
RFD	Ready for Data	Received or Sent
SDC	Selected Device Clear	Received
SPD	Serial Poll Disable	Received
SPE	Serial Poll Enable	Received
SRQ	Service Request	Sent
UNL	Unlisten	Received
UNT	Untalk	Received

**TABLE 3-10. IEEE 488 (GPIB) BUS DATA MODE MESSAGES**

MNEMONIC	MESSAGE DESCRIPTION	COMMENTS
DAB	Data Byte	Received or Sent
END	End	Received or Sent
EOS	End of String	Received or Sent
RQS	Request Service	Sent
STB	Status Byte	Sent

**3.6.3.1 GPIB PORT SETUP**

The following paragraphs describe the how to configure the GPIB port.

**3.6.3.1.1 CHANGING THE GPIB ADDRESS**

The default address is 6. To change the GPIB address use the SYST:COMM:GPIB:ADDR command (PAR B.124). To configure a particular GPIB address to implemented upon power-up, refer to PAR. 3.3.2.2).

### 3.6.3.1.2 CONFIGURE DEVICE CLEAR (DCL) CONTROL

The device clear (DCL) and selected device clear can be set to operate in two modes. In the MATE mode (DCL1), when the device clear is received, the output of the power supply is set to zero volts. In the SCPI mode (DCL0) sending DCL or selected DCL has no effect on output voltage and current as required by IEEE specification 488.2. The factory default value is SCPI mode (DCL0) (see PAR. B.146).

### 3.6.3.1.3 DETERMINING WHETHER \*RST COMMAND SETS THE OUTPUT OFF OR ON

Refer to PAR. B.146 (RO0 or RO1) to configure how the unit responds to the \*RST (reset) command. See PAR. 3.5.8 to understand how the unit behaves when output is off (disabled) or on (enabled) with different load types.

## 3.6.4 RS232-C OPERATION

The BOP may be operated via an RS232-C terminal, or from a PC using a terminal emulation program. The default settings are as follows:

- Baud rate: OFF
- Parity: None
- Data Bits 8
- Stop Bits 1
- Prompt DISABLE
- XON/XOFF ENABLE

To configure baud rate, prompt, echo or XON/XOFF, refer to PAR. 3.6.4.3. Behavior of the serial interface is described in PAR. 3.6.4.1 and RS 232 Implementation is described in PAR. 3.6.4.2.

### 3.6.4.1 SERIAL INTERFACE

The serial interface behaves like the GPIB interface in that the command is parsed after receiving a control character of either a Line Feed or Carriage Return. The serial interface supports six special control characters. The six special control characters are:

- |                                    |  |
|------------------------------------|--|
| Escape (1B <sub>H</sub> )          | Causes the input buffer to be cleared. This character is used to ensure that the buffer is empty when the host powers on since it is possible that the unit was previously powered on and received some characters prior to the initialization of the host computer. |
| Backspace (08 <sub>H</sub> )       | Causes the last character in the input buffer to be removed from the input buffer queue.   |
| Carriage Return (0D <sub>H</sub> ) | Causes the input buffer to be parsed by the BOP.   |
| Line Feed (0A <sub>H</sub> )       | Causes the input buffer to be parsed by the BOP.   |

### 3.6.4.2 RS 232 IMPLEMENTATION

The following paragraphs are provided to help the user understand how the RS 232 serial interface is implemented in the BOP. Since the RS 232 protocol does not use a parity bit, the

XON/XOFF method of communication is selected as the default to ensure “handshake” control of serial communication.

The echo mode is an optional method used to ensure reliable communication between the command originator (computer) and the BOP power supply, thus avoiding a more complex “handshake” protocol. When the BOP is in the RS 232 echo mode it returns all data sent to the host controller.

The BOP provides an additional option that allow handshake communication: the Prompt method. By using the handshake options (prompt and XON XOFF) the host controller can ensure that serial data interrupts occurring after parsing of the incoming message do not result in lost data.

Figure 3-8 illustrates the echo mode, the prompt method and the default XON XOFF method described in the following paragraphs.

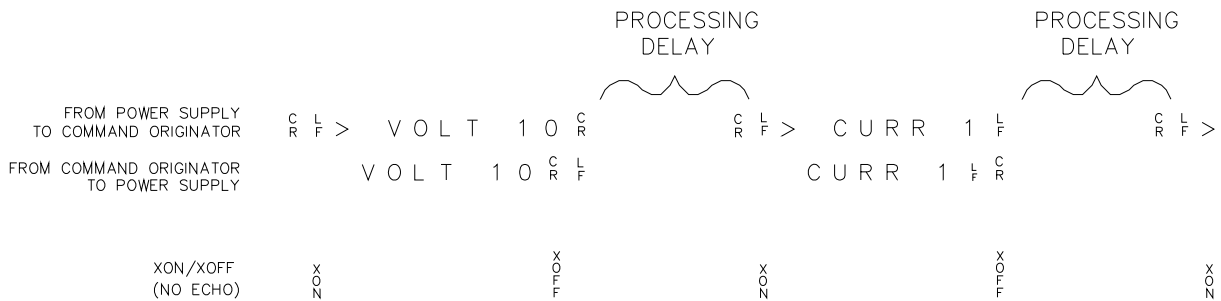

3042536

**FIGURE 3-8. RS 232 IMPLEMENTATION**

Only seven control characters (characters between 00<sub>H</sub> and 1F<sub>H</sub>) are acknowledged by the power supply:

- Carriage Return (CR, 0D<sub>H</sub>)
- Line Feed (LF, 0A<sub>H</sub>)
- Back Space (BS, 08<sub>H</sub>)
- Escape (ESC, 01B<sub>H</sub>)
- XON (011<sub>H</sub>)
- XOFF (013<sub>H</sub>)
- CAN (018<sub>H</sub>)

BS deletes the last character entered, with the exception of CR or LF characters. Either the CR or LF character acts as the line terminator, initiating parsing of the ASCII data sent to the BOP by the command originator. When the line is parsed and the commands are sent to the analog processor, the BOP sends the line terminator sequence CR LF to the command originator.

The ESC character is used for synchronization, causing the BOP to reset its input buffer and return a CR LF sequence.

The XON character enables the transmitter if XON/XOFF flow control is enabled (see PAR. 3.6.4.3.3).

The XOFF character stops data transmission if XON/XOFF flow control is enabled (see PAR. 3.6.4.3.3).

The CAN character resets the receive and transmit pointers and queues.

**CAUTION:** When the serial port has received an XOFF, the error message *-400, "Query Error"* will be placed in the queue to indicate the loss of transmitted information due to a received XOFF character. When XON is received, the unit will transmit all data in its buffer followed by the exclamation character (!). This (!) character is not part of any message from the BOP and indicates the transmission buffer has been cleared and the BOP is idle.

All non-control characters are sent via the serial port of the command originator. The control character BS is echoed as BS Space BS. Only the first control character is returned in response to either a CR LF or LF CR character sequence (see Figure 3-8).

#### 3.6.4.2.1 XON XOFF METHOD

The XON XOFF method allows the BOP to control when the command originator is allowed to send data. The command originator can only send data after the XON (transmission on) character (011<sub>H</sub>) has been received; the command originator stops sending data after receiving the XOFF (transmission off) character (013<sub>H</sub>), and waits until the XON character is received before sending additional data.

Control characters, either CR or LF, are returned as XOFF CR if echo mode is on, and as XOFF if echo mode is off. XOFF stops data from the command originator and the BOP returns the normal sequence of CR LF (if echo mode is enabled).

#### 3.6.4.2.2 ECHO MODE

Echo mode is one method of ensuring data is transferred without errors. This mode should only be enabled when errors in operation are detected.

Each byte (character) is echoed back to the sender where it is verified as the same character that was just sent. If the wrong character is echoed back, sending the ESC character clears the line to allow retransmission of the character. It is important the CR and LF characters are NOT sent until the verification process is complete.

When working in echo mode, it is possible to receive the NAK (15 hex) from the BOP. This indicates an unknown quantity of echoed characters have been lost due to a queue overflow problem. The error queue will also contain the *-400, QUE error* message. To prevent this, please insure the received data string does not exceed 127 characters between line terminators and no more than four queries are sent between line terminators in SCPI mode of operation.

All non-control characters are sent via the serial port of the command originator.



### 3.6.4.2.3 PROMPT METHOD

The command originator sends a message line (command) to the BOP and waits until the prompt sequence CR LF > (3E<sub>H</sub>, 62<sub>10</sub>) is received. The BOP sends the prompt sequence CR LF > to the command originator indicating the power supply is ready to receive the next command and data will not be lost. This method is useful in an interactive mode as well as with certain process controllers.

### 3.6.4.3 RS 232 SERIAL PORT SETUP

The unit must be in remote mode before the RS 232 commands to affect the output can be executed (e.g., VOLT 10;OUTP ON). This can be accomplished by sending SYST:REM ON prior to sending any commands that affect the power supply output. (See PAR. B.143 and Figure B-12). Verify that the DIG. CTRL LED on the front panel is lit.

Paragraphs 3.6.4.3.1 through 3.6.4.3.4 below describe the commands required for the BOP to communicate via the RS 232C Serial bus using SCPI commands. NOTE: If the default.

NOTE: To save RS 232 configuration changes for subsequent power-up cycles, send MEM:UPD:SER and tag unit with new revised power-up setting(s).

#### 3.6.4.3.1 SELECT BAUD RATE

The default baud rate is 9600, established by power-up switch S3-1 set to 0 during Reset Power-up. To establish a baud rate of 19.2K upon power-up, set power-up switch S3-1 to 1 and perform the Reset Power-up (see PAR. 3.3.2.1). The baud rate can also be changed using the command SYST:COMM:SER:BAUD (see PAR. B.126). To save changes for subsequent power-up cycles, send MEM:UPD:SER and tag unit with new power-up setting.

NOTE: If changes to the RS 232 configuration must be implemented using the RS 232 port rather than the GPIB port, it is recommended to send the commands at no more than one command every 10 seconds.

#### 3.6.4.3.2 CONFIGURE ECHO PROTOCOL

The ECHO protocol can be enabled/disabled using the SYST:COMM:SER:ECHO command (see PAR. B.128). See PAR. 3.6.4.2.2 for a description of echo mode. The \*RST command has no effect on echo status. See PAR. 3.5.5.2 and Figure 3-6 for special programming considerations.

**Enable** - Causes all subsequent characters to be echoed back.

**Disable** - Turns off the character echo after the next line terminator character.

#### 3.6.4.3.3 CONFIGURE XON/XOFF PROTOCOL

The XON/XOFF protocol can be enabled/disabled using the SYST:COMM:SER:PACE command (see PAR. B.130).

**Enable** - Allows BOP to control when data is received (see PAR. 3.6.4.2.1 for a description of Xon/Xoff protocol).

**Disable** - Disables XON/XOFF. If both Serial XON/XOFF and Prompt functions are disabled, Echo mode is set (see PAR. 3.6.4.2.2 for a description of echo mode).

#### 3.6.4.3.4 CONFIGURE PROMPT MODE

The prompt mode can be controlled using the SYST:COMM:SER:PROM command (see PAR. B.132). (See PAR. 3.6.4.2.3 for a description of prompt mode). To save changes for subsequent power-up cycles, send MEM:UPD:SER and tag unit with new revised power-up setting.

**Enable** - Enables Serial Prompt (see PAR. 3.6.4.2.3 for a description of prompt mode).

**Disable** - Disables Prompt. If both Serial XON/XOFF and Prompt functions are disabled, Echo mode is the default (see PAR. 3.6.4.2.2 for a description of Xon/Xoff mode).

If both Serial Prompt (see PAR. 3.6.4.2.3) and Echo (see PAR. 3.6.4.2.2) modes. are enabled, Prompt is returned when the unit is ready and any received characters are echoed back to the sender.

#### 3.6.5 BOP VISA INSTRUMENT DRIVER

The VISA instrument driver for the BOP power supply, available for download at [www.kepcopower.com/drivers.htm](http://www.kepcopower.com/drivers.htm), simplifies programming with a VISA compatible GPIB controller. Included are:

- source code (C) for all VISA functions (kp\_bophi.c)
- a complete programming reference manual (kp\_bophi.doc)
- a sample application of the VISA functions (written in C) which can be used to program one or more BOP power supplies using a virtual front panel observed on a computer monitor (kp\_appl.c)

Although the software drivers supplied by Kepco are VISA compliant, they also require the installation of the proper VISA driver from your GPIB card supplier. Many vendors supply this software with the hardware; National Instruments (<http://www.natinst.com>) has the driver for their cards available on the internet at a file transfer site (<ftp://ftp.natinst.com> — find the folder for support and VISA drivers).

### 3.7 SCPI PROGRAMMING

SCPI (Standard Commands for Programmable Instruments) is a programming language conforming to the protocols and standards established by IEEE 488.2 (reference document *ANSI/IEEE Std 488.2, IEEE Standard Codes, Formats, Protocols, and Common Commands*). SCPI commands are sent to the BOP Power Supply as ASCII output strings within the selected programming language (PASCAL, BASIC, etc.) in accordance with the manufacturer's requirements for the particular GPIB controller card used.

Different programming languages (e.g., BASIC, C, PASCAL, etc.) have different ways of representing data that is to be put on the IEEE 488 bus. It is up to the programmer to determine how to output the character sequence required for the programming language used. Address information (GPIB address) must be included before the command sequence. (See PAR.3.6.3.1.1 to establish the BOP Power Supply GPIB address.)

### **3.7.1 SCPI MESSAGES**

There are two kinds of SCPI messages: program messages from controller to power supply, and response messages from the power supply to the controller. Program messages consist of one or more properly formatted commands/queries and instruct the power supply to perform an action; the controller may send a program message at any time. Response messages consist of formatted data; the data can contain information regarding operating parameters, power supply state, status, or error conditions.

### **3.7.2 COMMON COMMANDS/QUERIES**

Common commands and queries are defined by the IEEE 488.2 standard to perform overall power supply functions (such as identification, status, or synchronization) unrelated to specific power supply operation (such as setting voltage/current). Common commands and queries are preceded by an asterisk (\*) and are defined and explained in Appendix A (see Table 4-4). Refer also to syntax considerations (PARs 3.4.3 through 3.4.6).

### **3.7.3 SCPI SUBSYSTEM COMMAND/QUERY STRUCTURE**

Subsystem commands/queries are related to specific power supply functions (such as setting output voltage, current limit, etc.) Figure 3-9 is a tree diagram illustrating the structure of SCPI subsystem commands used in the BOP Power Supply with the "root" at the left side, and specific commands forming the branches. The following paragraphs introduce the subsystems; subsystem commands are defined and explained in Appendix B.

#### **3.7.3.1 ABORT SUBSYSTEM**

This subsystem allows pending trigger levels to be cancelled.

#### **3.7.3.2 INITIATE SUBSYSTEM**

This subsystem enables the trigger system. When a trigger is enabled, the triggering action will occur upon receipt of a GPIB <GET>, \*TRG or TRIGger command. If a trigger circuit is not enabled, all trigger commands are ignored.

#### **3.7.3.3 LIST SUBSYSTEM**

The LIST subsystem is used to generate transients, waveforms and execute a series of steps (points) repeatedly. Up to 1002 power supply settings can be stored temporarily. Each setting consists of either a voltage or current value (depending on whether the power supply has been set to Voltage or Current mode), and a corresponding dwell time (the duration those settings are in effect). These settings may be executed in sequence as they are entered, or executed in a user-determined sequence that also allows individual settings to be repeated more than once. In addition, the entire sequence may be repeated for a specific number of times, or run indefinitely until commanded to stop. The sequence can also be run in reverse order to produce inverted waveforms.

Each point contains a value for the main channel (either voltage or current) and the duration (dwell) that the value will appear at the output (from 93 microseconds to 0.034 second. The list system supports from 2950 to 5900 points per waveform, depending on the number of different dwells in the waveform: For example, if each point in the list has the same duration (a single dwell time), 5900 points are supported; if no more than 126 different dwell times are specified, 3933 points are supported, and if each point has a different dwell, a maximum of 2950 points are supported. The number of points supported is determined automatically by the BOP firmware.

The LIST subsystem includes a subsystem for waveform generation. The waveform generation is invoked with the verb APPLY. When APPLY is added to a list:volt or list:curr command, the BOP adds a series of points to the list arrays. The BOP can apply these points to approximate a SINE, Triangle, RAMP (positive or negative) or square waveform or a level. The basic command requires a type, frequency (or period for a level), a peak-to-peak amplitude (or amplitude for a level), and offset (offset not needed for a level) The unit will create an appropriate number of points in both the dwell and output control array to create the waveform centered on zero volts. An optional offset can be added to the command to cause the BOP to generate a non-centered waveform. For example, a 5 volt 400 Hertz sine wave may be centered at -3 volts. The list subsystem allows the user to modify the unit's behavior to generate parts of waveforms and to used specific dwell times as appropriate. The APPLY subsystem accommodates 126 different segments in a single waveform provided the generated points fit in the array. See paragraph 3.5.7.2 for an explanation of how a waveform is generated by the BOP.

The following paragraphs provide guidance for using the list commands.

### **3.7.3.3.1 REQUIRED LIST COMMANDS**

There are only five LIST commands, plus either the VOLT:MODE (PAR. B.96) or CURR:MODE (PAR. B.27) command, that are needed to create and execute a list. Use of these required commands is illustrated in Figure B-6 which shows the creation of sawtooth and triangular waveforms. LIST commands are not accepted while a list is running. Send VOLT:MODE FIX (PAR. B.96) or CURR:MODE FIX (PAR. B.27) to stop the list. A list remains in memory until the power is cycled or the LIST:CLEAr (PAR. B.49) command is processed. Therefore, if the original list is unchanged, additional commands can be added to the end of the list without resending all the commands. However, to change parameters of one or more commands within the list, send LIST:CLEAR and then resend the entire list including the changed parameters. To execute the list again, either VOLT:MODE LIST (PAR. B.96) or CURR:MODE LIST (PAR. B.27) must be sent again.

LIST:VOLT (PAR. B.79) or LIST:CURR (PAR. B.54). These commands establish the points (steps) of a list which program output voltage or current. A list can only be either a voltage list or a current list, so the points in a list must be made with either LIST:VOLT XXXX or LIST:CURR XXXX. Mixing of these commands within a list is not allowed.

LIST:CLEAR (PAR. B.49). Always precede a new list with this command. A list remains in memory until the power is cycled or the LIST:CLEAR command is processed.

LIST:DWELL (PAR. B.62). Defines the dwell time for each point in a list. In many instances it is easier to use one dwell time and repeat a specific point multiple times to generate longer duration pulses. Remember, if more than one LIST:DWELL is sent, there must be a LIST:DWELL for each voltage or current point in the list.

LIST:COUNT (PAR. ) Defines how many times a list is executed. 0 equals indefinite; when a count of 0 is used, either \*RST, VOLT:MODE FIX or CURR:MODE FIX must be used to stop the list. \*RST will cause the output to be set off and the unit is set to Voltage mode. VOLT:MODE FIX or CURR:MODE FIX stops the list immediately; the point being executed when the list is stopped will be present at the BOP output.

### **3.7.3.3.2 OTHER REQUIRED COMMANDS**

VOLT:MODE LIST (PAR. B.96) or CURR:MODE LIST (PAR. B.27). These commands start the list and VOLT:MODE FIX (PAR. B.96) or CURR:MODE FIX (PAR. B.27) stop the list. LIST commands are not accepted while a list is running. If LIST:COUNT is between 1 and 255, when the count decrements to 0, the list stops and the unit automatically moves to VOLT:MODE FIXED or CURR:MODE FIXED state. To execute the list again, either VOLT:MODE LIST or CURR:MODE LIST must be sent again.

### **3.7.3.3.3 OTHER USEFUL COMMANDS**

LIST:COUNT:Skip (PAR. B.53). This command provides the ability to execute the initial points only once whenever a list is run. It is used to set initial preconditions prior to running a repetitive sequence.

LIST:VOLT:POINTS? (PAR. B.81) or LIST:CURR:POINTS? (PAR. B.59) These queries return the number of points in a list and provide a simple way to insure that all points entered were properly processed and as intended.

### **3.7.3.3.4 OPTIONAL COMMANDS**

Most commands have associated Queries (?) These are useful for troubleshooting/debugging lists but are not needed in most cases.

### **3.7.3.4 MEASURE SUBSYSTEM**

This query subsystem returns the voltage and current measured at the power supply's output terminals.

### **3.7.3.5 OUTPUT SUBSYSTEM**

This subsystem controls whether the power supply output is disabled or enabled.

### 3.7.3.6 MEMORY SUBSYSTEM

This subsystem controls the Flash Memory used by the BOP microprocessors and is used for storing setup parameters and for storing a list for later recall and execution

The unit's configuration, voltage and current, saved setups (\*SAV and \*RCL command) and Calibration values are stored in Flash Memory. Since the Flash EEPROM cannot be modified by writing a single data byte, the block must be erased and then the data written into the correct locations.

Saved setups are accomplished by the 99 memory locations (groups of settings) which are stored in the nonvolatile memory. Each setting contains values for: Mode, main channel setting (voltage or current), Reference setting, positive and negative protect values and External Protect setting (see Table 3-8).

The BOP accomplishes this by partitioning the Flash memory. As the amount of Flash memory used becomes larger with each subsequent data update, the Flash memory fills up and needs to be compressed. The compression of the Flash EEPROM, called packing, is automatically handled by the BOP microprocessor's code. The packing process can take a half a second to accomplish. Because it is automatically executed, it can occur after any \*SAV or save of Calibration. When the memory is out of space, the internal microprocessor moves the any data in the first page to the end of the flash array and then erases the first flash page. The pack process can take 500 milliseconds to complete. Packing is automatically invoked during power-up initialization if the BOP finds that any storage area is over 90% utilized.

The following statistics are a guide as to when a MEMORY PACK will occur.

- Save area - Approximately 300 \*SAV operations can be completed before a PACK will occur automatically.
- Variable area - around 3000 updates can be completed prior to an automatic PACK occurring. Variable areas also include serial number updates and password updates.
- Calibration - 64 calibrations can be saved before a PACK is required.

ROOT : (colon)

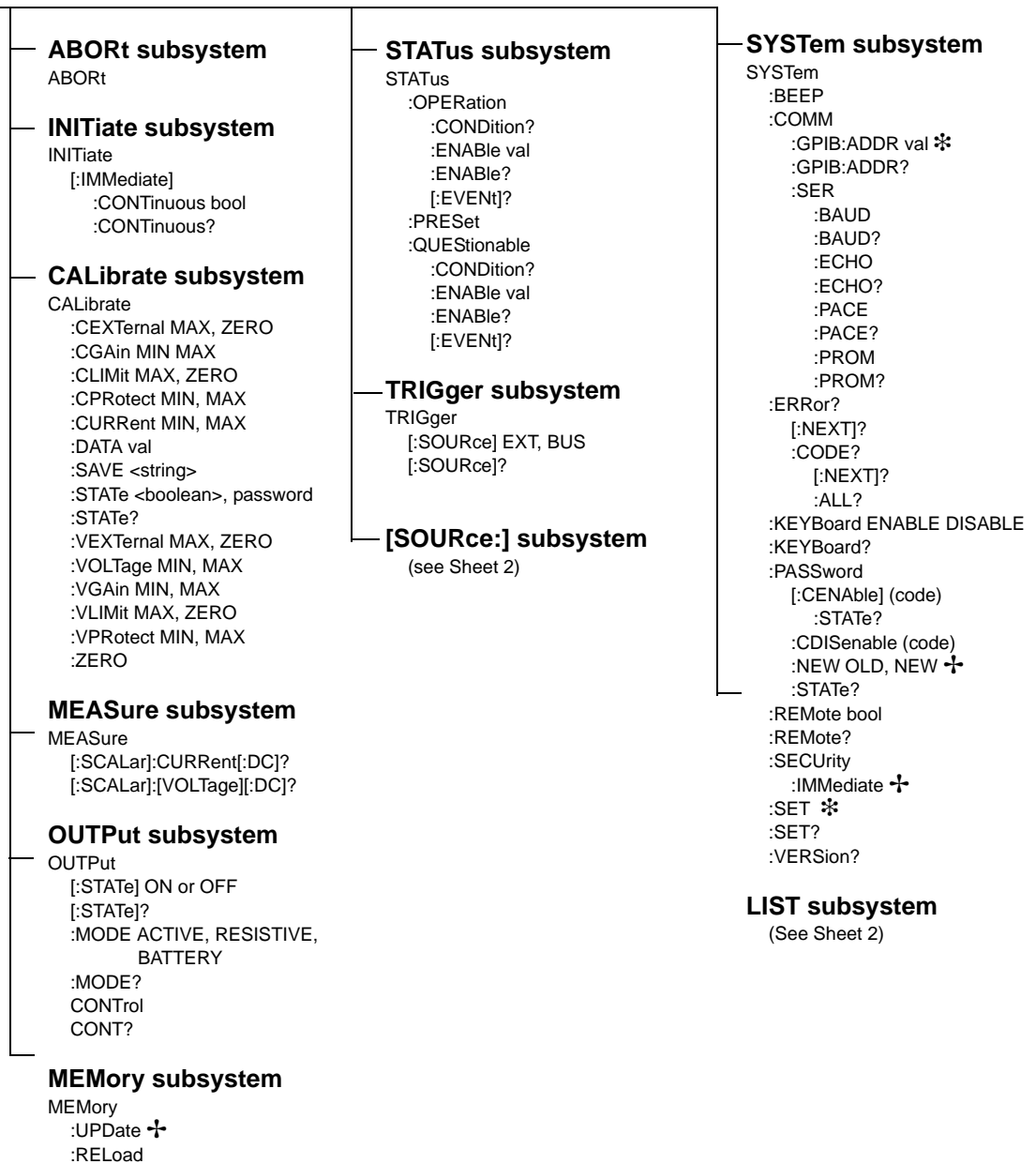

† See PAR. 3.5.5.2 and Figure 3-6 for special programming considerations.

\* Requires MEM:UPD to save for power-up.

FIGURE 3-9. TREE DIAGRAM OF SCPI COMMANDS USED WITH BOP POWER SUPPLY (SHEET 1 OF 2)

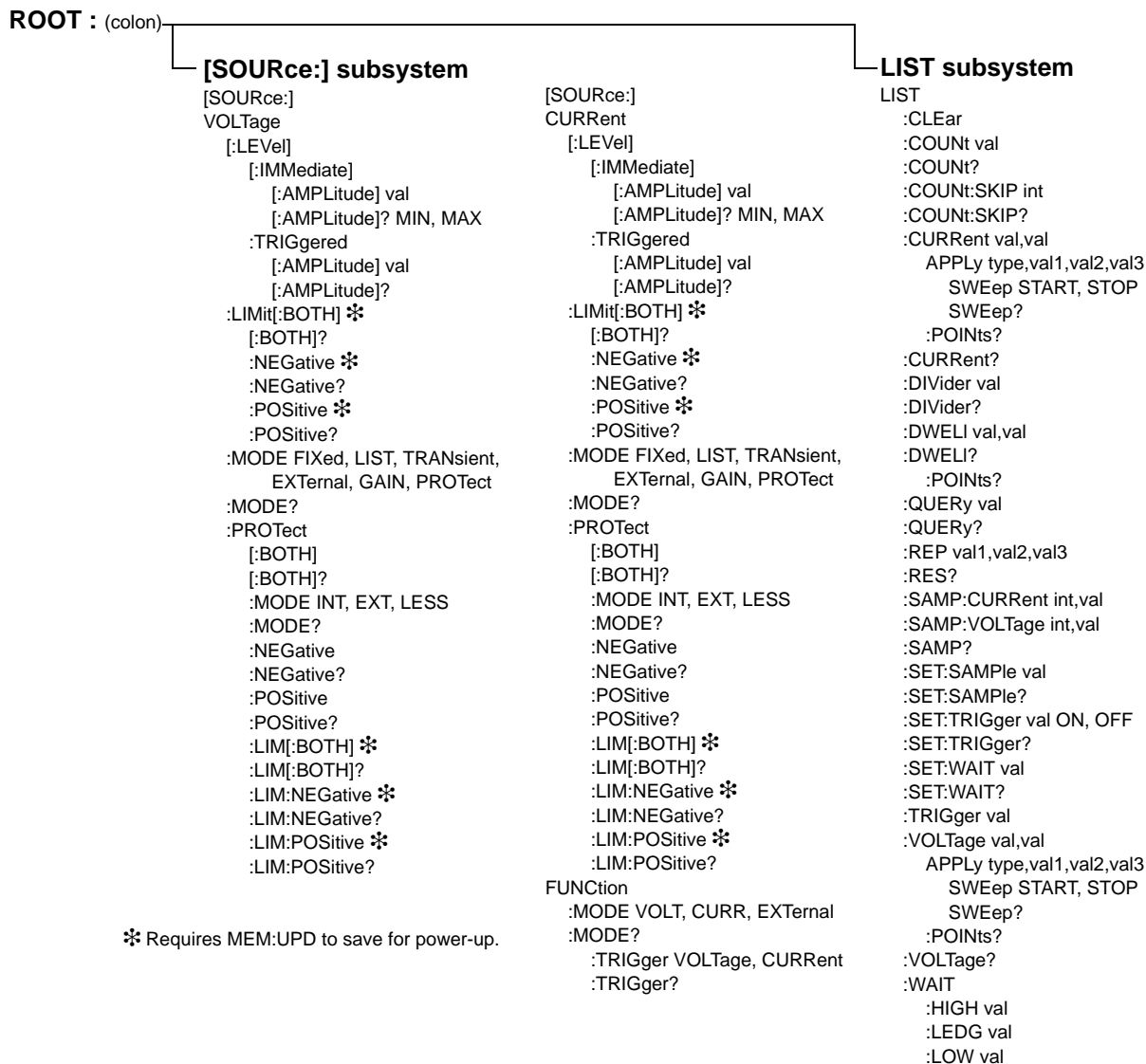

FIGURE 3-9. TREE DIAGRAM OF SCPI COMMANDS USED WITH BOP POWER SUPPLY (SHEET 2 OF 2)

### 3.7.3.7 STATUS SUBSYSTEM

This subsystem programs the power supply status register. The power supply has two groups of status registers: Operation and Questionable. Each group consists of three registers: Condition, Enable, and Event.

### 3.7.3.8 TRIGGER SUBSYSTEM

This subsystem controls the remote triggering of the power supply.

### 3.7.3.9 [SOURCE:]VOLTAGE AND [SOURCE:]CURRENT SUBSYSTEMS

These subsystems program the output voltage and current of the power supply.



### **3.7.3.10 CALIBRATE SUBSYSTEM**

The BOP series of power supplies support software calibration. A full calibration consist of a voltage calibration and a current calibration. These calibration procedures include steps that prepare the unit for series or parallel operation. Both voltage and current calibrations consist of a zero (performed on the main channels only) and positive and negative full scale calibrations with both internal and external references. In addition, the external reference and variable gain are also calibrated. Calibration is performed by sending commands through the GPIB or RS 232 interface.

In order to enter the calibration mode the correct calibration access code (password) must be entered. If the password has been forgotten, refer to PAR. 3.7.3.11.1 to reset the password. During the calibration, new calibration data is computed which is than stored in the non volatile memory.

Refer to PAR. 4.2 for calibration equipment requirements.

During voltage calibration, the voltage, voltage protect and voltage readback are calibrated and during current calibration the current, current protect and current readback are calibrated. The normal procedure is to calibrate voltage first and then current. However, you do not have to do a complete calibration each time. If required, you may calibrate only the voltage or the current and then proceed to saving the calibration results. For voltage calibration all loads must be disconnected and the sense terminals connected to the corresponding output terminals. The digital voltmeter will be connected to the sensing terminals (OUT S and COM S) of the power supply. For current calibration after disconnecting all loads an appropriate shunt resistor will be connected across output terminals and the digital voltmeter will be connected across the sense terminals of the shunt resistor. Other high-precision and high-stability current measurement devices (such as a zero flux current transducer) also can be used for output current calibration and evaluation.

### **3.7.3.11 SYSTEM SUBSYSTEM**

This subsystem controls system-level commands, including setup of the GPIB and Serial ports, error queries, front panel setup (keyboard lockout, display illumination, and audible beeps), passwords, command language, setup of device clear, line feed and reset, and restoring factory calibration.

#### **3.7.3.11.1 FORGOTTEN PASSWORDS**

If the password is lost, contact the factory.

### 3.7.4 PROGRAM MESSAGE STRUCTURE

SCPI program messages (commands from controller to power supply) consist of one or more *message units* ending in a *message terminator*. The message terminator is not part of the syntax; it is defined by the way your programming language indicates the end of a line (“newline” character). Sending a character with EOL line asserted is another way of sending a message terminator. The message unit is a keyword consisting of a single command or query word followed by a message terminator (e.g., CURR?<newline> or TRIG<end-of-line>). The message unit may include a data parameter after the keyword separated by a space; the parameter is usually numeric (e.g., CURR 5<newline>), but may also be a string (e.g., OUTP ON<newline>). Figure 3-10 illustrates the message structure, showing how message units are combined. The following subparagraphs explain each component of the message structure.

NOTE: An alternative to using the message structure for multiple messages defined in the following paragraphs is to send each command as a separate line. In this case each command must use the full syntax shown in Appendix B.

#### 3.7.4.1 KEYWORD

Keywords are instructions recognized by a decoder within the BOP, referred to as a “parser.” Each keyword describes a command function; all keywords used by the BOP are listed in Figure 3-9.

Each keyword has a long form and a short form. For the long form the word is spelled out completely (e.g. STATUS, OUTPUT, VOLTAGE, and TRIGGER are long form keywords). For the short form only the first three or four letters of the long form are used (e.g., STAT, VOLT, OUTP, and TRIG). The rules governing short form keywords are presented in Table 3-11.

**TABLE 3-11. RULES GOVERNING SHORTFORM KEYWORDS**

IF NUMBER OF LETTERS IN LONGFORM KEYWORD IS:	AND FOURTH LETTER IS A VOWEL?	THEN SHORT FORM CONSISTS OF:	EXAMPLES
4 OR FEWER	(DOES NOT MATTER)	ALL LONG FORM LETTERS	MODE
5 OR MORE	NO	THE FIRST FOUR LONG FORM LETTERS	MEASure, OUTPut, EVENt
	YES	THE FIRST THREE LONG FORM LETTERS	LEVel, IMMEDIATE, ERRor

You must use the rules above when using keywords. Using an arbitrary short form such as ENABL for ENAB (ENABLE) or IMME for IMM (IMMEDIATE) will result in an error. Regardless of which form chosen, you must include all the letters required by that form.

To identify the short form and long form in this manual, keywords are written in upper case letters to represent the short form, followed by lower case letters indicating the long form (e.g., IMMEDIATE, EVENt, and OUTPut). The parser, however, is not sensitive to case (e.g., outp, OUTP, OUTPUt, ouTPut, or OUTp are all valid).

#### 3.7.4.2 KEYWORD SEPARATOR

If a command has two or more keywords, adjacent keywords must be separated by a colon (:) which acts as the keyword separator (e.g., CURR:LEV:TRIG). The colon can also act as a root specifier (paragraph 3.7.4.7).

### 3.7.4.3 QUERY INDICATOR

The question mark (?) following a keyword is a query indicator. This changes the command into a query. If there is more than one keyword in the command, the query indicator follows the last keyword. (e.g., VOLT? and MEAS:CURR?).

### 3.7.4.4 DATA

Some commands require data to accompany the keyword either in the form of a numeric value or character string. Data always follows the last keyword of a command or query (e.g., VOLT:LEV:TRIG 14 or SOUR:VOLT? MAX

### 3.7.4.5 DATA SEPARATOR

Data must be separated from the last keyword by a space (e.g., VOLT:LEV:TRIG 14 or SOUR:VOLT? MAX

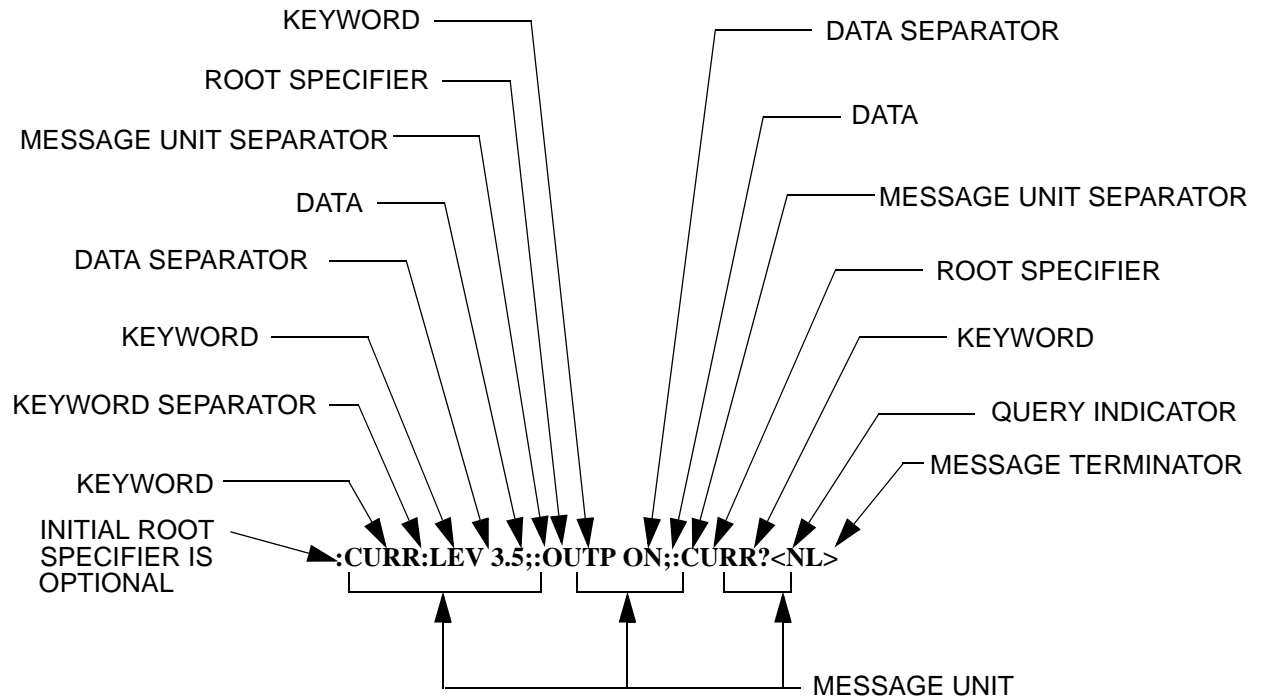

FIGURE 3-10. MESSAGE STRUCTURE

### 3.7.4.6 MESSAGE UNIT SEPARATOR

When two or more message units are combined in a program message, they must be separated by a semicolon (;) (e.g., VOLT 15;MEAS:VOLT? and CURR 12; CURR:TRIG 12.5).

### 3.7.4.7 ROOT SPECIFIER

The root specifier is a colon (:) that precedes the first keyword of a program message. This places the parser at the root (top left, Figure 3-9) of the command tree. Note the difference between using the colon as a keyword separator and a root specifier in the following examples:

VOLT:LEV:IMM 16 The root specifier is not necessary for the first keyword and has been omitted. Both colons are keyword separators.

:CURR:LEV:IMM 4 Even though it is not required, it is still correct to include the root specifier (first colon). The other two are keyword separators.

VOLT:LEV 6;;CURR:LEV 15 The root specifier for VOLT is not necessary because it is the first keyword in the string and has not been included. The second colon is the root specifier for CURR and is required; if it is missing an error will result. The first and third colons are keyword separators.

:INIT ON;;TRIG;;MEAS:CURR?;VOLT? The first three colons are root specifiers. The fourth colon is a keyword separator.

#### 3.7.4.8 MESSAGE TERMINATOR

The message terminator defines the end of a message. One message terminator is permitted:

- new line (<NL>), ASCII 10 (decimal) or 0A (hex)

NOTE: Kepco power supplies *require* a message terminator at the end of each program message. The examples shown in this manual assume a message terminator will be added at the end of each message. Where a message terminator is shown it is represented as <NL> regardless of the actual terminator character.

#### 3.7.5 UNDERSTANDING THE COMMAND STRUCTURE

Understanding the command structure requires an understanding of the subsystem command tree illustrated in Figure 3-9. The “root” is located at the top left corner of the diagram. The parser goes to the root if:

- a message terminator is recognized by the parser
- a root specifier is recognized by the parser

*Optional keywords* are enclosed in brackets [ ] for identification; optional keywords can be omitted and the power supply will respond as if they were included in the message. The root level keyword [SOURce] is an optional keyword. Starting at the root, there are various branches or paths corresponding to the subsystems. The root keywords for the BOP Power Supply are :ABORt, :CALibrate, :DISPlay, :INITiate, :LIST, :MEASure, :OUTPut, [:SOURce], :STATus, :SYSTem and :TRIGger. Because the [SOURce] keyword is optional, the parser moves the path to the next level, so that VOLTage, CURRent, and FUNCtion commands are at the root level.

Each time the parser encounters a keyword separator, the parser moves to the next indented level of the tree diagram. As an example, the STATus branch is a root level branch that has three sub-branches: OPERation, PRESet, and QUEStionable. The following illustrates how SCPI code is interpreted by the parser:

**STAT:PRES<NL>**

The parser returns to the root due to the message terminator.

**STAT:OPER?;PRES<NL>**

The parser moves one level in from STAT. The next command is expected at the level defined by the colon in front of OPER?. Thus you can combine the following message units STAT:OPER? and STAT:PRES;

### **STAT:OPER:COND?;ENAB 16<NL>**

After the OPER:COND? message unit, the parser moves in one level from OPER, allowing the abbreviated notation for STAT:OPER:ENAB.

## **3.7.6 PROGRAM MESSAGE SYNTAX SUMMARY**

- Common commands begin with an asterisk (\*).
- Queries end with a question mark (?).
- Program messages consist of a root keyword and, in some cases, one or more message units separated by a colon (:) followed by a message terminator. Several message units of a program message may be separated by a semicolon (;) without repeating the root keyword.
- If a program message has more than one message unit, then a colon (:) must precede the next keyword in order to set the parser back to the root (otherwise the next keyword will be taken as a subunit of the previous message unit).

e.g., the command **meas:volt?;curr?** will read output voltage and output current since both **volt?** and **curr?** are interpreted as subunits of the **meas** command.

- Several commands may be sent as one message; a line feed terminates the message. Commands sent together are separated by a semicolon (;). The first command in a message starts at the root, therefore a colon (:) at the beginning is not mandatory. E.g., the command **meas:volt?;curr?** will read output voltage and output current, however the command **meas:volt?::curr?** will read actual output voltage and programmed current since the colon preceding **curr?** indicates that **curr?** is not part of the **meas** command and starts at the root.
- UPPER case letters in mnemonics are mandatory (short form). Lower case letters may either be omitted, or must be specified completely (long form)  
e.g., **INSTrument** (long form) has the same effect as **INST** (short form).
- Commands/queries may be given in upper/lower case (long form)  
e.g., **SoUrCe** is allowed.
- Text shown between brackets [ ] is optional.  
e.g., **:[SOUR]VOLT:[LEV] TRIG** has the same effect as **:VOLT TRIG**

## **3.7.7 STATUS REPORTING**

The status reporting of the BOP power supply follows the SCPI and IEEE 488.2 requirements. The serial poll response of the BOP power supply provides summary bits of the status and error reporting system. The simplest status report is the command valid reporting and data availability. This successful decoding of a command string generates no error and is indicated by the bit 3 of the serial poll response being a zero. The setting of bit 4 in the status byte indicates data is available to the controller in response a command query message.

### **3.7.7.1 STATUS REPORTING STRUCTURE**

The status reporting of the BOP uses four status registers, illustrated in Figure 3-11. These registers are the Questionable, Operation, Standard Event and Service Request registers. The Questionable and Operation registers are 16 bit registers and the Standard Event and Service

Request registers are 8 bits. These four registers are referred to as condition registers. Each of the four condition registers is associated with two related registers: an event register which holds unlatched events reported in real-time by the instrument and is cleared by reading the register, and an enable register which allows the contents of the event register to be passed through to set the associated condition register.

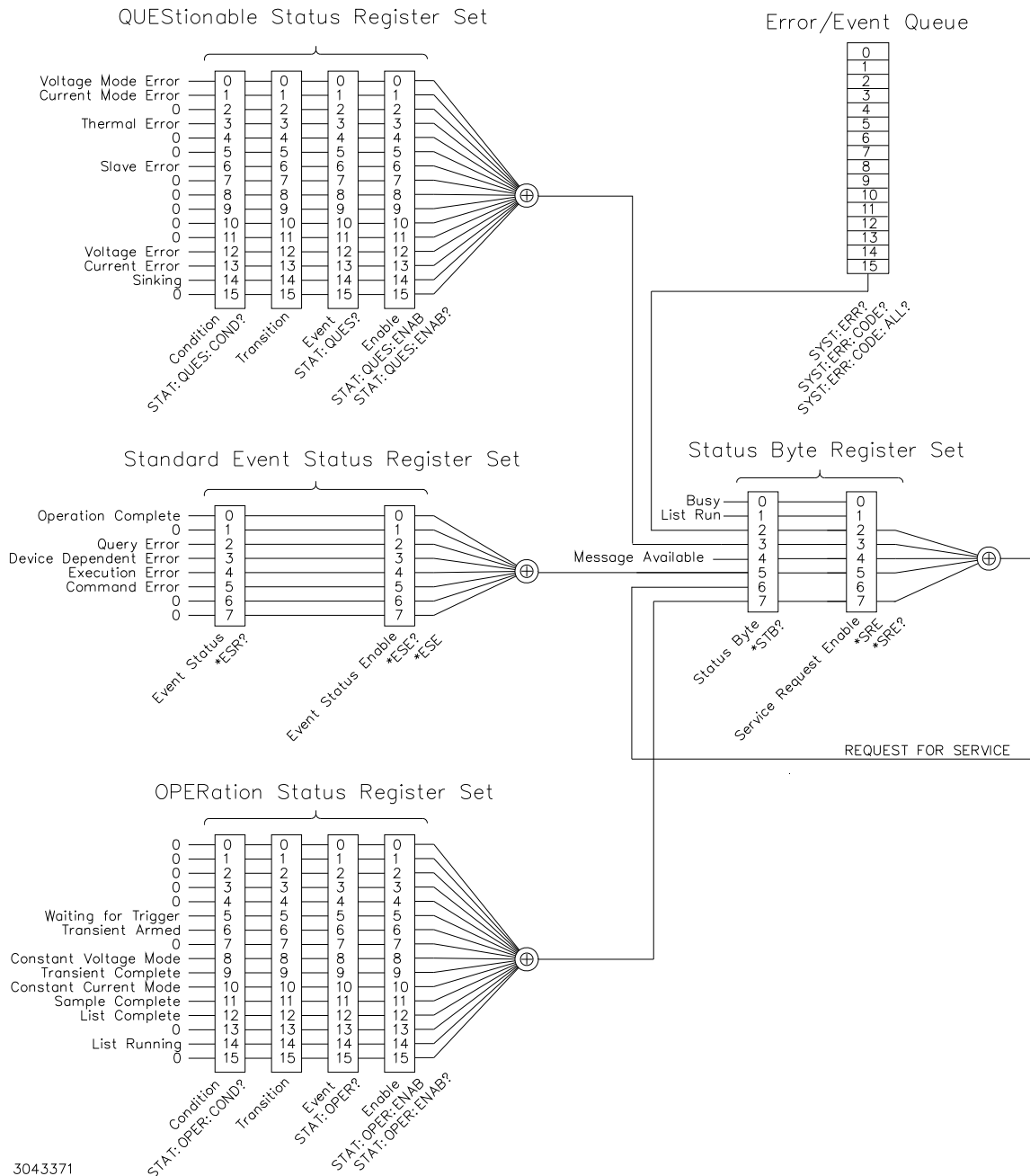

3043371

FIGURE 3-11. STATUS REPORTING STRUCTURE

A zero to one transition of a condition register is added to the event register. Reading an event register clears all of the bits found in the event register. If any bits are set in an event register, the following condition register bit is then set. For example, if the STAT:QUES:ENB (enable) register has bit 0 set and a voltage error is detected, the event registers bit 0 is set. The 1 in the event register causes bit 3 of the status byte to be asserted. The Service Request register is ANDed with its enable register for all bits except bit 6. The result is placed in bit 6 of the Service Request register. If bit 6 is a 1 (true), it causes the MBT-G power supply to assert the SRQ line to the host controller.

Figure 3-11 also shows that if the error/event queue is not empty, bit 3 is set in the Service Request register and bit 4 indicates that a message is available in the output buffer.

### 3.7.7.2 OPERATIONAL STATUS REGISTER

The OPERational condition register contains conditions which are a part of the instrument's normal operation. The definition of each of these bits (condition register) is as follows:

- 0 through 4 - Not Used — always zero.
- 5 - Waiting for Trigger — 1 indicates the trigger system is enabled. If trigger source is external and the trigger input goes low, the WTG will remain in a one condition until after the trigger input goes high.
- 6 - Transient Armed — 1 indicates the transient function is enabled,
- 7 - Not Used — always zero.
- 8 - Constant Voltage — 1 indicates the instrument is in constant voltage mode.
- 9 - Transient Complete — 1 indicates transient has been completed. Not readable in OPERation Status Condition register.
- 10 - Constant Current — 1 indicates the instrument is in constant current mode.
- 11 - Sample Complete — 1 indicates the sample has been completed.
- 12 - List Complete — 1 indicates the programmed list has been completed. Not readable in OPERation Status Condition register.
- 13 - Not Used — always zero.
- 14 - List Running — 1 indicates the programmed list is in progress.
- 15 - Not Used — always zero.

### 3.7.7.3 QUESTIONABLE STATUS REGISTER

The QUEStionable condition register (see Figure 3-11) contains status bits representing data/signals which give an indication of the quality of various aspects of the signal.

A bit set in the QUEStionable condition register indicates that the data currently being acquired or generated is of questionable quality due to some condition affecting the parameter associated with that bit.

- 0 - Voltage Mode Error — 1 indicates the instrument is in Current mode.
- 1 - Current Mode Error — 1 indicates the Power Supply is in Voltage mode.
- 2 - Not Used — always zero.
- 3 - Thermal Error — 1 indicates a thermal error has been detected.

- 4 - 5 - Not Used — always zero.
- 6 - Slave Error — 1 indicates a slave fault in a master/slave configuration
- 7 - 11 - Not Used — always zero.
- 12 - Voltage Protect Error — 1 indicates a Voltage protection error has been detected.

NOTE: If External Reference is enabled and a protection error occurs, both Voltage Protect Error (bit 12) and Current Protect Error (bit 13) are set

- 13 - Current Protect Error — 1 indicates a Current protection error has been detected.
- 14 - Sinking — 1 indicates the unit is absorbing energy from the load.
- 15 Not Used — always zero.

### 3.7.8 SCPI PROGRAM EXAMPLES

Refer to Appendix B, Figures B-1 through B-13 for examples illustrating the use of SCPI commands.

Figure 3-12 is an example of a program using SCPI commands to program the BOP Power Supply. The program illustrated is for a configuration using an IBM PC or compatible with a National Instruments GPIB interface card. (It will be necessary to consult the manufacturer's data to achieve comparable functions with an interface card from a different manufacturer.) This program sets output voltage (Voltage mode) or voltage limit (Current mode) to 5V, and current limit (Voltage mode) or output current (Current mode) to 1A, then reads the measured (actual) voltage and current, then prints the measurements.

### 3.8 OPERATOR TROUBLESHOOTING

If the unit does not behave as expected, refer to the following procedure for problems that can be corrected without referring the unit for repair. Refer to Figure 2-2 for power-up switch locations.

1. Immediately after power-up, if the unit beeps in groups of two, power-up switch S2 is incorrectly set up. If the unit beeps in groups of three, power-up switch S3 is improperly setup. If it is beeping on and off, power-up switch S1 is incorrectly set up. Verify that power up-switches are set to the proper configuration. If necessary, turn unit off, reset switches and turn power on again.
2. Verify all connections are properly wired and connections are tight.
3. If the MASTER/SLAVE LED is blinking - Is this a unit with a slave attached? if not, power off unit and set Switch S2 to 00001 (S2-1 to on, all the rest off). Power up unit.
4. Verify that saved parameter(s) are not overriding the power-up switches by sending queries for each power-up parameter to verify it is set to the configuration indicated by the power-up switches. (NOTE: It is recommended that parameters saved using MEM:UPD be noted on the unit to avoid unexpected behavior.)
  - a. If querying the power-up parameters is not possible or not easily performed, reset the limits by first recording the current power-up switch settings, then performing a reset power-up per PAR. 3.3.2.1.



- b. After the unit powers up and the POWER/FAULT/LIMIT light is green and the unit is beeping equally, on and off, turn the unit off.
- c. Return switches to previously recorded positions from step 4a above and perform a normal power-up per PAR. 3.3.2.2.

```

/*****
/*  Sample Program For KEPCO power supply, using National Instruments  */
/*  GPIB interface card and IBM PC or compatible computer          */
/*****

#include <stdio.h>
#include "decl.h"

char rd_str[80];           // Input buffer
char dat_str[80];        // Output buffer
int bd,adr;

main() {
    adr = ibfind("DEV6");           // Open DEV6 (defined by IBCONF)
    bd = ibfind ("GPIB0");         // Open GPIB card
    ibsic (bd);                    // Send Interface Clear
    ibsre(bd,1);                   // Set remote line true

    strcpy(dat_str,"VOLT 5;CURR 1"); // Define a set command
    strcat(dat_str,"\r\n");         // Append delimiter
    ibwrt(adr,dat_str,strlen(dat_str)); // Send string to power supply

    strcpy(dat_str,"MEAS:VOLT?;CURR?"); // Define a measure command
    strcat(dat_str,"\r\n");         // Append delimiter
    ibwrt(adr,dat_str,strlen(dat_str)); // Send string to power supply

    strset(rd_str,'\0');           // Clear input buffer
    ibrd(adr,rd_str,64);           // Read result of measure
    printf("received : %s\n",rd_str); // Print voltage and current
}

```

**FIGURE 3-12. TYPICAL EXAMPLE OF BOP POWER SUPPLY PROGRAM USING SCPI COMMANDS**



## SECTION 4 - CALIBRATION

### 4.1 GENERAL

This section contains the calibration instructions for the Power Supply. It is recommended that the user be familiar with operation of the unit (PAR's. 3.3 and 3.5) before calibrating the unit.

A full calibration consist of a voltage calibration and a current calibration. Both voltage and current calibrations consist of zero, max and min, and protection limit calibration. In addition, the control signals required for series and parallel operation of multiple units are also calibrated. It is recommended that the unit be recalibrated annually.

In order to enter the calibration mode the correct password may be required (see PAR. 3.5.1). If the password has been lost, call the factory and a special password will be provided. During the calibration, new calibration data is computed which is then stored in the nonvolatile memory.

Calibration of the BOP is performed remotely by sending commands through either the GPIB or RS 232 bus (PAR. 4.3).

NOTE: During calibration, various circuits of the BOP are verified. If an error occurs during the verification process, the unit will beep and an error 24(x), Hardware, (see PAR. B.134) will be placed in the error queue.

**TABLE 4-1. CALIBRATION SUMMARY**

Type	Step	Reference Type and Value	Monitored Parameter	Output Conditions	Notes
VOLTAGE INTERNAL	1. ZERO 2. POSITIVE 3. NEGATIVE	Internal	Output Voltage 1. 0.0v 2. +Voltage FS 3. -Voltage FS	NO LOAD AUTOMATIC VM	1. DVM between OUT S and COM S. 2. Adjust for zero, positive and negative FS. 3. Digital readback calibration is done automatically.
ANALOG READBACK OF OUTPUT VOLTAGE	1. ZERO 2. POSITIVE	Internal	Analog readback of Output voltage Pin 15 ref to pin 4 of Analog I/O port 1. Zero: 0.0V 2. F.S. +10.0V	NO LOAD AUTOMATIC VM	1. DVM between pins 15 and 4 of Analog I/O port/ 2. Manually adjust ZERO and FULL SCALE ADJ pots (see Figure 2-2).
VOLTAGE PROTECTION	1. POSITIVE 2. NEGATIVE	Internal	Output Voltage 1. +Voltage FS 2. -Voltage FS	NO LOAD AUTOMATIC CM	1. DVM between OUT S and COM S. 2. Adjust for positive and negative FS.
VOLTAGE EXTERNAL	1. ZERO 2. POSITIVE	External: 1. 0.0V 2. +10.0V (Analog I/O Port, pin 11 ref to pin 10)	Output Voltage 1. 0.0v 2. +Voltage FS	NO LOAD AUTOMATIC VM	1. DVM between OUT S and COM S. 2. Adjust for zero, positive FS.
VOLTAGE GAIN	1. ZERO 2. POSITIVE	External: 1. 0.0V 2. +10.0V (Analog I/O Port pin 11 ref to 10)	Output Voltage: 1. 0.0V 2. 0.0V	No Load Automatic VM	1. DVM between OUT S and COM S 2. Adjust for zero (both Zero and Positive).

**TABLE 4-1. CALIBRATION SUMMARY (CONTINUED)**

Type	Step	Reference Type and Value	Monitored Parameter	Output Conditions	Notes
EXTERNAL CONTROLS, SERIES	1. ZERO 2. POSITIVE	External: 1. 0.0V 2. -10.0V (Par/Ser CTRL-IN Port, pin 8 ref to COM S)	Output Voltage: 1. 0.0V 2. +10.0V	No Load Automatic VM	1. DVM between OUT S and COM S 2. Adjust for zero, +10.0V 3. Calibrate unit for Slave in Series
CURRENT, INTERNAL	1. ZERO 2. POSITIVE 3. NEGATIVE	Internal	Output Current: 1. 0.0A 2. +Current FS 3. -Current FS	Short with Meas. Shunt Automatic CM	1. DVM between probe terminals of Meas. Shunt (LO towards COM S) 2. Adjust for zero, positive and negative FS. 3. Digital readback calibration is done automatically.
CURRENT, PROTECTION	1. POSITIVE 2. NEGATIVE	Internal	Output Current: 1. +Current FS 2. -Current FS	Short with Meas. Shunt Automatic VM	1. DVM between probe terminals of Meas. Shunt (LO towards COM S) 2. Adjust for positive and negative FS.
CURRENT, EXTERNAL	1. ZERO 2. POSITIVE	External: 1. 0.0V 2. +10.0V (Analog I/O Port pin 11 ref to 10)	Output Current: 1. 0.0A 2. +Current FS	Short with Meas. Shunt Automatic CM	1. DVM between probe terminals of Meas. Shunt (LO towards COM S). 2) Adjust for zero, pos FS.
CURRENT, GAIN	1. ZERO 2. POSITIVE	External: 1. 0.0V 2. +10.0V (Analog I/O Port pin 11 ref to 10)	Output Current: 1. 0.0A 2. 0.0A	Short with Meas. Shunt Automatic CM	1. DVM between probe terminals of Meas. Shunt (LO towards COM S) 2. Adjust for zero (both Zero and Positive)
EXTERNAL CONTROLS, PARALLEL	1. ZERO 2. POSITIVE	External: 1. 0.0V 2. +10.0V (Par/Ser CTRL-IN Port pin3 ref. to pin1)	Output Current: 1. 0.0A 2. +Current FS	Short with Meas. Shunt Automatic CM	1. DVM between probe terminals of Meas. Shunt (LO towards COM S) 2. Adjust for zero, pos. FS 3. Calibrate unit for Slave in Parallel
EXTERNAL CONTROLS, I_OUT	1. ZERO 2. POSITIVE	INTERNAL	Voltage at Par/Ser CTRL-IN Port pin 6 ref. to pin1: 1. 0.0V 2. +10.0V	Short with Meas. Shunt Automatic CM	1. DVM at Par/Ser CTRL-IN Port pin 6 ref. to pin 1 2. Adjust for zero, +10.0V 3. Calibrate unit for Master in Parallel
EXTERNAL PROTECTION, Pos. Voltage Neg. Voltage Pos. Current Neg. Current (together)	1. ZERO 2. FULL SCALE	External: 1. 0.0V 2. +10.0V (Analog I/O Port pins 14, 6, 13, 5 ref to pin12)	N/A	No requirements	1. Automatic internal measurement

## 4.2 TEST EQUIPMENT REQUIREMENTS

Table 4-2 lists sense resistors recommended for measuring current and includes Kepco and Manufacturer's part numbers. The value of the sense resistor chosen should be known with 0.001% accuracy. If other than a recommended sense resistor is to be used, it must be rated for at least 100W power dissipation (actual power dissipation will be approximately 10W). The thermal coefficient of the sense resistor chosen should be 10 ppm/°C or better. Other high-precision and high-stability current measurement devices (such as a zero flux current transducer) can also be used for output current calibration and evaluation.

The digital voltmeter (DVM) used to measure output voltage and the voltage across the current sensing resistor should have at least six digits, multiple ranges, the smallest resolution must be at least one microvolt and the accuracy must be at least 0.0001%.

To calibrate the external programming capabilities of the BOP a DC reference voltage with the following minimum specifications is required.

- Value: 0.0V ±0.1mV and 10.0V ±0.1mV (either positive and negative or floating)
- Stability: better than 10<sup>-5</sup>
- Internal Impedance: better than 0.1 Ohms
- Output Current: >0.5mA when sourcing, >0.15mA when sinking

**TABLE 4-2. SUGGESTED SENSE RESISTORS**

MODEL	VALUE	KEPCO PART NO.	MANUFACTURER	MANUFACTURER PART NO.
BOP 6-125G BOP 10-75G BOP 10-100G BOP 20-50G BOP 25-40G BOP 36-28G	0.001 OHM	115-3033	ISOTEK	RUG-Z-R001-0.1 TK10
BOP 50-20G BOP 72-14G BOP 100-10G	0.01 OHM	115-2997	ISOTEK	RUG-Z-R010-0.1 TK10
NOTE: ALL SENSE RESISTORS MUST BE MOUNTED ON A HEATSINK WITH A MINIMUM SURFACE AREA OF 36 SQUARE INCHES TO MAINTAIN THERMAL STABILITY DURING CALIBRATION; FORCED COOLING IS RECOMMENDED. KEPCO HEATSINK P/N 136-0451 WILL PROVIDE ADQUATE COOLING FOR THE SENSE RESISTOR.				

**TABLE 4-3. VOLTAGE CALIBRATION MEASUREMENTS AND TOLERANCES**

MODEL	VOLTAGE ZERO	±FULL SCALE VOLTAGE	±FULL SCALE VPR LIMIT
BOP 6-125G	0V ±0.001V	6V (MAX) -6V (MIN) ±0.001V	6V (MAX) -6V (MIN) ±0.002V
BOP 10-75G BOP 10-100G	0V ±0.001V	10V (MAX) -10V (MIN) ±0.001V	10V (MAX) -10V (MIN) ±0.003V
BOP 20-50G	0V ±0.002V	20V (MAX) -20V (MIN) ±0.002V	20V (MAX) -20V (MIN) ±0.006V
BOP 25-40G	0V ±0.003V	25V (MAX) -25V (MIN) ±0.003V	25V (MAX) -25V (MIN) ±0.008V
BOP 36-28G	0V ±0.0036V	36V (MAX) -36V (MIN) ±0.0036V	36V (MAX) -36V (MIN) ±0.01V
BOP 50-20G	0V ±0.005V	50V (MAX) -50V (MIN) ±0.005V	50V (MAX) -50V (MIN) ±0.015V
BOP 72-14G	0V ±0.0072V	72V (MAX) -72V (MIN) ±0.0072V	72V (MAX) -72V (MIN) ±0.022V
BOP 100-10G	0V ±0.01V	100V (MAX) -100V (MIN) ±0.01V	100V (MAX) -100V (MIN) ±0.03V

**4.3 CALIBRATION USING REMOTE SCPI COMMANDS VIA GPIB OR RS 232 INTERFACE**

The primary means of adjustment are the **CAL:DATA** commands. Basically these commands are fine and coarse adjustments, however there are slight differences in how they work for different types of calibrations.

a. **ZERO Calibrations, main channel (voltage or current) (always done first).** The only means of adjustment is the **CAL:DATA <VALUE>** command which provides a total of 4095 increments of adjustment starting at 0, with 2047 increments in either direction to achieve maximum output levels of ±2.5% of  $E_{Onom}$  or  $I_{Onom}$ . Adjust the output to obtain the closest value to zero.

b. **MAX and MIN Calibrations, main channel (voltage or current).** The primary means of adjustment is the **CAL:DATA <VALUE>** command to either increase (**CAL:DATA 1**) or decrease (**CAL:DATA -1**) the output value. Adjustment can be done in larger increments by increasing the numeric value, e.g., **CAL:DATA +10** or **CAL:DATA -10**. Adjust the output to obtain the closest value above the full scale value.

c. **VPR and CPR Calibrations, limit channels (positive and negative voltage or current protection).** The only means of adjustment is the **CAL:DATA <VALUE>** command which provides a total of 4095 increments of adjustment from zero to maximum. Adjust the output to obtain the closest value above the full scale value.

**TABLE 4-4. CURRENT CALIBRATION MEASUREMENTS AND TOLERANCES**

MODEL	SENSE RESISTOR VALUE (SEE NOTE AND TABLE 4-2)	CURRENT ZERO	±FULL SCALE CURRENT	±FULL SCALE CPR LIMIT
BOP 6-125G	0.001 Ohm	0V (±0.0013mV)	0.125V (MAX) -0.125V (MIN) ±0.013mV	0.125V (MAX) -0.125V (MIN) ±0.062mV
BOP 10-75G	0.001 Ohm	0V (±0.008mV)	0.075V (MAX) -0.05V (MIN) ±0.008mV	0.075V (MAX) -0.075V (MIN) ±0.038mV
BOP 10-100G	0.001 Ohm	0V ±0.01mV	0.100V (MAX) -0.100V (MIN) ±0.01mV	0.100V (MAX) -0.100V (MIN) ±0.05mV
BOP 20-50G	0.001 Ohm	0V (±0.005mV)	0.05V (MAX) -0.05V (MIN) ±0.005mV	0.05V (MAX) -0.05V (MIN) ±0.025mV
BOP 25-40G	0.001 Ohm	0V (±0.004mV)	0.04V (MAX) -0.04V (MIN) ±0.004mV	0.04V (MAX) -0.04V (MIN) ±0.02mV
BOP 36-28G	0.001 Ohm	0V (±0.003mV)	0.028V (MAX) -0.028V (MIN) ±0.003mV	0.028V (MAX) -0.028V (MIN) ±0.014mV
BOP 50-20G	0.01 Ohm	0V (±0.02mV)	0.2V (MAX) -0.2V (MIN) ±0.02mV	0.2V (MAX) -0.2V (MIN) ±0.10mV
BOP 72-14G	0.01 Ohm	0V (±0.014mV)	0.14V (MAX) -0.14V (MIN) ±0.014mV	0.14V (MAX) -0.14V (MIN) ±0.07mV
BOP 100-10G	0.01 Ohm	0V (±0.01mV)	0.1V (MAX) -0.1V (MIN) ±0.01mV	0.1V (MAX) -0.1V (MIN) ±0.05mV
REFER TO NOTES FOR SENSE RESISTOR VALUE OTHER THAN LISTED HERE	R <sub>SENSE</sub> SEE NOTE.	SEE NOTE A.	SEE NOTE B.	SEE NOTE C.
USE SPACE PROVIDED AT RIGHT FOR CALCULATED VALUES.				

**NOTES:** The following formulas are used to calculate proper calibration values for Sense Resistors other than those recommended.

R<sub>SENSE</sub> = the measured value of the sense resistor in ohms (0.001% accuracy).

I<sub>Onom</sub> = Nominal (rated) current output of BOP in Amperes (e.g., for BOP 50-20M, I = 20A)

**A.** 0V, Tolerance = ±(R<sub>SENSE</sub>) × (0.1) × (I<sub>Onom</sub>) -- result in mV.

**B.** (R<sub>SENSE</sub>) × (I<sub>Onom</sub>) -- result in V, Tolerance = ±(R<sub>SENSE</sub>) × (0.1) × (I<sub>Onom</sub>) -- result in mV.

**C.** (R<sub>SENSE</sub>) × (I<sub>Onom</sub>) -- result in V, Tolerance = ±(R<sub>SENSE</sub>) × (0.5) × (I<sub>Onom</sub>) -- result in mV.

### 4.3.1 CALIBRATION PROCEDURE USING SCPI COMMANDS

The following procedure provides a complete calibration of the unit. Steps 19 and 20 calibrate the control signal used when the unit is a slave in series configurations. Steps 31 and 32 calibrate the control signal used when the unit is a master in parallel configurations. Steps 33 and 34 calibrate the control signal used when the unit is a slave in parallel configurations. There is no need for a special calibration step when the unit is used as a master in series configurations since the BOP output voltage (which is calibrated by this procedure) is used to control the next unit in series.

- NOTES:
1. **The unit will not calibrate unless the unit was turned on with power-up switch S2 segments set to 00001. If necessary, turn the unit off, set S2 to 00001 (standalone) and turn the unit on.**
  2. For ZERO calibration, adjust output to obtain value closest to zero.
  3. For FULL SCALE calibration adjust the output to obtain the closest value above the nominal full scale value.
  4. Set the unit for local sensing with GND Network in (see Figure 4-1) and disconnect load from BOP output to prepare the unit for voltage calibration.

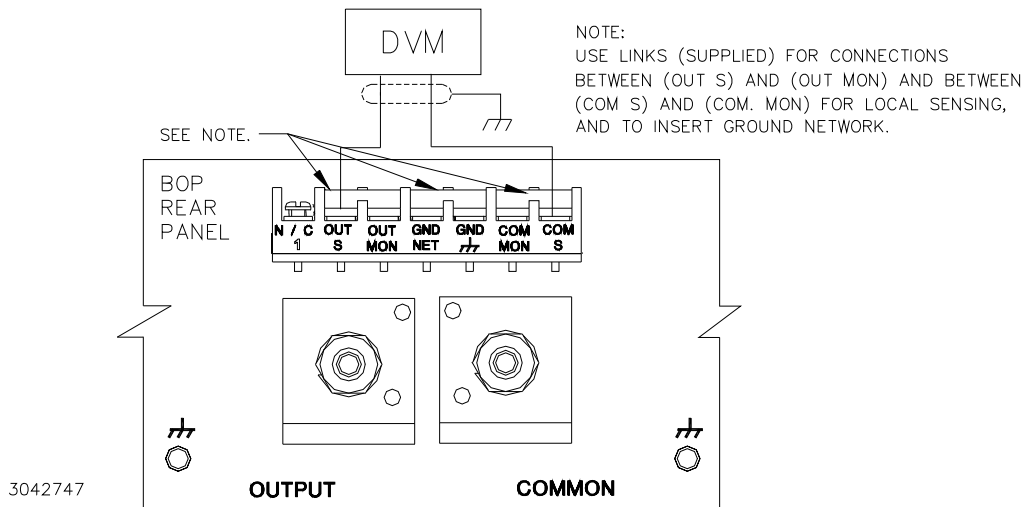

**FIGURE 4-1. CALIBRATION SETUP IN VOLTAGE MODE**

1. Initiate calibration by sending the SCPI command **SYSTEM:PASSWORD:CENable DEFAULT** and then send **CAL:STATE 1**. The password **DEFAULT** has been set at the factory. If the password has been changed from **DEFAULT**, substitute the correct password for the unit in the **SYST:PASS:CEN** command. If the password has been lost, consult factory.
2. Set the BOP to zero volts output by sending **CAL:VOLT ZERO**. Connect a Digital Voltmeter (DVM) to the BOP OUT S and COM S terminals to measure the output voltage. Send **CAL:DATA** commands as needed (see PAR. 4.3a) to adjust the BOP output until the DVM reads as close to zero as possible within tolerance specified in Table 4-3 for VOLTAGE ZERO.



3. Move the DVM to pin 15 referenced to pin 4 of the Analog I/O port. Using an adjustment screwdriver, adjust the ZERO ADJ pot (see Figure 2-2) until the DVM reads  $0V \pm 1mV$ . Restore the DVM across OUT S and COM S as shown in Figure 4-1.
4. Set the BOP to maximum positive output voltage by sending **CAL:VOLT MAX**. Measure the voltage output using the DVM. To adjust, send **CAL:DATA** commands as needed (see PAR. 4.3b) until the DVM reading is as close as possible above the nominal full scale value within the tolerance specified in Table 4-3 for +FULL SCALE VOLTAGE.
5. Move the DVM to pin 15 referenced to pin 4 of the Analog I/O port. Using an adjustment screwdriver, adjust the FULL SCALE ADJ pot (see Figure 2-2) until the DVM reads  $+10V \pm 1mV$ . Restore the DVM across OUT S and COM S as shown in Figure 4-1.
6. Set the BOP to maximum negative output voltage by sending **CAL:VOLT MIN**. To adjust, send the **CAL:DATA** command as needed (see PAR. 4.3b) until the reading is as close as possible above (absolute value) the nominal full scale value within the limits specified in Table 4-3 for –FULL SCALE VOLTAGE.
7. Send **CAL:VPR MAX** to adjust the maximum positive voltage protection limit of the power supply. Send the **CAL:DATA** commands as needed (see PAR. 4.3c) until the reading is as close as possible above the nominal full scale value within the limits specified in Table 4-3 for +FULL SCALE VPR LIMIT.
8. Send **CAL:VPR MIN** to adjust the maximum negative protection limit of the power supply. Send the **CAL:DATA** commands as needed (see PAR. 4.3c) until the reading is as close as possible above (absolute value) the nominal full scale value within the limits specified in Table 4-3 for –FULL SCALE VPR LIMIT.
9. Connect a  $0V \pm 0.1mV$  d-c reference to pin 11 (EXT\_REF) referenced to pin 10 (SGND) of the Analog I/O Port connector (A2A5J6). Set the BOP to zero volts output by sending **CAL:VEXT ZERO**. Send **CAL:DATA** commands as needed (see PAR. 4.3a) to adjust the BOP output voltage until the DVM reads as close to zero as possible within tolerance specified in Table 4-3 for VOLTAGE ZERO.

NOTE: Accuracy of the 10V d-c reference must be  $\pm 0.1mV$  in order for the calibrated unit to meet published specifications.

10. Replace 0V reference at pin 11 (EXT\_REF) of the Analog I/O Port connector (A2A5J6) with a +10V d-c reference. Set the BOP to maximum positive output voltage by sending **CAL:VEXT MAX**. Measure the output voltage using the DVM. To adjust, send **CAL:DATA** commands as needed (see PAR. 4.3b) until the DVM reading is as close as possible above the nominal full scale value within the tolerance specified in Table 4-3 for +FULL SCALE VOLTAGE.
11. Replace +10V reference at pin 11 (EXT\_REF) of the Analog I/O Port connector (A2A5J6) with a  $0V \pm 0.1mV$  d-c reference. Set the BOP to zero volts output by sending **CAL:VGA ZERO**. Send **CAL:DATA** commands as needed (see PAR. 4.3a) to adjust the BOP output until the DVM reads as close to zero as possible within tolerance specified in Table 4-3 for VOLTAGE ZERO.
12. Replace 0V reference at pin 11 (EXT\_REF) of the Analog I/O Port connector (A2A5J6) with a +10V d-c reference. Set the BOP to maximum positive output voltage by sending

**CAL:VGA MAX.** Measure the output voltage using the DVM. To adjust, send **CAL:DATA** commands as needed (see PAR. 4.3a) until the DVM reading is as close to zero as possible within tolerance specified in Table 4-3 for VOLTAGE ZERO.

13. Set the BOP to zero volts output by sending **CAL:ZERO**. Disconnect the +10V d-c reference voltage from the analog I/O port external reference pin (A2A5J6 pin 11) of the BOP, then connect 0V  $\pm$ 0.1mV d-c reference voltage from the external voltage source to +V\_LIM\_EXT (pin 14), -V\_LIM\_EXT (pin 6), +I\_LIM-EXT (pin 13) and -I\_LIM-EXT (pin 5) referenced to pin 12 (GND1) of the BOP analog I/O connector (A2A5J6), then send the **VLIM:ZERO** command followed by the **CAL:ZERO** command. This enables the BOP to recognize that the voltage at the  $\pm$ V\_LIM\_EXT pin is 0V.
14. Set the BOP to zero amperes output by sending **CAL:CLIM ZERO**. Then send the **CAL:ZERO** command. This enables the BOP to recognize that the voltage at the  $\pm$ I\_LIM-EXT pin is 0V.
15. Connect +10.0V  $\pm$ 0.1mV d-c reference voltage from the external voltage source to +V\_LIM\_EXT (pin 14), -V\_LIM\_EXT (pin 6), +I\_LIM-EXT (pin 13) and -I\_LIM-EXT (pin 5) referenced to pin 12 (GND1) of the BOP analog I/O connector (A2A5J6), then send **CAL:VLIM MAX**, then **CAL:ZERO** commands. This enables the BOP to recognize that the voltage at the +V\_LIM\_EXT pin is 10.0V.
16. Send **CAL:CLIM MAX**, then **CAL:ZERO** commands. This enables the BOP to recognize that the voltage at the +I\_LIM-EXT pin is 10.0V.
17. Set the BOP to minimum (maximum negative) output by sending **CAL:VLIM MIN**, then send the **CAL:ZERO** command. This enables the BOP to recognize that the voltage at the -V\_LIM\_EXT pin is 10.0V.
18. Set the BOP to minimum (maximum negative) output by sending **CAL:CLIM MIN**, then send the **CAL:ZERO** command. This enables the BOP to recognize that the voltage at the -I\_LIM-EXT pin is 10.0V.
19. Connect a 0V  $\pm$ 0.1mV d-c reference to pin 8 (S\_IN\_SERIAL) of the PAR/SER CONTROL IN connector (A2A5J3) referenced to COM S terminal at the rear panel (use mating connector supplied with the unit, P/N 142-0488 to gain access to PAR/SER CONTROL IN connector pins). Set the BOP to zero volts output by sending **CAL:SER ZERO**. Connect the DVM to the BOP OUT S and OUT COM terminals and send **CAL:DATA** commands as needed (see PAR. 4.3a) to adjust the BOP output until the DVM reads as close to zero as possible within tolerance specified in Table 4-3 for VOLTAGE ZERO.

NOTE: Accuracy of the 10V d-c reference must be  $\pm$ 0.1mV in order for the calibrated unit to meet published specifications.

20. Connect a -10V  $\pm$ 0.1mV d-c reference to pin 8 (S\_IN\_SERIAL) of the PAR/SER CONTROL IN connector (A2A5J3) referenced to COM S terminal at the rear panel. Set the BOP to maximum positive output voltage by sending **CAL:SER MAX**. Measure the voltage output using the DVM. Send **CAL:DATA** commands as needed (see PAR. 4.3b) until the DVM reading is as close as possible to +10V.
21. Send **CAL:ZERO** to prepare for current calibration. After sending the command, the BOP output will be set to zero volts. Refer to Figure 4-2 to connect the C terminals of the Kelvin type

sense resistor to the BOP and connect the DVM to the P (probe) terminals of the sense resistor ((LO terminal of DVM to common P terminal). Table 4-4 provides recommended sense resistor values for various BOP current outputs, as well as the formula for calculating expected measured values and tolerances for any sense resistor other than those recommended. Table 4-2 lists Kepeco and Manufacturer part numbers for those sense resistors recommended.

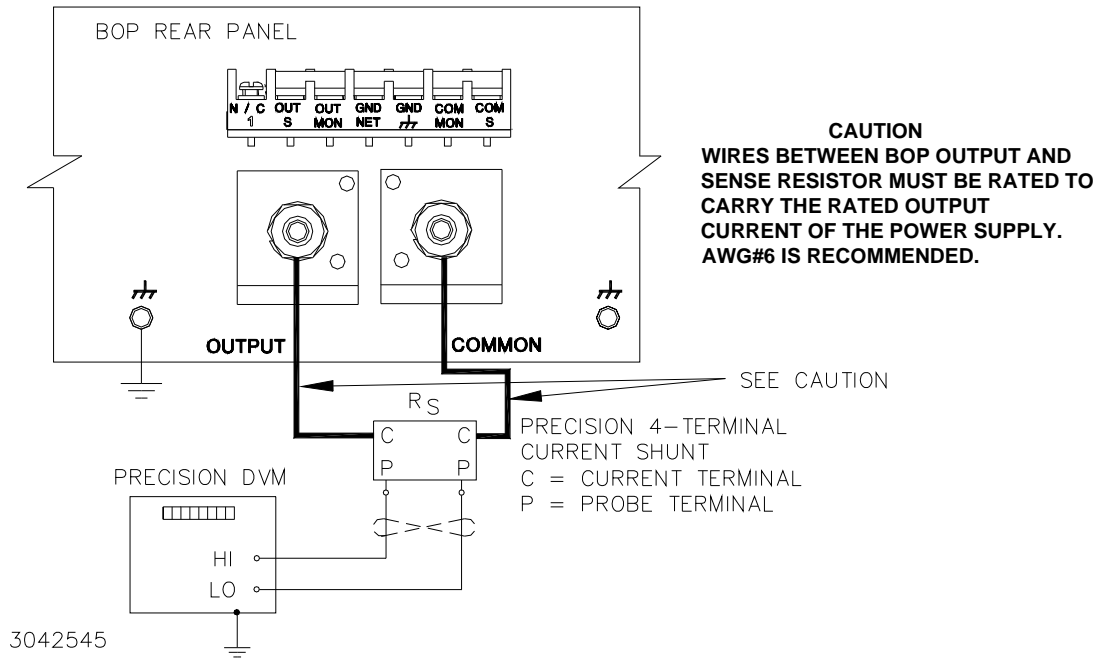

**FIGURE 4-2. CALIBRATION SETUP IN CURRENT MODE**

22. Set the BOP to zero volts across the sense resistor (corresponding to zero current) by sending `CAL:CURR ZERO`. Send `CAL:DATA` commands as needed (see PAR. 4.3a) until the reading is as close to zero as possible within the limits specified in Table 4-4 for CURRENT ZERO.

**WARNING**

**The sense resistor will be dissipating full rated current of the BOP. If it is hot to the touch, the sense resistor value, power rating and/or cooling are incorrect; refer to PAR. 4.3 and Table 4-2.**

23. Set the BOP to maximum positive output current by sending `CAL:CURR MAX`. Measure the current by reading the voltage across the sense resistor. To adjust, send `CAL:DATA` com-

mands as needed (see PAR. 4.3b) to adjust the BOP output until the DVM reads as close as possible above the nominal full scale value within tolerance specified in Table 4-4 for +FULL SCALE CURRENT.

24. Set the BOP to maximum negative output current by sending **CAL:CURR MIN**. Continue to measure the output current of the supply using the DVM connected to the sense resistor. To adjust, send **CAL:DATA** commands as needed (see PAR. 4.3b) to adjust the BOP output until the DVM reads as close as possible above (absolute value) the nominal full scale value within tolerance specified in Table 4-4 for –FULL SCALE CURRENT.
25. Send **CAL:CPR MAX** to adjust the maximum positive current protection limit of the power supply. To adjust, send **CAL:DATA** commands as needed (see PAR. 4.3c) to adjust the BOP output until the DVM reads as close as possible above the nominal full scale value within tolerance specified in Table 4-4 for +FULL SCALE CPR LIMIT.
26. Send **CAL:CPR MIN** to adjust the minimum (maximum negative) current protection limit of the power supply. To adjust, send **CAL:DATA** commands as needed (see PAR. 4.3c) to adjust the BOP output until the DVM reads as close as possible above (absolute value) the nominal full scale value within tolerance specified in Table 4-4 for –FULL SCALE CPR LIMIT.
27. Send **CAL:ZERO** to set the BOP output to zero. Connect  $0V \pm 0.1mV$  d-c reference voltage to external reference pin 11 referenced to pin 10 (SGND) of the BOP analog I/O port (A2A5J6). Set the BOP to zero volts across the sense resistor (corresponding to zero current) by sending **CAL:CEXT ZERO**. Send **CAL:DATA** commands as needed (see PAR. 4.3a) until the reading is as close to zero as possible within the limits specified in Table 4-4 for CURRENT ZERO.
28. Replace the  $0V$  d-c reference applied to analog I/O port A2A5J6 pin 11 with a  $+10V \pm 0.1mV$  d-c reference voltage. Set the BOP to maximum positive output current by sending **CAL:CEXT MAX**. Measure the current by reading the voltage across the sense resistor. To adjust, send **CAL:DATA** commands as needed (see PAR. 4.3b) to adjust the BOP output until the DVM reads as close as possible above the nominal full scale value within tolerance specified in Table 4-4 for +FULL SCALE CURRENT.
29. Replace the  $+10V$  d-c reference applied to analog I/O port A2A5J6 pin 11 with a  $0V \pm 0.1mV$  d-c reference voltage. Set the BOP to zero volts across the sense resistor (corresponding to zero current) by sending **CAL:CGA ZERO**. Send **CAL:DATA** commands as needed (see PAR. 4.3a) until the reading is as close to zero as possible within the limits specified in Table 4-4 for CURRENT ZERO.
30. Replace the  $0V$  d-c reference applied to analog I/O port A2A5J6 pin 11 with a  $+10V \pm 0.1mV$  d-c reference voltage. Set the BOP to maximum positive output current by sending **CAL:CGA MAX**. Measure the current by reading the voltage across the sense resistor. To adjust, send **CAL:DATA** commands as needed (see PAR. 4.3a) to adjust the BOP output until the DVM reads as close as close to zero as possible within the limits specified in Table 4-4 for CURRENT ZERO.
31. Send **CAL:ZERO** to prepare for calibration of IOUT\_M\_UNIT (master output) control signal. Connect the DVM to pin 6 (IOUT\_M\_UNIT) referenced to pin 1 (SGND) of the PAR/SER CONTROL IN connector (A2A5J3). Set the BOP to zero output current by sending

**CAL:IOUT ZERO.** Send **CAL:DATA** commands as needed (see PAR. 4.3b) to adjust the BOP output until the DVM reads  $0V \pm 1mV$ .

32. Set the BOP to maximum positive output current by sending **CAL:IOUT MAX.** With the DVM still connected to pin 6 (IOUT\_M\_UNIT) referenced to pin 1 (SGND) of the PAR/SER CONTROL IN connector measure the voltage output using the DVM. Send **CAL:DATA** commands as needed (see PAR. 4.3b) until the DVM reading is  $+10V \pm 1.0mV$ .

33. Send **CAL:ZERO** to prepare for calibration of S\_IN\_PARALLEL (slave input) control signal. Connect a  $0V \pm 0.1mV$  d-c reference to pin 3 (S\_IN\_PARALLEL) referenced to pin 1 (SGND) of the PAR/SER CONTROL IN connector (A2A5J3). Set the BOP to zero output current by sending **CAL:PAR ZERO.** Connect the DVM across the sense resistor to measure the BOP output current and send **CAL:DATA** commands as needed (see PAR. 4.3b) to adjust the BOP output current until the DVM reads as close to zero as possible within tolerance specified in Table 4-4 for CURRENT ZERO.

NOTE: Accuracy of the 10V d-c reference must be  $\pm 0.1mV$  in order for the calibrated unit to meet published specifications.

34. Connect a  $+10V \pm 0.1mV$  d-c reference to pin 3 (S\_IN\_PARALLEL) referenced to pin 1 (SGND) of the PAR/SER CONTROL IN connector (A2A5J3). Set the BOP to maximum positive output current by sending **CAL:PAR MAX.** Measure the output current using the DVM. Send **CAL:DATA** commands as needed (see PAR. 4.3b) until the DVM reading is as specified in Table 4-3 for +FULL SCALE CURRENT.

35. Save the calibration levels by sending **CAL:SAVE 12/21/2003.** The characters at the end are optional and represent the calibration date of the power supply. The date entered in this manner is reported in the \*idn? query.

#### 4.3.2 CALIBRATION OF SERIES- OR PARALLEL-CONNECTED UNITS

Calibrate each individual unit to be used in the multi-unit configuration as a standalone unit (not connected in parallel or series). Calibration of the series-connected or parallel-connected system is not necessary and is not possible.

#### 4.4 CALIBRATION STORAGE

The BOP-G maintains the calibration tables in Flash Memory until a PACK is executed. There are six calibration areas maintained in Flash Memory: Working, Prior, Oldest, Factory, Master, and First.

The calibration can be copied to another area using the **CAL:DUMP?** and **CAL:COPY** command. The syntax is as follows: **CAL:DUMP? [source];:CAL:COPY [destination]**, where [source] and [destination] refer to the areas of Flash memory where calibration data is stored, designated as: WORKing, PRIor, OLDest, FACTory, MASTer, FIRst. Source refers to the calibration area that is to be copied, destination to the area that the calibration will be copied into.

The ability to save to the FACTORY area is prohibited. If a user needs to overwrite the factory calibration, a special firmware needs to be created to provide a special password for this capability. Each customer that requests this capability will be provided a password that the company can specify. It must contain at least one alpha, one numeric and one punctuation character (!@#%&\*) and be at least 6 characters long and not longer than 20 characters in length. All alpha data must be upper case and no control nor space characters are allowed.

The Master calibration should never be overwritten. Factory, Master, and First are set to the same values when the BOP is calibrated at the factory. The Working calibration is the active calibration. Each time a CAL:SAV is executed, the values are saved in the Working (active) area. At the same time, the values previously stored in Working are moved to Prior, and the values previously stored in Prior are moved to Oldest. The values previously stored in Oldest are no longer available. Table 4-5 illustrates calibration storage and the use of the CAL:DUMP? query and CAL:COPY command.

**TABLE 4-5. CALIBRATION STORAGE**

COMMAND	WORKing	PRior	OLDest	FACTory	MASTer	FIRst
1. CAL:SAVE	Cal 1 values			Factory cal.	Master cal.	First cal.
2. CAL:SAVE	Cal 2 values	Cal 1 values		No Change	No Change	No Change
3. CAL:SAVE	Cal 3 values	Cal 2 values	Cal 1 values	No Change	No Change	No Change
4. CAL:SAVE	Cal 4 values	Cal 3 values	Cal 2 values	No Change	No Change	No Change
5. CAL:DUMP? FACTory;:CAL:COPY WORKing	Factory cal.	Cal 4 values	Cal 3 values	No Change	No Change	No Change
6. CAL:DUMP? PRior;:CAL:COPY WORKing	Cal 4 values	Factory cal.	Cal 4 values	No Change	No Change	No Change

## APPENDIX A - SCPI COMMON COMMAND/QUERY DEFINITIONS

### A.1 INTRODUCTION

This appendix defines the SCPI common commands and queries used with the BOP power supply. Common commands and queries are preceded by an asterisk (\*) and are defined and explained in paragraphs A.2 through A.18, arranged in alphabetical order. Table A-1 provides a quick reference of all SCPI common commands and queries used in the Interface Card.

**TABLE A-1. IEEE 488.2 COMMAND/QUERY INDEX**

COMMAND	PAR.	COMMAND	PAR.
*CLS	A.2	*RST	A.11
*ESE, ?	A.3, A.4	*SAV	A.12
*ESR?	A.5	*SRE, ?	A.13, A.14
*IDN?	A.6	*STB?	A.15
*OPC, ?	A.7, A.8	*TRG	A.16
*OPT?	A.9	*TST?	A.17
*RCL	A.10	*WAI	A.18

### A.2 \*CLS — CLEAR STATUS COMMAND

**\*CLS**

Syntax: \*CLS

Description: **Clears status data.** Clears the error queue of the instrument. Forces power supply to “operation complete idle” state. Clears all Event Registers summarized in Status Byte Register without affecting the corresponding Enable Registers: Standard Event Status Register (ESR), Operation Status Event Register, Questionable Status Event Register, and Status Byte Register (STB). Related commands: \*OPC, \*OPC?. (See example, Figure A-1.)

### A.3 \*ESE — STANDARD EVENT STATUS ENABLE COMMAND

**\*ESE**

Syntax: \*ESE <integer> where <integer> = positive whole number: 0 to 255 per Table A-2.  
Default Value: 0

Description: **This command programs the standard Event Status Enable register bits.** The contents function as a mask to determine which events of the Event Status Register (ESR) are allowed to set the ESB (Event Summary Bit) of the Status Byte Register. Enables the Standard events to be summarized in the Status Byte register (1 = set = enable function, 0 = reset = disable function). All of the enabled events of the standard Event Status Enable register are logically ORed to cause ESB (bit 5) of the Status Byte Register to be set (1 = set = enable, 0 = reset = disable). (See example, Figure A-1.)

**TABLE A-2. STANDARD EVENT STATUS ENABLE REGISTER AND STANDARD EVENT STATUS REGISTER BITS**

CONDITION	NU	NU	CME	EXE	DDE	QUE	NU	OPC
BIT	7	6	5	4	3	2	1	0
VALUE	128	64	32	16	8	4	2	1

NU (Not Used)  
 CME Command Error  
 EXE Execution Error  
 DDE Device Dependent Error  
 QUE Query Error  
 OPC Operation Complete

## \*ESE?

### A.4 \*ESE? — STANDARD EVENT STATUS ENABLE QUERY

Syntax: \*ESE?                      Return value: Integer> value per Table A-2.

Description: **Returns the mask stored in the Standard Event Status Enable Register.** Contents of Standard Event Status Enable register (\*ESE) determine which bits of Standard Event Status register (\*ESR) are enabled, allowing them to be summarized in the Status Byte register (\*STB). All of the enabled events of the Standard Event Status Enable Register are logically ORed to cause ESB (bit 5) of the Status Byte Register to be set (1 = set = enable function, 0 = reset = disable function). (See example, Figure A-1.)

## \*ESR?

### A.5 \*ESR? — EVENT STATUS REGISTER QUERY

Syntax: \*ESR?  
Return value: <integer> (Value = contents of Event Status register as defined in Table A-2.)

Description: **Causes the power supply to return the contents of the Standard Event Status register. After it has been read, the register is cleared.** The Standard Event Status register bit configuration is defined in Table A-2 (1 = set, 0 = reset). The error bits listed in Table A-2 are also related to error codes produced during parsing of messages and to errors in the power supply (see PAR. B.134)

- Any 1xx type error sets the Command error bit (5) see.
- Any 2xx type error sets the Execution error bit (4).
- Any 3xx type error sets the Device error bit (3). The Device error bit will be set when Current Error or Voltage Error is detected and the corresponding Status Questionable bit is set (see PAR. B.28).
- Any 4xx type error sets the Query error bit (2).

Related Commands: \*CLS, \*ESE, \*OPC. (See example, Figure A-1.)

## \*IDN?

### A.6 \*IDN? — IDENTIFICATION QUERY

Syntax: \*IDN?  
Return value: Character string

Description: **Identifies the instrument.** This query requests identification. The power supply returns a string which contains the manufacturer name, the model, factory calibration date, serial number and firmware level. The character string contains the following fields separated by commas: <MFR>,<MODEL VOLT-CURR CALDATE>,<SER\_NO.>,<FIRMWARE REV> where <MFR> (manufacturer) = Kepco, <MODEL VOLT-CURR CALDATE> has three subfields: MODEL = BOP1KW, VOLT-CURR = rated voltage and current, and CALDATE = factory calibration date formatted as MM/DD/YYYY (month/day/year). <SER\_NO.> is the 6-digit serial number and <FIRMWARE REV> is the firmware revision. (See example, Figure A-1.)

## \*OPC

### A.7 \*OPC — OPERATION COMPLETE COMMAND

Syntax: \*OPC

Description: **Causes power supply to set status bit 0 (Operation Complete) to “0” indicating the unit is busy. When pending operations are complete this status bit is set to “1.”** This command sets Standard Event Status Register bit 0 (see Table A-2) to “0.” Subsequent \*OPC? commands return “0” until all three microprocessors are idle, indicating that all previous commands have been executed and changes in output level have been completed. When all microprocessors are idle, \*OPC? return “1.” \*OPC? must be preceded by \*OPC to first clear status bit 0, otherwise the \*OPC? will return a “1” that has no meaning. This command does not prevent processing of subsequent commands, but bit 0 will not be set until all pending operations are completed. (1 = set = enable function, 0 = reset = disable function). (See example, Figure A-1.) As an example, the controller sends command(s), then sends \*OPC. If controller then sends \*ESR?, the power supply responds with either a “0” (if the power supply is busy executing the programmed commands), or a “1” (if the previously programmed commands are complete). (See example, Figure A-1.)



# \*OPC?

## A.8 \*OPC? — OPERATION COMPLETE QUERY

Syntax: \*OPC?

Return value: <1 or 0> (ASCII)

0 placed in output queue if power supply has not completed operation after prior \*OPC command.

1 placed in output queue when power supply has completed operation.

Description: **Indicates when pending operations have been completed.** \*OPC command must be sent first to clear status bit 0 (Operation Complete). \*OPC? will return "0" until all pending operations are complete (all previous commands have been executed and changes in output level have been completed) At that time \*OPC? will return "1." Unlike the \*WAI command (see PAR. A.18), subsequent commands are not inhibited while status bit 0 is "0." \*OPC? is intended to be used at the end of a command line so that the application program can monitor the bus for data until it receives the "1" from the power supply Output Queue. (See example, Figure A-1.)

*CLS	Power supply clears status data.
*ESE 60	Power supply enables bits 5, 4, 3 and 2, allowing command error, execution error, device dependent error and query error to set the Event Status Summary bit when an STB command is executed.
*ESE?	Returns 60, (value of the mask) verifying that bits 5, 4, 3 and 2 are enabled.
*ES	Unknown command will set command error (Bit 5).
*ESR?	Returns 33 (bit 5 set), indicating Command Error has occurred since the last time the register was read. Bit 1 indicates operation complete (OPC).
*IDN?	Power supply returns: KEPCO,BOP1KW 36-28 09/30/2001,123456,4.01
*OPC	Allows status bit 0 to be set when pending operations complete.
OUTP ON;:VOLT 21;CURR 3;*WAI;*OPC?	If unit is in voltage mode, sets output voltage to 21V, output current protection limit to 3A. *OPC? will return a 1 indicating the command has been processed by the BOP.
*ESR?	Returns 1, (operation complete, bit 1 = 1).
*ESR?	Returns 0 (event status register cleared by prior *ESR?).
VOLT 15;CURR 5;*OPC?	Sets output voltage to 15V, output current protection limit to 5A, puts "1" on output bus when command operations are complete.
*RST	Power supply reset to power on default state including TRIG:SOUR IMM.
*SRE 40	When ESB or QUES bits are set (Table A-3), the Request for Service bit will be set.
*SRE?	Returns the value of the mask (40).
*STB?	For example, the Power supply responds with 96 (64 + 32) if MSS and the Event Status Byte (Table A-3) summary bit have been set. The power supply returns 00 if no bits have been set.
OUTP ON	Programmed voltage will be applied to output terminals.
VOLT 25	Power supply voltage commanded to 25V.
*WAI	Next command (VOLT:TRIG 12) cannot be executed until VOLT 25 is complete.
TRIG:SOUR BUS	Selects *TRG commands to be used to trigger the unit.
VOLT:TRIG 12	Programs power supply voltage to 12V when *TRG received.
INIT	Trigger event is initialized.
*TRG	Power supply reverts to commanded output voltage of 12V. ** LOAD DISCONNECTED
*TST?	Power supply executes self test and responds with 0 if test completed successfully, with 1 if test failed.

FIGURE A-1. GPIB COMMANDS

# \*OPT?

## A.9 \*OPT? — OPTIONS QUERY

Syntax: \*OPT?  
Returns string determined by power supply model.

Description: **Causes the power supply to return an ASCII string which defines the functionality of the power supply.** The functionality is defined as follows:

STRING DATA	MEANING
CCAL	Support for limit calibrations is present.
RL1	Commands sent over GPIB cause unit to enter remote mode.
MEMM	Computer location commands are supported.
LSTAPL	LIST Apply command is supported.

# \*RCL

## A.10 \*RCL — RECALL COMMAND

Syntax: \*RCL <integer> (1 to 99)

Description: **Restores power supply to previously defined levels of output voltage, output current and triggers.** This command selects one of the 99 power supply memory locations, each of which stores values for output current and output voltage. Executing a \*RCL recalls the stored settings (see \*SAV, PAR. A.12, for details) from the specified location and applies them to the unit. Locations 1 through 15 can also be implemented immediately upon power-up if power-up switch S3-5 is set to on (see Table 2-2 and Figure 2-2).

# \*RST

## A.11 \*RST — RESET COMMAND

Syntax: \*RST

Description: **Resets power supply to the power on default state.** The power supply output set to power-on default state (see PAR. 3.5.5): fixed voltage mode, 0 volts, current protect at minimum (box) value and TRIG:SOUR to IMM. The factory default setting also insures the output is in the off condition. Other commands such as \*CLS are affected by \*RST. The specific commands that are affected and what occurs are explained in PAR. 3.6.3.1.3 and Table 3-7. After sending \*RST it is necessary to send OUT-Put ON for programmed values to appear at the output.

# \*SAV

## A.12 \*SAV — SAVE COMMAND

Syntax: \*SAV <integer> (1 to 99)

Description: **Saves the present state of output voltage and output current to the specified memory location.** This command stores the present state of the power supply to one of 99 memory locations in Flash Memory (see PAR. 3.7.3.6). The following parameters are stored by \*SAV: FUNC:MODE, VOLT:MODE, CURR:MODE, VOLT:PROT, and CURR:PROT. Settings stored are:

- Mode of operation (Voltage, Current or External) FUNC:MODE < >
- Main channel reference type (internal or external) and setting (if internal)  
VOLT:MODE < > or CURR:MODE < >, VOLT < > or CURR < >
- Protection channel reference type (internal or external) and setting (if internal)  
VOLT:PROT:MODE < > or CURR:PROT:MODE < >, VOLT:PROT < > or CURR:PROT < >
- Output status (on or off) OUTP < >

The stored values can be restored by the \*RCL command. See PAR. 3.5.5.2 and Figure 3-6 for special programming considerations. Locations 1 through 15 can also be implemented immediately upon power-up if power-up switch S3-5 is set to on (see Table 2-2 and Figure 2-2).

### A.13 \*SRE — SERVICE REQUEST ENABLE COMMAND

## \*SRE

Syntax: \*SRE<integer> where <integer> = value from 0 - 255 per Table A-3, except bit 6 cannot be programmed.

Description: **Sets the condition of the Service Request Enable register.** The Service Request Enable register determines which events of the Status Byte Register are summed into the MSS (Master Status Summary) and RQS (Request for Service) bits. RQS is the service request bit that is cleared by a serial poll, while MSS is not cleared when read. A “1” (1 = set = enable, 0 = reset = disable) in any Service Request Enable register bit position enables the corresponding Status Byte bit to set the RQS and MSS bits. All the enabled Service Request Enable register bits then are logically ORed to cause Bit 6 of the Status Byte Register (MSS/RQS) to be set. Related Commands: \*SRE?, \*STB?. (See example, Figure A-1.)

TABLE A-3. SERVICE REQUEST ENABLE AND STATUS BYTE REGISTER BITS

CONDITION	OPER	MSS RQS	ESB	MAV	QUES	ERR QUE	LIST RUN	BUSY
BIT	7	6	5	4	3	2	1	0
VALUE	128	64	32	16	8	4	2	1

BUSY Busy  
 LIST RUN List is running  
 OPER Operation Status Summary  
 MSS Master Status Summary  
 RQS Request for Service  
 ESB Event Status Byte summary  
 MAV Message available  
 QUES QUEStionable Status Summary  
 ERR QUE 1 or more errors occurred (see PAR. B.134)

### A.14 \*SRE? — SERVICE REQUEST ENABLE QUERY

## \*SRE?

Syntax: \*SRE? Response: <integer> = value from 0 - 255 per Table A-3.

Description: **Reads the Service Enable Register.** Used to determine which events of the Status Byte Register are programmed to cause the power supply to generate a service request (1 = set = function enabled, 0 = reset = function disabled). Related Commands: \*SRE, \*STB? (See example, Figure A-1.)

### A.15 \*STB? — STATUS BYTE REGISTER QUERY

## \*STB?

Syntax: \*STB? Response: <integer> value from 0 to 255 per Table A-3.

Description: **Reads Status Byte Register without clearing it.** This Query reads the Status Byte Register (bit 6 = MSS) without clearing it (1 = set = function enabled, 0 = reset = function disabled). The register is cleared only when subsequent action clears all set bits. MSS is set when the power supply has one or more reasons for requesting service. (A serial poll also reads the Status Byte Register, except that bit 6 = RQS, not MSS; and RQS will be reset.) Related Commands: \*SRE, \*SRE?. (See example, Figure A-1.)

### A.16 \*TRG — TRIGGER COMMAND

## \*TRG

Syntax: \*TRG

Description: **Triggers the power supply to be commanded to preprogrammed values of output current and voltage.** When the trigger is armed, \*TRG generates a trigger signal if TRIG:SOUR is set to BUS and the WTG bit in Status Operational Condition register (bit 5, Table B-3) is asserted. The trigger is armed by sending a) INIT:CONT ON to continuously arm the trigger and allow subsequent \*TRG commands to generate the trigger signal or b) if INIT:CONT is set to OFF, sending INIT arms the system and allows a \*TRG to generate a single trigger. If \*TRG is received while the trigger is not armed, the trigger is not produced and no error is generated.

The trigger will change the output of the power supply to the output voltage and current levels specified by VOLT:TRIG and CURR:TRIG commands and clear the WTG bit in the Status Operation Condition register. If INIT:CONT 1 (ON) has been issued, the trigger subsystem is immediately rearmed for subsequent triggers, and the WTG bit is again set to 1. \*TRG or GET are both addressed commands (only devices selected as listeners will execute the command). If output is set to OFF, \*TRG is ignored. Related Commands: ABOR, INIT, TRIG, CURR:TRIG, VOLT:TRIG. (See example, Figure A-1.)

# \*TST?

## A.17 \*TST? — SELF TEST QUERY

Syntax: \*TST?                      Returned value: 7 bits coded per Table A-4.

Description: **Power Supply test.** This query causes the power supply to do a self test and provide the controller with pass/fail results. A 0 is returned if the unit passes the test. If the unit fails, a number from 1 through 128 is returned to indicate the cause of the error. The test executes each of the subtests even when any one fails. If any test fails an error code bit is set which is returned to the user. The error codes returned are listed in Table A-4

**TABLE A-4. BUILT-IN TEST ERROR CODES**

TEST ACTIVE		ERROR CODES		MEANING
*tst?	DIAG:TST?	BIT	VALUE	
Yes	Yes		0	Pass (No error)
Yes	Yes	0	1	ROM error
Yes	Yes	1	2	RAM error
Yes	Yes	2	4	FLASH error -- Perform calibration to correct
Yes	Yes	4	16	Analog Communication error
No	Yes	5	32	Loop Back Test error
No	Yes	6	64	Max Voltage Output error
No	Yes	7	128	Min Voltage Output error

## A.18 \*WAI — WAIT-TO-CONTINUE COMMAND

# \*WAI

Syntax: \*WAI                      Response:

Description: **Causes the power supply to wait until all previously issued commands and queries are complete before executing subsequent commands or queries.** This command can be used to guarantee sequential execution of commands and queries. When all pending operations are complete (all previous commands have been executed, changes in output level have been completed), the WAI command is completed and execution of subsequent commands can continue.

## APPENDIX B - SCPI COMMAND/QUERY DEFINITIONS

### B.1 INTRODUCTION

This appendix defines the SCPI subsystem commands and queries used with the BOP power supply. Subsystem commands are defined in PAR. B.3 through B.150, arranged in groups as they appear in the tree diagram, Figure 3-9. Table B-1 provides a quick reference of all SCPI subsystem commands and queries used in the BOP.

**TABLE B-1. SCPI SUBSYSTEM COMMAND/QUERY INDEX**

COMMAND	PAR.	COMMAND	PAR.
ABOR	B.3	[SOUR:]LIST:CURR, ?	B.54, B.55
CAL	B.4	[SOUR:]LIST:CURR:APPL	B.56
INIT[:IMM]	B.5	[SOUR:]LIST:CURR:APPL:SWE, ?	B.57, B.58
INIT:CONT, ?	B.6, B.7	[SOUR:]LIST:POIN?	B.59
MEAS:CURR?	B.8	[SOUR:]LIST:DIV, ?	B.60, B.61
MEAS:MODE	B.9	[SOUR:]LIST:DWEL, ?	B.62, B.63
MEAS:VOLT?	B.10	[SOUR:]LIST:DWEL:POIN?	B.64
MEAS:TRAN?	B.11	[SOUR:]LIST:QUER, ?	B.65, B.66
MEM:UPD	B.12	[SOUR:]LIST:REP	B.67
OUTP[:STAT], ?	B.13, B.14	[SOUR:]LIST:RES?	B.68
OUTP:CONT, ?	B.15, B.16	[SOUR:]LIST:SAMP:CURR	B.69
OUTP:MODE, ?	B.17, B.18	[SOUR:]LIST:SAMP:VOLT	B.70
[SOUR:]CURR, ?	B.19, B.20	[SOUR:]LIST:SAMP?	B.71
[SOUR:]CURR:LIM[:BOTH], ?	B.21, B.22	[SOUR:]LIST:SET:SAMP, ?	B.72, B.73
[SOUR:]CURR:LIM:NEG, ?	B.23, B.24	[SOUR:]LIST:SET:TRIG, ?	B.74, B.75
[SOUR:]CURR:LIM:POS, ?	B.25, B.26	[SOUR:]LIST:SET:WAIT, ?	B.76, B.77
[SOUR:]CURR:MODE, ?	B.27, B.28	[SOUR:]LIST:TRIG:	B.78
[SOUR:]CURR:PROT[:BOTH], ?	B.29, B.30	[SOUR:]LIST:VOLT, ?	B.79, B.80
[SOUR:]CURR:PROT:MODE, ?	B.31, B.32	[SOUR:]LIST:VOLT:APPL	B.81
[SOUR:]CURR:PROT:NEG, ?	B.33, B.34	[SOUR:]LIST:VOLT:APPL:SWE, ?	B.82, B.83
[SOUR:]CURR:PROT:POS, ?	B.35, B.36	[SOUR:]LIST:VOLT:POIN?	B.84
[SOUR:]CURR:PROT:LIM[:BOTH], ?	B.37, B.38	[SOUR:]LIST:WAIT:HIGH	B.85
[SOUR:]CURR:PROT:LIM:NEG, ?	B.39, B.40	[SOUR:]LIST:WAIT:LEDG	B.86
[SOUR:]CURR:PROT:LIM:POS, ?	B.41, B.42	[SOUR:]LIST:WAIT:LOW	B.87
[SOUR:]CURR:TRIG, ?	B.43, B.44	[SOUR:]VOLT, ?	B.88, B.89
[SOUR:]FUNC:MODE, ?	B.45, B.46	[SOUR:]VOLT:LIM[:BOTH], ?	B.90, B.91
[SOUR:]FUNC:MODE:TRIG, ?	B.47, B.48	[SOUR:]VOLT:LIM:NEG, ?	B.92, B.93
[SOUR:]LIST:CLE	B.49	[SOUR:]VOLT:LIM:POS, ?	B.94, B.95
[SOUR:]LIST:COUN, ?	B.50, B.51,	[SOUR:]VOLT:MODE, ?	B.96, B.97
[SOUR:]LIST:COUN:SKIP, ?	B.52, B.53	[SOUR:]VOLT:PROT[:BOTH], ?	B.98, B.99

NOTE: Commands listed above that are followed by ", ?" have a related query.

**TABLE B-1. SCPI SUBSYSTEM COMMAND/QUERY INDEX (CONTINUED)**

COMMAND	PAR.	COMMAND	PAR.
[SOUR:]VOLT:PROT:MODE, ?	B.100, B.101	SYST:COMM:SER:BAUD, ?	B.126, B.127
[SOUR:]VOLT:PROT:NEG, ?	B.102, B.103	SYST:COMM:SER:ECHO, ?	B.128, B.129
[SOUR:]VOLT:PROT:POS, ?	B.104, B.105	SYST:COMM:SER:PACE, ?	B.130, B.131
[SOUR:]VOLT:PROT:LIM[:BOTH], ?	B.106, B.107	SYST:COMM:SER:PROM, ?	B.132, B.133
[SOUR:]VOLT:PROT:LIM:NEG, ?	B.108, B.109	SYST:ERR?	B.134
[SOUR:]VOLT:PROT:LIM:POS, ?	B.110, B.111	SYST:ERR:CODE? ALL?	B.135, B.136
[SOUR:]VOLT:TRIG	B.112, B.113	SYST:KEYB, ?	B.137, B.138
STAT:OPER:COND?	B.114	SYST:PASS:CEN	B.139
STAT:OPER:ENAB, ?	B.115, B.116	SYST:PASS:CDIS	B.140
STAT:OPER[:EVEN]?	B.117	SYST:PASS:NEW	B.141
STAT:PRES	B.118	SYST:PASS:STAT	B.142
STAT:QUES[:EVEN]?	B.119	SYST:REM, ?	B.143, B.144
STAT:QUES:COND?	B.120	SYST:SEC:IMM	B.145
STAT:QUES:ENAB, ?	B.121, B.122	SYST:SET, ?	B.146, B.147
SYST:BEEP	B.124, B.125	SYST:VERS?	B.148
SYST:COMM:GPIB:ADDR, ?	B.124, B.125	TRIG:SOUR, ?	B.149, B.150

NOTE: Commands listed above that are followed by “, ?” have a related query.

## B.2 NUMERICAL VALUES

For all **decimal** values the SCPI data parser of the BOP supports a maximum of eight digits after the decimal point and a maximum of four digits before the decimal point. For example: If volt 10345.2e-1 is processed, the output will become 34.52 volts because the unit only recognizes the first four digits preceding the decimal point. Sending volt 0.0000034567e6 will result in the output being set to 3.45 volts because the unit only recognizes the first eight digits after the decimal point.

The unit can process any number between 6500.9999 and .000001. Any values greater than these are not processed by the device and a “120 - numeric data error” (see Table B-5) is generated. The largest string that can be received or transmitted by the BOP is 253 characters. All numerical data is returned in scientific notation, digits with decimal point and Exponent, e.g., 2.71E1 for 27.1.

The unit also supports keywords of MAXimum and MINimum to set the numeric entry to the most positive and negative allowable values, respectively. For example, If the user has established the volt:limit to be 6, sending the command VOLT MAX causes the output to be set to 6 volts. This syntax can be very useful in the setting of a limit, e.g., VOLT:PROT:LIM MAX sets the positive voltage protection limit to the maximum voltage ( $E_{Omax} + 1\%$ ) and the negative voltage protection limit to  $(-1.01 \times E_{Omax})$ .

## B.3 ABORt COMMAND

## ABOR

Syntax: Short Form: ABOR Long Form: ABORt

Description: **Cancels previously armed trigger, resets WTG.** if the trigger system is armed (INIT:CONT set to OFF and INIT sent), sending ABORt disarms the trigger system so subsequent trigger commands have no effect. If INIT:CONT ON has been programmed, this command has no effect. Related Commands: INIT, \*TRG. (See example, Figure B-1.)

## B.4 CAL COMMANDS AND QUERIES

## CAL

CAL commands and queries are used to perform calibration of the unit via the control interface. These commands must be issued in a specific sequence in order to properly calibrate the unit. To use these commands, refer to Kepco’s website ([www.kepcopower.com/drivers](http://www.kepcopower.com/drivers)) and download the LabWindows/CVI Version 5 driver for BOP or refer to PAR. 4.3.1. This file provides remote calibration capability and uses the following supported commands and queries:

CAL:CEXT command  
 CAL:CGA command  
 CAL:CLIM command  
 CAL:CPR command  
 CAL:CURR[:DATA] command  
 CAL:DATA value command  
 CAL:DPOT command  
 CAL:SAVE command

CAL:STAT command and query  
 CAL:VEXT command  
 CAL:VGA command  
 CAL:VLIM command  
 CAL:VOLT[:DATA] command  
 CAL:VPR command  
 CAL:ZERO command

## B.5 INITiate[:IMMediate] COMMAND

## INIT[:IMM]

Syntax: Short Form: INIT[:IMM] Long Form: INITiate[:IMMediate]

Description: **Enables a single trigger.** This command enables a single trigger. A \*TRG command completes the sequence, however TRIG:SOUR (see PAR. B.149) must be set to BUS. Upon receipt of the \*TRG command, the power supply will return to the commanded values of voltage and current established by the VOLT:TRIG and CURR:TRIG commands. After a \*TRG command has been received, subsequent \*TRG commands have no effect unless preceded by INIT or INIT:CONT ON. Related Commands: \*TRG, TRIG, TRIG:SOUR. (See example, Figure B-1.)

NOTES: 1. The power supply is assumed to be operating in constant voltage mode.  
 2. Examples below are intended only to illustrate command functions. Refer to PAR. for programming techniques to optimize performance.

OUTP ON	Turns the output on.
VOLT 21; CURR 1.5	Power supply output programmed to go to 21V, current limit 1.5A
INIT:CONT ON	Continuous triggers enabled.
INIT:CONT?	Power supply returns "1."
TRIG:SOUR BUS	Prepare unit to wait for *TRG.
VOLT:TRIG 15;CURR:TRIG 3	Power supply output programmed to return to 15V, current limit 3A upon receipt of trigger.
*TRG	Power supply output returns to 15V,current limit 3A.
VOLT 21; CURR 5E-2	Power supply output programmed to go to 21V, current limit 0.05A
MEAS:VOLT?	If actual value of output voltage is 20.99V, power supply returns 2.099E1 within the limits of readback accuracy.
MEAS:CURR?	If actual value of output current is 0.0499A, power supply returns 4.99E-2 within the limits of readback accuracy.
FUNC:MODE CURR	Establishes constant current mode as power supply operating mode.
VOLT 21; CURR 1.1	Power supply programmed to voltage limit 21V, 1.1A.
CURR?	Returns 1.1.
FUNC:MODE VOLT	Establishes constant voltage mode as power supply operating mode.
CURR:TRIG?	Returns 3 (current value established by CURR:TRIG).
VOLT:TRIG?	Returns 15 (voltage value established by VOLT:TRIG).
*TRG	Power supply output returns to 15V, current limit 3A.
INIT:CONT 0	Triggers disabled.
INIT:CONT?	Power supply returns "0."
VOLT 0	Power supply output programmed to go to 0V.
MEAS:VOLT?	Returns 0 within the limits of readback accuracy (measured output voltage).
VOLT?	Returns 0 within the limits of readback accuracy (programmed output voltage).
CURR?	Returns 3 (programmed current).
MEAS:CURR?	Returns 0 within the limits of readback accuracy (measured output current).

FIGURE B-1. PROGRAMMING THE OUTPUT

## B.6 INITiate:CONTInuous COMMAND

## INIT:CONT

Syntax: Short Form: INIT:CONT {ON | OFF} or {1 | 0} (1 = on, 0 = off)  
Long Form: INITiate:CONTInuous {ON | OFF} or {1 | 0} (1 = on, 0 = off)

Description: **INIT:CONT ON enables continuous triggers.; INIT:CONT OFF disables continuous triggers.** If INIT:CONT is OFF, then INIT[:IMM] arms the trigger system for a single trigger. If INIT:CONT is ON, then the trigger system is continuously armed and INIT[:IMM] is redundant. While INIT:CONT is ON, WTG (bit 5 of the Operation Status Condition register (See Table B-3) is always 1 if the TRIG:SOUR is BUS. If TRIG:SOUR is set to EXT, WTG is reset to 0 when the trigger is generated, then set to 1 automatically by the unit. Unlike the BUS trigger source, the transitions in WTG status can be captured by setting WTG (bit 5) in the Status Operation Enabled Register to cause the WTG bit to be set in the Status Operation Event register. (See example, Figure B-1.) Executing \*RST sets the init:cont state to 0 or off and clears the WTG bit in the STATUS OPERATION REGISTER.

## B.7 INITiate:CONTInuous QUERY

## INIT:CONT?

Syntax: Short Form: INIT:CONT? Long Form: INITiate:CONTInuous?  
Return Value: 1 or 0

Description: **Determines whether continuous triggers are enabled or disabled.** Power supply returns value of INIT:CONT flag: "1" = continuous triggers are enabled (INIT:CONT ON); "0" = continuous triggers disabled (INIT:CONT OFF). (See example, Figure B-1.)

## B.8 MEASure[:SCALar]:CURRent[:DC]? QUERY

## MEAS:CURR?

Syntax: Short Form: MEAS[:SCAL]:CURR[:DC]?  
Long Form: MEASure[:SCALar]:CURRent[:DC]?  
Return Value: <num\_value> (digits with decimal point and Exponent)

Description: **Measures actual current.** This query returns the actual value of output current as determined by the programmed value of voltage and current and load conditions. (See example, Figure B-1.)

## B.9 MEASure[:SCALar]:MODE[:DC] COMMAND

## MEAS:MODE

Syntax: Short Form: MEAS[:SCAL]:MODE[:DC] <int\_value 50 or 60 or 125>  
Long Form: MEASure[:SCALar]:MODE[:DC] <int\_value 50 or 60 or 125>

Description: **Determines measurement sampling rate.** Value of 50, 60, or 125 and represents the sampling rate (Hz) for measurements (MEAS:VOLT? and MEAS:CURR?). The meters' LCD display normally uses a 60 Hertz sample rate, creating a sample of 1 cycle in length or 16.6 milliseconds. The 50 Hz sample rate (20 millisecond sample) is used to display the slower graphic selections on the meter display, The 125 Hz sample rate (10 millisecond sample) is used for the three fastest graphic display selections.

## B.10 MEASure[:SCALar]:VOLTage[:DC]? QUERY

## MEAS:VOLT?

Syntax: Short Form: MEAS[:SCAL]:VOLT[:DC]?  
Long Form: MEASure[:SCALar]:VOLTage[:DC]?  
Return Value: <num\_value> (digits with decimal point and Exponent)

Description: **Measures actual voltage.** This query returns the actual value of output voltage (measured at the sense terminals) as determined by the programmed value of voltage and current and load conditions. (See example, Figure B-1.)

## B.11 MEASure[:SCALar]:TRANsient[:DC]? QUERY

## MEAS:TRAN?

Syntax: Short Form: MEAS[:SCAL]:TRAN[:DC]? Long Form: MEASure[:SCALar]:TRANsient[:DC]?  
Returns <exp\_value>,<exp\_value>, . . . <exp\_value>

Description: **Returns measured sample.** Value returned represents either current or voltage depending on previous LIST. Up to eight comma-separated values may be returned. (See Figures B-2 and B-3.)



## B.12 MEMory:UPDate COMMAND

## MEM:UPD

Syntax: Short Form: MEM:UPD {INT | LIM | SER | OUTP}

Long Form: MEMory:UPDate {INTerface | SERial | LIMits | CONTRast | OUTPut}

Description: **Saves selected variables for the next power-up cycle.** MEM:UPD INT saves GPIB address, and all SYST:SET (PAR. B.146) variables. MEM:UPD SER saves the serial communication state, baud rate, pace control and echo information. MEM:UPD LIM saves limits for voltage and current and the maximum allowable protection values for voltage and current. MEM:UPD OUTP saves the power supply on/off state and the mode of operation. Related commands: SYST:COMM:GPIB:ADDR, SYST:LANG, SYST:SET, VOLT:LIM, CURR:LIM, CURR:PROT:LIM, VOLT:PROT:LIM. See PAR. 3.5.5.2 and Figure 3-6 for special programming considerations.

**CAUTION: When using MEM:UPD it is recommended that the unit be tagged with the saved configuration to avoid unexpected behavior upon power-up.**

NOTES: 1. The power supply is assumed to be operating in constant voltage mode.  
2. This example creates a 5-Ampere, 100-millisecond current pulse and performs a current measurement during the last five milliseconds of the pulse.

IIST:CLE	Clear list.
LIST:SET:SAMPLE .0003125	establishes the sample timing. The value was determined by dividing the sample time (0.005S) by the number of samples (16): $(0.005/16 = 0.0003125)$ .
LIST:CURR:APPL LEVEL,.095,5	Creates the initial part of the current pulse. The time duration (0.0950000) establishes where the sample is to begin. It is determined by multiplying the (time per sample) x (number of samples) and subtracting it from the total time of the pulse (100 milliseconds): $[0.1 - (.0003125 \times 16) = .0950000]$
LIST:SAMPLE:CURR 16,5	Creates the sample of the waveform. The output level is 5 amperes and the number of samples is 16.
LIST:SAMPLE?	Returns 60C indicating one sample will be taken after 60 points of a current list (indicated by the C).
LIST:CURR:APPLY LEVEL,.001,0	Creates the end of the current pulse.
LIST:COUNT 1	Sets the number of loops to one. NOTE Count MUST be set to 1 when measuring a sample, otherwise error -100 "command error" will result.
NOTE: The following five commands execute the function:	
FUNC:MODE CURR	Sets unit to constant current mode.
CURR 0	Sets current to 0 Amperes.
VOLT 10	Sets voltage to 10 Volts.
OUTP ON	Sets the output to ON.
CURR:MODE LIST	Causes the list to be executed. Note that the four prior commands ensure that the unit is working in current mode and has its output on before the current pulse is sent.
MEAS:TRAN?	After executing the list, this query returns the measured value of the sample, e.g., 5.0003E0 (5.0003 Amperes).

**FIGURE B-2. USING LIST COMMANDS TO MEASURE SAMPLE AT END OF PULSE**

- NOTES: 1. The power supply is assumed to be operating in constant voltage mode.  
 2. This example creates a 3-Ampere, 100-millisecond current pulse and performs a current measurement during the first five milliseconds of the pulse.

LIST:CLE	Clear list.
LIST:SET:SAMPLE .0003125	Establishes the sample timing. The value was determined by dividing the sample time (0.005S) by the number of samples (16): $(0.005/16 = 0.0003125)$ .
LIST:CURR 0;LIST:DWELL .030	Establishes the list as a current list and sets dwell time for all points at 30 milliseconds.
LIST:SAMPLE:CURR 16,3	Creates the sample of the waveform. The output level is 3 amperes and the number of samples is 16.
LIST:CURR:APPL LEVEL,.095,3	Creates the initial part of the level. It is established by multiplying the time per sample times the number of samples (16) and subtracting it from the total time of the pulse(100 milliseconds): $[0.1 - (.0003125 \times (16))] = .0950000$
LIST:CURR:APPLY LEVEL,.001,0	Creates the end of the current pulse.
LIST:COUNT 1	Sets the number of loops to one. NOTE: Count MUST be set to 1 when measuring a sample, otherwise error -100 "command error" will result.
	NOTE: The following five commands execute the function:
FUNC:MODE CURR	Sets unit to constant current mode.
CURR 0	Sets current to 0 Amperes.
VOLT 10	Sets voltage to 10 Volts.
OUTP ON	Sets the output to ON.
CURR:MODE LIST	Causes the list to be executed. Note that the four prior commands ensure that the unit is working in current mode and has its output on before the current pulse is sent.
MEAS:TRAN?	After executing the list, this query returns the measured value of the sample. For example, assuming the unit output took 5 milliseconds to become 3 amperes, the returned value will be around 1.5 amperes: 1.5003E0 (1.5003 Amperes)

**FIGURE B-3. USING LIST COMMANDS TO MEASURE SAMPLE AT START OF PULSE**

### B.13 OUTPut[:STATe] COMMAND

## OUTP

Syntax: Short Form: OUTP[:STAT] <boolean> Long Form: OUTPut[:STATe] <boolean>  
 <boolean>=(0 or OFF, 1 or ON)

Description: **Enables or disables the power supply output.** The factory default for power-up is: the output is on and analog control is enabled; however note that the factory default for power-up can be changed using the power-up setup switches at the top cover (see PAR. 3.3.2.1)

The behavior of the unit when OUTP OFF is executed is affected by whether the load is passive (resistive) or active (inductive, capacitive, battery or other electronic loads). Refer to PAR. 3.3.6 for details.

NOTE: "-221,;Settings conflict" will be returned if OUTP command is issued with any of the following conditions present:

- 1) OUTP:CONT is in HON or LON mode.
- 2) OUTP:CONT is in HOFF or LOFF mode and the condition is true (logic 1).
- 3) A list is running.

Related Commands: FUNC:MODE, OUTP?, OUTP:CONT

## B.14 OUTPut[:STATe] QUERY

## OUTP?

Syntax: Short Form: OUTP[:STAT]? Long Form: OUTPut[:STATe]?  
Return Value: <int\_value> (0 or 1)

Description: **Indicates whether power supply output is enabled or disabled.** Returns 0 if output disabled, returns 1 if output enabled. Related Commands: OUTP.

## B.15 OUTPut:CONTRol COMMAND

## OUTP:CONT

Syntax: Short Form: OUTP:CONT {HIGH | LOW | STAN | OFF}  
Long Form: OUTPut:CONTRol {HIGH | LOW | STANdby | OFF}

Description: **Controls the operation of the Remote on/off pin 2 of the Trigger port.**

HIGH: when pin 2 is high or open (not connected), output is on (enabled). When 0 volts or short circuit applied to the pin, output is off (disabled).

LOW: when 0 volts or short circuit applied to pin 2, the output is on (enabled), when high or open (not connected) output is off (disabled).

STANDBY - Logic 0 or short-circuit for at least 100 $\mu$ sec on pin 2 causes the output to go off (disabled). Logic 1 or open does not affect the output; an OUTP ON command must be issued to enable the output.

OFF - pin 2 of the Trigger port is disabled and the unit does not respond to signals applied to this pin. This option is required if using only OUTP ON and OUTP OFF commands to control the output.

The pin state is saved by sending MEM:UPD INTerface, otherwise when power is lost the state of the pin will also be lost and the operation of this pin reverts to the setting established by the Reset Power-up settings (see PAR. 3.3.2.1). If the pin state is saved, it will override the setting established by the Reset Power-up Setting (PAR.3.3.2.1).

Note that even though OUTP:CONT OFF may be saved for power-up, the unit will power-up with the output ON if S3-5 and S3-2 are set to 1, and if S3-5 is set to 0, the output state upon power-up will depend on the information stored in one of the 15 locations selected for power-up. Related Commands: OUTP:CONT?, OUTP ON

## B.16 OUTPut:CONT? QUERY

## OUTP:CONT?

Syntax: Short Form: OUTP:CONT? Long Form: OUTPut:CONTRol?  
Return Value: {HIGH | LOW | STANdby | OFF}

Description: **Indicates operation of Remote on/off pin 2 of Trigger Port.** Returns HIGH, LOW STAND or OFF to indicate how Trigger port pin 2 has been configured. (see PAR. B.15 for details).

## B.17 OUTPut:MODE COMMAND

## OUTP:MODE

Syntax: Short Form: OUTP:MODE {ACTIVE | RESISTIVE | BATTERY}  
Long Form: OUTPut:MODE {ACTIVE | RESISTIVE | BATTERY}

Description: **Determines how the unit functions when output is turned off depending on the type of load in use: active, resistive or battery.** See PAR. 3.3.6 for description of ACTIVE, RESISTIVE and BATTERY modes.

## B.18 OUTPut:MODE? QUERY

## OUTP:MODE?

Syntax: Short Form: OUTP:MODE? Long Form: OUTPut:MODE?]  
Return Value: ACTIVE | RESISTIVE | BATTERY

Description: **Indicates whether power supply is configured for ACTIVE, RESISTIVE or BATTERY type loads.** See PAR. 3.3.6 for description of ACTIVE, RESISTIVE and BATTERY modes. Related Commands: OUTP:MODE.

## B.19 [SOURce:]CURRent[:LEVel][:IMMEDIATE][:AMPLitude] COMMAND

## CURR

Syntax: Short Form: [SOUR:]CURR[:LEV][:IMM]:AMP] <exp\_value>  
Long Form: [SOURce:]CURRent[:LEVel][:IMMEDIATE][:AMPLitude] <exp\_value>  
<exp\_value> = digits with decimal point and Exponent, e.g., 2.71E1 for 27.1

Description: **Sets programmed current level at power supply output.** This command programs output current to a specific value; actual output current will depend on load conditions. Any data that exceeds  $I_{MAX}$  causes error message -222 "data out range" to be posted to the error queue. When sent to a unit operating in voltage mode, this command also sets positive and negative protections (CURR:PROT) to the same value. (See example, Figure B-1.)

**B.20 [SOURce:]CURRent[:LEVel][:IMMediate][:AMPlitude] QUERY**

**CURR?**

Syntax: Short Form: [SOUR:]CURR[:LEV][:IMM][:AMP]? MIN, MAX  
 Long Form: [SOURce:]CURRent[:LEVel][:IMMediate][:AMPlitude]? MIN, MAX  
**Return Value:**<exp\_value> = digits with decimal point and Exponent, e.g., 2.71E1 for 27.1

Description: **Returns either the programmed value, maximum value, or minimum value of current.** The CURR? query returns the programmed value of current. Actual output current will depend on load conditions. The CURR?MAX query returns the maximum positive current allowed for a particular model. CURR? MIN returns minimum negative current allowed for power supply (always negative). **Related Commands:** CURR. (See example, Figure B-1.)

**B.21 [SOURce:]CURRent[:LEVel]:LIMit[:BOTH] COMMAND**

**CURR:LIM[:BOTH]**

Syntax: Short Form: [SOUR:]CURR[:LEV]:LIM[:BOTH] <value>  
 Long Form: [SOURce:]CURRent[:LEVel]:LIMit[:BOTH] <value>  
 where <value> is between zero and I<sub>NOM</sub>

Description: Establishes the software limit <value> for output current, i.e., sets the maximum value of output current that the unit will be allowed to source and sink. Requires MEM:UPD (PAR. B.12) to save for power up. See PAR. 3.5.5.2 and Figure 3-6 for special programming considerations. (See Figure B-4)

- NOTES: 1. This example assumes a BOP 36-28G power supply is operating in constant current (CC) mode.  
 2. Examples below are intended only to illustrate command functions. Refer to PAR. for programming techniques to optimize performance.

CURR:LIM?	Returns 28,28 (positive and negative defaults for max current in current mode).
CURR:LIMIT:POS 10;NEG 2	Establishes the maximum positive and negative current values that can be set in current mode.
FUNC:MODE VOLT VOLT 15;CURR 2	SETS POWER SUPPLY IN VOLTAGE MODE. Allows the power supply to provide 15 volts positive with the ability to source or sink up to 2 amperes. The display shows: 15.000 2.000 2.000.
CURR 10	Since the BOP is operating in voltage mode, sets the current capability (current protect) to 10 amperes. The display shows: 15.000 10.000 10.000
CURR:PROT? CURR:PROT:NEG 1 CURR:PROT:LIM:NEG 5	Returns 10,10 Limits the negative current capability to 1 ampere. Prevents CURR:PROT:NEG setting from exceeding 5 amperes
CURR:PROT?	Returns 10,1 (the actual positive (10) and negative (1) protection levels for the current.
	---- Turn BOP power off and then on.
CURR:LIM?	Returns 28,28 the factory default levels (all the above changes have been lost). To save the changed limits for power-up, the user must send MEM:UPD LIM.
CURR:PROT:LIM:POS 28.3;NEG 28	Establishes new max current protect limits (positive 28.3 and negative 28.
CURR 28	Establishes the positive protect to be 28 amperes and the negative protection remains 28 amperes.
CURR:PROT? FUNC:MODE CURR	returns 28,28 Changes the mode of operation of the power supply to current mode.

**FIGURE B-4. SETTING LIMITS**

**B.22 [SOURce:]CURRent[:LEVe]:LIMit[:BOTH]? QUERY****CURR:LIM[:BOTH]?**

Syntax: Short Form: [SOUR:]CURR[:LEV]:LIM[:BOTH]?  
 Long Form: [SOURce:]CURRent[:LEVe]:LIMit[:BOTH]?  
 Returns <value>, <value>

Description: Identifies the positive software limit, followed by the negative software limit value of output current that the unit can source or sink.

**B.23 [SOURce:]CURRent[:LEVe]:LIMit:NEG COMMAND****CURR:LIM:NEG**

Syntax: Short Form: [SOUR:]CURR[:LEV]:LIM:NEG <value>  
 Long Form: [SOURce:]CURRent[:LEVe]:LIMit:NEGative <value>

Description: Establishes the negative software limit <value> for output current, i.e., sets the maximum value of output current that the unit will be allowed to source (quadrant 3, Figure 1-3) or sink (quadrant 2) to the value specified by the user. Requires MEM:UPD (PAR. B.12) to save for power up. See PAR. 3.5.5.2 and Figure 3-6 for special programming considerations.

**B.24 [SOURce:]CURRent[:LEVe]:LIMit:NEG? QUERY****CURR:LIM:NEG?**

Syntax: Short Form: [SOUR:]CURR[:LEV]:LIM:NEG?  
 Long Form: [SOURce:]CURRent[:LEVe]:LIMit:NEGative?  
 Returns <value>

Description: Identifies the negative software limit value of output current that the unit can source (quadrant 3, Figure 1-3) or sink (quadrant 2).

**B.25 [SOURce:]CURRent[:LEVe]:LIMit:POS COMMAND****CURR:LIM:POS**

Syntax: Short Form: [SOUR:]CURR[:LEV]:LIM:POS <value>  
 Long Form: [SOURce:]CURRent[:LEVe]:LIMit:POSitive <value>  
 where <value> is between zero and the rated (nominal) output voltage

Description: Establishes the positive software limit <value> for output current, i.e., sets the maximum value of output current that the unit will be allowed to source (quadrant 1, Figure 1-3) or sink (quadrant 4) to the value specified by the user. Requires MEM:UPD (PAR. B.12) to save for power up. See PAR. 3.5.5.2 and Figure 3-6 for special programming considerations.

**B.26 [SOURce:]CURRent[:LEVe]:LIMit:POS? QUERY****CURR:LIM:POS?**

Syntax: Short Form: [SOUR:]CURR[:LEV]:LIM:POS?  
 Long Form: [SOURce:]CURRent[:LEVe]:LIMit:Positive?  
 Returns <value>

Description: Identifies the positive software limit value of output current that the unit can source (quadrant 1, Figure 1-3) or sink (quadrant 4).

## B.27 [SOURce:]CURRent:MODE COMMAND

## CURR:MODE

Syntax: Short Form: [SOUR:]CURR:MODE (FIX | LIST | TRAN <nn> | EXT | GAIN | PROT | HALT)  
Long Form: [SOURce:]CURRent:MODE (FIXed | LIST | TRANSient <nn> | EXTernal | GAIN | PROTECT  
| HALT)  
nn = <value> = time in seconds for transient (from 0.0005 to 2.0)

Description: **Allows the user to execute or stop a list, to execute a transient or to use an external reference.** The default mode is FIXed: the power supply executes commands normally, and LIST commands can be issued to establish the parameters and sequence of a list. This command affects the *main channel*, whether voltage or current.

When CURR:MODE LIST is issued, a list is executed (See LIST commands and Figure B-5). While the list is being executed, LIST commands are not accepted and will produce a command error.

Issuing CURR:MODE FIX while the list is running will stop the execution of the list and return power supply to settings in effect prior to running the list. If the list runs to completion, the settings of the last step of the list will be in effect.

Issuing CURR:MODE HALT while the list is running will stop the execution of the list at the end of a cycle. The settings of the last step executed will be in effect.

CURR:MODE TRAN nn causes the next CURR: or VOLT: command to produce a transient pulse of nn seconds duration. (Similar to VOLT:MODE TRAN (see PAR. B.96 for examples). If the time nn exceeds 2 seconds, error message -222 "dwell or frequency out range" is posted to the error queue.

CURR:MODE EXT Configures the unit to use an external reference to change the main channel, whether voltage or current (see PAR. 3.4). Identical to VOLT:MODE EXT.

CURR:MODE GAIN Configures the unit to use an external reference to provide a proportional output current.

CURR:MODE PROT - allows main channel (CURR or VOLT) to accept values up to the protection limits of the power supply without generating an error. For example for a BOP 36-28G in voltage mode, after sending CURR:MODE PROT, sending CURR 28.3 would set the protection levels to 28.3 and main channel level to 28.

**Related Commands:** LIST commands. (See example, Figure B-5.)

## B.28 [SOURce:]CURRent:MODE? QUERY

## CURR:MODE?

Syntax: Short Form: [SOUR:]CURR[:LEV]:MODE?  
Long Form: [SOURce:]CURRent[:LEVel]:MODE?  
**Return value:** FIXED, LIST, TRANSIENT, EXTERNAL or GAIN

Description: **Identifies active current mode.** Returns LIST while list is being executed. Returns TRANSIENT after CURR:MODE:TRAN command has been issued, but before CURR: or \*TRG command executes the transient. Returns FIXED while in fixed (default) mode of operation. Returns EXT or GAIN when external reference is to be used to either program output current or provide proportional output current, respectively. **Related Commands:** LIST commands. (Similar to VOLT:MODE?, see Figure B-5.)

## B.29 [SOURce:]CURRent[:LEVel]:PROTECT[:BOTH] COMMAND CURR:PROT[:BOTH]

Syntax: Short Form: [SOUR:]CURR[:LEV]:PROT:BOTH <value>  
Long Form: [SOURce:]CURRent[:LEVel]:PROTECT:BOTH <value>  
where <value> is between minimum (box) value (Figure 1-3) and 1% above rated (nominal) output current.

Description: Establishes both the positive and negative protection limits for current, the maximum current the unit is set up to source and sink; maximum is 1% greater than rated output current.

## B.30 [SOURce:]CURRent[:LEVel]:PROTECT[:BOTH] QUERY CURR:PROT[:BOTH]?

Syntax: Short Form: [SOUR:]CURR[:LEV]:PROT[:BOTH]?  
Long Form: [SOURce:]CURRent[:LEVel]:PROTECT[:BOTH]?  
Returns <value>, <value>

Description: Identifies the protection limits for current (source, sink), the maximum current the unit will source or sink

### **B.31 [SOURce:]CURRent[:LEVel]:PROTeCt:MODE COMMAND      CURR:PROT:MODE**

Syntax:      Short Form: [SOUR:]CURR[:LEV]:PROT:MODE (EXT | FIX | LESS )  
              Long Form: [SOURce:]CURRent[:LEVel]:PROTeCt:MODE (EXTeRnal | FIXed | LESSer )

Description: Determines how current protection limits are controlled.  
FIXED - Allows the limits to be controlled by digital signals from SCPI commands.  
EXTERNAL: Allows both current and voltage limits to be controlled by analog signals applied to the analog port; limits set by SCPI command have no effect (see PAR. 3.4).  
LESSER LIMIT: Allows protect limit to be automatically selected from either 1) the external analog limit CURRent applied to the Analog I/O port or 2) the value set SCPI command). Whichever limit has a lower absolute value (closest to zero) has effect.

### **B.32 [SOURce:]CURRent[:LEVel]:PROTeCt:MODE? QUERY      CURR:PROT:MODE?**

Syntax:      Short Form: [SOUR:]CURR[:LEV]:PROT:MODE?  
              Long Form: [SOURce:]CURRent[:LEVel]:PROTeCt:MODE?  
              Returns FIXED, EXTERNAL or LESS

Description: Identifies how current protection limits are controlled. (See PAR. B.31 for details).

### **B.33 [SOURce:]CURRent[:LEVel]:PROTeCt:NEGative COMMAND      CURR:PROT:NEG**

Syntax:      Short Form: [SOUR:]CURR[:LEV]:PROT:NEG <value>  
              Long Form: [SOURce:]CURRent[:LEVel]:PROTeCt:NEGative <value>  
              where <value> is between minimum (box) value (Figure 1-3) and 1% above rated (nominal) output current.

Description: Establishes the negative protection limit for current, maximum is 1% greater than rated (nominal) output current.

### **B.34 [SOURce:]CURRent[:LEVel]:PROTeCt:NEGative? QUERY      CURR:PROT:NEG?**

Syntax:      Short Form: [SOUR:]CURR[:LEV]:PROT:NEG?  
              Long Form: [SOURce:]CURRent[:LEVel]:PROTeCt:NEGative?  
              Returns <value>

Description: Identifies the negative protection limit for current.

### **B.35 [SOURce:]CURRent[:LEVel]:PROTeCt:POSitive COMMAND      CURR:PROT:POS**

Syntax:      Short Form: [SOUR:]CURR[:LEV]:PROT:POS <value>  
              Long Form: [SOURce:]CURRent[:LEVel]:PROTeCt:POSitive <value>  
              where <value> is between minimum (box) value (Figure 1-3) and 1% above rated (nominal) output current.

Description: Establishes the positive protection limit for current, maximum is 1% greater than rated output current.

### **B.36 [SOURce:]CURRent[:LEVel]:PROTeCt:POSitive? QUERY      CURR:PROT:POS?**

Syntax:      Short Form: [SOUR:]CURR[:LEV]:PROT:POS?  
              Long Form: [SOURce:]CURRent[:LEVel]:PROTeCt:POSitive?  
              Returns <value>

Description: Identifies the positive protection limit for current.

### **B.37 [SOURce:]CURRent[:LEVel]:PROTeCt:LIMit[:BOTH] COMMAND      CURR:PROT:LIM[:BOTH]**

Syntax:      Short Form: [SOUR:]CURR[:LEV]:PROT:LIM[:BOTH] <value>  
              Long Form: [SOURce:]CURRent[:LEVel]:PROTeCt:LIMit[:BOTH] <value>  
              where <value> is between minimum (box) value (Figure 1-3) and 1% above rated (nominal) output current.

Description: Establishes the maximum value possible for both the positive and negative protection limits for current. Requires MEM:UPD (PAR. B.12) to save for power up. See PAR. 3.5.5.2 and Figure 3-6 for special programming considerations.

**B.38 [SOURce:]CURRent[:LEVel]:PROTect:LIMit[:BOTH]? QUERY**  
**CURR:PROT:LIM:[:BOTH]?**

Syntax: Short Form: [SOUR:]CURR[:LEV]:PROT:LIM[:BOTH]?  
Long Form: [SOURce:]CURRent[:LEVel]:PROTect:LIMit[:BOTH]?  
Returns <exp\_value>,<exp\_value>

Description: Identifies the maximum value possible for protection limits for current (positive, negative); maximum is 1% greater than rated output current.

**B.39 [SOURce:]CURRent[:LEVel]:PROTect:LIMit:NEGative COMMAND**  
**CURR:PROT:LIM:NEG**

Syntax: Short Form: [SOUR:]CURR[:LEV]:PROT:LIM:NEG <exp\_value>  
Long Form: [SOURce:]CURRent[:LEVel]:PROTect:LIMit:NEGative <exp\_value>  
where <value> is between minimum (box) value (Figure 1-3) and 1% above rated (nominal) output current.

Description: Establishes the minimum (maximum absolute) value possible for the negative protection limit for current. This may be set up to 1% greater than rated current. Requires MEM:UPD (PAR. B.12) to save for power up. See PAR. 3.5.5.2 and Figure 3-6 for special programming considerations.

**B.40 [SOURce:]CURRent[:LEVel]:PROTect:LIMit:NEGative? QUERY**  
**CURR:PROT:LIM:NEG?**

Syntax: Short Form: [SOUR:]CURR[:LEV]:PROT:LIM:NEG?  
Long Form: [SOURce:]CURRent[:LEVel]:PROTect:LIMit:NEGative?  
Returns: <exp\_value>

Description: Identifies the minimum (maximum absolute) value possible for the negative protection limit for current.

**B.41 [SOURce:]CURRent[:LEVel]:PROTect:LIMit:POSitive COMMAND**  
**CURR:PROT:LIM:POS**

Syntax: Short Form: [SOUR:]CURR[:LEV]:PROT:LIM:POS <exp\_value>  
Long Form: [SOURce:]CURRent[:LEVel]:PROTect:LIMit:POSitive <exp\_value>  
where <value> is between minimum (box) value (Figure 1-3) and 1% above rated (nominal) output current.

Description: Establishes the maximum value possible for the positive protection limit for current. This may be set up to 1% greater than rated current. Requires MEM:UPD (PAR. B.12) to save for power up. See PAR. 3.5.5.2 and Figure 3-6 for special programming considerations.

**B.42 [SOURce:]CURRent[:LEVel]:PROTect:LIMit:POSitive? QUERY**  
**CURR:PROT:LIM:POS?**

Syntax: Short Form: [SOUR:]CURR[:LEV]:PROT:LIM:POS?  
Long Form: [SOURce:]CURRent[:LEVel]:PROTect:LIMit:POSitive?  
Returns: <exp\_value>  
Description: Identifies the maximum value possible for the positive protection limit for current.

**B.43 [SOURce:]CURRent[:LEVel]:TRIGgered[:AMPLitude] COMMAND**  
**CURR:TRIG**

Syntax: Short Form: [SOUR:]CURR[:LEV]:TRIG[:AMP] <exp\_value>  
Long Form: [SOURce:]CURRent[:LEVel]:TRIGgered[:AMPLitude] <exp\_value>  
<exp\_value> = digits with decimal point and Exponent, e.g., 2.71E1 for 27.1

Description: **Programs current value to be transferred to output by \*TRG (trigger) commands.** This command can be used to reset many power supplies to preselected parameters by issuing a single \*TRG command. Actual output current will depend on load conditions. If the value exceeds the maximum for the model being programmed, error message -222, "Data out of range" is posted in output queue. **Related Commands:** CURR, \*TRG, TRIG



**B.44 [SOURce:]CURRent[:LEVel]:TRIGgered[:AMPlitude]? QUERY CURR:TRIG?**

Syntax: Short Form: [SOUR:]CURR[:LEV]:TRIG[:AMP]?  
Long Form: [SOURce:]CURRent[:LEVel]:TRIGgered[:AMPlitude]?  
**Return Value:** <exp\_value> = digits with decimal point and Exponent, e.g., 2.71E1 for 27.1

Description: **Returns the current value established by CURR:TRIG command.**

**B.45 [SOURce:]FUNCtion:MODE COMMAND FUNC:MODE**

Syntax: Short Form: FUNC:MODE {VOLT | CURR | EXT}  
Long Form: [SOURce:]FUNCtion:MODE {VOLT | CURR | EXTernal}

Description: **Establishes the operating mode of the power supply.** VOLT = Constant Voltage mode (CV). CURR = Constant Current mode (CC). EXT = External. FUNC:MODE VOLT commands power supply to Voltage mode, FUNC:MODE CURR commands power supply to Current mode. Commanded mode establishes parameters (voltage or current) monitored for error conditions. Actual mode depends upon load conditions. When commanded to Voltage mode, if load conditions cause the power supply to try to exceed the current limit, the unit will flag an error condition. When commanded to Current mode, if load conditions cause the power supply to try to exceed the voltage limit, the unit will flag an error condition.

**B.46 [SOURce:]FUNCtion:MODE? QUERY FUNC:MODE?**

Syntax: Short Form: FUNC:MODE? Long Form: [SOURce:]FUNCtion:MODE?  
**Return value:** 0 (voltage mode) or 1 (current mode)

Description: **Returns the operating mode of the power supply.** 0 = Voltage mode. 1 = Current mode.

**B.47 [SOURce:]FUNCtion:MODE:TRIGger COMMAND FUNC:MODE:TRIG**

Syntax: Short Form: FUNC:MODE:TRIG {VOLT | CURR}  
Long Form: [SOURce:]FUNCtion:MODE:TRIGger {VOLT | CURR}

Description: **Establishes the operating mode of the power supply when a TRIGger command is sent.** VOLT = Constant Voltage mode (CV). CURR = Constant Current mode (CC). FUNC:MODE:TRIG VOLT commands power supply to Voltage mode when a TRIGger command is sent, FUNC:MODE:TRIG CURR commands power supply to Current mode when a TRIGger command is sent.

**B.48 [SOURce:]FUNCtion:MODE:TRIGger? QUERY FUNC:MODE:TRIG?**

Syntax: Short Form: FUNC:MODE:TRIG? Long Form: [SOURce:]FUNCtion:MODE:TRIGger?  
**Return value:** 0 = voltage mode or 1 = current mode

Description: **Returns the operating mode which the power supply will enter when a trigger command is sent.** VOLT = Constant Voltage mode (CV). CURR = Constant Current mode (CC).

**B.49 [SOURce:]LIST:CLEar COMMAND LIST:CLE**

Syntax: Short Form: LIST:CLE Long Form: LIST:CLEar>

Description: **Clears all list entries by setting all pointers to 0.** Releases control of the Output Off flag at EXT PROTECT PORT, pins 5 and 6 (see Table 2-5), from the programmed list. Related Commands: All LIST commands (See example, Figure B-5.)

**B.50 [SOURce:]LIST:COUNt COMMAND LIST:COUN**

Syntax: Short Form: LIST:COUN<int\_value 0 to 255> Long Form: LIST:COUNt> <int\_value 0 to 255>

Description: **Establishes how many times the list is executed.** Allows user to establish how many times the list is executed. For LIST:COUN 0, the unit will execute the sequence indefinitely until a VOLT:MODE FIXED, command is received. (See example, Figure B-5.)

**B.51 [SOURce:]LIST:COUNt? QUERY LIST:COUN?**

Syntax: Short Form: LIST:COUNt? Long Form: LIST:COUNt?  
Return Value: <int\_value>

Description: **Identifies how many times the list will be executed.** Returns value set by LIST:COUN command. (See example, Figure B-5.)

NOTES: Examples below are intended only to illustrate command functions. Refer to PAR. for programming techniques to optimize performance.

LIST:CLEAR	Initializes the list process.
LIST:RES?	Returns 0.000093,0.034000,nnnn (where nnnn = total number of points available).
LIST:VOLT:POINTS?	Returns 0.
LIST:VOLT:POINTS? MAX	Returns 5900.
LIST:VOLT:APPLY SINE,15,10	Causes the BOP to generate points for 15Hz sine wave, 10V p-p.
LIST:VOLT:POIN?	Returns 480 - indicating the unit used 480 points for the sine wave.
LIST:VOLT:POIN? MAX	Returns 3933 - indicating up to 3933 points can be used.
LIST:DWEL:POIN?	Returns 480 - indicating 480 points have been assigned dwell times.
LIST:DWEL?	Returns 1.38e-4 indicating the unit used 138 microseconds per division (automatically selected as the best possible dwell for the waveform).
FUNC:MODE VOLT	Initializes the power supply mode to be voltage.
LIST:CLEAR	Initializes the list processor to add entries, clears main channel (LIST:CURRE or LIST:VOLT) and LIST:DWEL data tables (Table B-2).
LIST:VOLT -20,-18,-16,-14,-12,-10,-8,-6,-4,-2,0	Starting at location 0 (-20), up to location 10 (0), fills the list with 11 data points.
LIST:VOLT:POIN?	Returns 11. Indicates that 11 data points have been entered, and location 11 is the next location to be filled (for the 12th data point).

NOTE: See PAR. B.2 for format and accuracy of all numerical data returned.

LIST:QUERY?	Returns 0 (pointer cleared by LIST:CLEAR).
LIST:VOLT?	Returns -20,-18,-16,-14,-12,-10,-8,-6,-4,-2,0 (the contents of locations 0 through 10). (See PAR. B.2 for format and accuracy of numerical data.)
LIST:VOLT 2,4,6,8,10,12,14,16,18,20	Adds 10 points to the list (location 11 through 20). List now has 21 points.
LIST:VOLT:POIN?	Returns 21 (the next location to be filled by LIST:VOLT).
LIST:COUNT 100	Specifies that when VOLT:MODE LIST is issued, the user-determined sequence will be executed 100 times. (21 steps in the list will be executed 100 times)
CURR 1;VOLT -20	initializes the BOP output
OUTPUT ON	Turns the output on (BOP now provides -20 volts)
LIST:DWELL .010	Sets the time duration for location 0 to be 0.010 second (Since dwell times for the rest of the locations in the list are not entered before running the list, the dwell time will be 0.010 second for all locations.

FIGURE B-5. USING LIST COMMANDS AND QUERIES (SHEET 1 OF 2)

## B.52 [SOURCE:]LIST:COUNT:SKIP COMMAND

## LIST:COUNT:SKIP

Syntax: Short Form: LIST:COUNT:SKIP nn Long Form: LIST:COUNT:SKIP nn  
nn = <int\_value 0 to 255>

Description: **Allows beginning steps of list-generated waveform to be run once, then ignored.**

When a list is to be repeated using LIST:COUNT, this command allows the user to skip the first nn steps once the full set has been executed. After the first iteration (which executes all steps), the first nn steps are skipped. The LIST:COUNT:SKIP command allows the user to precondition a list-generated waveform by setting unique conditions at the beginning that are not repeated for the rest of the repetitions. LIST:CLEAR sets nn to 0. Related Commands: LIST:COUNT, LIST:COUNT:SKIP?, LIST:CLEAR. (See example, Figure B-5.)

.VOLT:MODE LIST	Executes the list. For 240 milliseconds the BOP outputs a staircase triangle wave from -20V to +20V and back down to -20V. This staircase will have a uniform spacing between voltage changes of 10 milliseconds and will repeat 100 times.
VOLT?	Returns +20 (the last step in the list set the unit to +20V).
LIST:COUNT?	Returns 100.
LIST:COUNT 10	Determines that the list will be repeated 10 times when executed.
LIST:COUNT?	Returns 10.
VOLT:MODE LIST	Initiates execution of the list. The unit outputs a sawtooth waveform that increases from -20V to +20V and repeats 10 times. There is an abrupt change from +20V to -20V each time the list transitions from location 20 to location 0.
VOLT?	Returns 20, (the last step in the list set the unit to 20V).
LIST:DWELL.01,.01,.01,.01,.01,.01,.01,.01,.01	Enters dwell time of 0.01 seconds in locations 1 through 9.
LIST:DWELL .03	Enters dwell time of 0.03 second in location 10.
VOLT:MODE LIST	the list is not executed, the unit returns error -221,Settings Error indicating the lists are not balanced.
LIST:DWELL:POINTS?	Returns 11 to indicate the dwell list has 11 entries
LIST:VOLT:POINTS?	Returns 21 to indicate the voltage list has 21 entries.
LIST:DWELL .01,.01,.01,.01,.01,.01,.01,.01,.01,.01	Dwell times are entered in locations 11 through 20.
DWELL:POINTS?	Returns 21 indicating there are now 21 step dwell times on the list.
LIST:QUER?	Returns 0 indicating list queries will start from location 0
LIST:QUER 9	Causes list queries to start at location 9
LIST:DWEL?	Returns 01,.03,.01,.01,.01,.01,.01,.01,.01,.01,.01 (the dwell times for locations 9 through 20).
LIST COUNT 0	List will repeat indefinitely.
VOLT:MODE LIST	The list is executed. Stair case wave now consists of 21 steps of .01 seconds except for the 0V step (location 10) which outputs 0V for 0.03 second.
LIST:DWEL?	Returns error -221,Settings Error because a LIST command cannot be executed while the LIST is still being executed.
VOLT:MODE FIX	Stops execution of the list
LIST:VOLT:APPLY SINE,60,20	Adds a 60Hz, 20V p-p sine wave to the current waveform
VOLT:MODE:LIST	Unit outputs the staircase and then the sine wave.
*RST	Unit stops generating the waveform.

FIGURE B-5. USING LIST COMMANDS AND QUERIES (SHEET 2 OF 2)

**B.53 [SOURCE:]LIST:COUNT:SKIP? QUERY**

**LIST:COUN:SKIP?**

Syntax: Short Form: LIST:COUN:SKIP? Long Form: LIST:COUNT:SKIP?  
Return Value: <int\_value>

Description: **Identifies how many steps will skipped the first time the list is executed.** Returns value set by LIST:COUN:SKIP command. (See example, Figure B-5.)

**B.54 [SOURCE:]LIST:CURRENT COMMAND**

**LIST:CURRE**

Syntax: Short Form: LIST:CURRE <exp\_value>, <exp\_value>, . . . (to max of 5900 data points for global dwell time)  
Long Form: LIST:CURRENT <exp\_value>, <exp\_value>, . . . (to max of 5900 data points for global dwell time)  
<exp\_value> = digits with decimal point and Exponent, e.g., 2.71E1 for 27.1

Description: **Adds the current value (in Amps) to list.** This command sequentially adds LIST:CURRENT values to the main channel List Data Table locations illustrated in Table B-2. Starting location is indicated by LIST:CURRE:POIN? The maximum number of entries is 2950,3933 or 5900. Since the input buffer of the BOP has a limit of 253 characters, multiple commands are necessary to complete the full 3933 entries of the list. If LIST:VOLT has any entries, an error message: -221,"Settings conflict" is posted in the error queue. Related Commands: LIST:CURRE:POIN?. (See example, Figure B-5.).

**TABLE B-2. LIST DATA TABLE**

Location (DSEQ)	0	1	2	3	4	5	6	7	8	9	10	11	12	13	14	15	16	17	.....	5900
Main Channel (commanded mode) LIST:CURRent or LIST:VOLTage																			.....	
LIST:DWELI																			.....	

**B.55 [SOURce:]LIST:CURRent? QUERY**

**LIST:CURR?**

Syntax: Short Form: LIST:CURR? Long Form: LIST:CURRent?  
Return Value: <value1>, <value2>, . . . to <value16>

Description: **Identifies the parameters (main channel) entered for the list.** Starting at location established by LIST:QUERY, returns comma-separated list of up to 16 values indicating the main channel parameters entered. i.e., the contents of main channel locations of Table B-2. Related Commands: LIST: CURR, LIST:QUERY. If LIST:VOLT has any entries, an error message: -221,"Settings conflict" is posted in the error queue. (See example, Figure B-5.)

**B.56 [SOURce:]LIST:CURR:APPLy COMMAND**

**LIST:CURR:APPL**

Syntax: Short Form: LIST:CURR:APPL <type>,<value1>,<value2>[,<value3>]  
Long Form: LIST:CURRent:APPLy <type>,<value1>,<value2>[,<value3>]  
Where <type> is {SQUARE | RAMP+ | RAMP- | TRIANGLE | SINE | LEVEL}  
<value1> is frequency in Hz; for LEVEL <value1> is period, duration in Seconds  
<value2> is p-p amplitude (or amplitude (offset) for LEVEL) in Amperes  
<value3> is offset (optional, default is 0, not applicable to LEVEL) in Amperes

Description: **Causes the unit to add a series of points to both the list:curr array and the list:dwel array to make either a level or a waveform of one of five types.** Refer to table 3-6 for a description of the waveform types. The waveform type specified is generated at the frequency specified with a peak-to-peak amplitude centered on zero. If the optional offset value is specified, the center of the generated series of points is moved off zero. The apply generator takes into account the soft limits for the current channel and insures the generated array does not exceed the unit's capabilities.

**B.57 [SOURce:]LIST:CURRent:APPLy:SWEep COMMAND**

**LIST:CURR:APPL:SWE**

Syntax: Short Form: LIST:CURR:APPL:SWE <value1>,<value2>  
Long Form: LIST:CURRent:APPLy:SWEep <value1>,<value2>  
Where <value1> is start angle. Valid from 0 to 359.99 degrees.  
<value2> is stop angle. Valid from 0.01 to 360.00 degrees

Description: **Allows the user to provide a starting angle for either triangle and sine waveforms and an optional stop angle.** If the stop angle is not supplied, the unit defaults to 360 degrees. This command should be placed at the beginning of the waveform program to be applicable to all sine and triangle waveform segments.

**B.58 [SOURce:]LIST:CURRent:APPLy:SWEep? QUERY**

**LIST:CURR:APPL:SWE?**

Syntax: Short Form: LIST:CURR:APPL:SWE? Long Form: LIST:CURRent:APPLy:SWEep?  
Return Value: <value1>, <value2>(0.01 to 360)

Description: **Returns start <value1> and stop <value2> angle in degrees for either triangle and sine waveforms.**

**B.59 [SOURce:]LIST:CURRent:POINts? QUERY**

**LIST:CURR:POIN?**

Syntax: Short Form: LIST:CURR:POIN? Long Form: LIST:CURRent:POINts?  
Return Value: <n> where n = number of points

Description: **Identifies the total number of points present in a list and the next location to be filled by LIST:CURR command.** The LIST:CURR pointer is initially at 0 via LIST:CLE. For each data point entered by a LIST:CURR command the list pointer is incremented. If LIST:CURR:POIN? returns 5, the LIST:CURR pointer is at 5 indicating there are 6 data points comprising the list. If LIST:VOLT has any entries, an error message: -221,"Settings conflict" is posted in the error queue. Related Commands: LIST:CURR. (See example, Figure B-5.)

## B.60 [SOURCE:]LIST:DIVider COMMAND

## LIST:DIV

Syntax: Short Form: LIST:DIV <value> 1 to 255 Long Form: LIST:DIVider <value> 1 to 255

Description: **Sets the list clock divider to a value from 1 to 255, effectively increasing the actual dwell time programmed by LIST:DWEL by the factor programmed by LIST:DIV.** This command divides dwell times greater than 1 millisecond by the divider. For example, LIST:DIV 10 causes LIST:DWEL 0.01, normally a 10 millisecond dwell time to actually become 100 milliseconds ( $0.01/10 = 0.1$ ). Similarly, LIST:DIV 100 changes the a 10 millisecond time to 1 second ( $0.01/100 = 1$ ). LIST:CLE sets the divider to 1. LIST:APPLY SINE 0.0099 or lower automatically sets the divider to 10. This command affects dwell times greater than 1 milliseconds so it is applied to any waveform with a frequency set to 20 Hz or less. Related Commands: LIST:DWEL, LIST:DWEL?. (See example, Figure B-6.)

## B.61 [SOURCE:]LIST:DIVider? QUERY

## LIST:DIV?

Syntax: Short Form: LIST:DIV? Long Form: LIST:DIVider?  
Return Value: <value>

Description: **Returns the list clock divider value (1 to 255).** This value is the factor by which LIST:DWEL times are divided, altering the programmed LIST:DWEL time (See PAR. B.60. Related Commands: LIST:DWEL, LIST:QUERY. (See example, Figure B-6.)

## B.62 [SOURCE:]LIST:DWELI COMMAND

## LIST:DWEL

Syntax: Short Form: LIST:DWEL <value> (0.000093 to 0.034),<value>,<value>, . . . to maximum of 5900 values.  
Long Form: LIST:DWELI <value> (0.000093 to 0.034),<value>,<value>, . . . to maximum of 5900 values.

Description: **Determines how long the main channel parameters will be active.** Sets time value (from 0.000093 to 0.034) in seconds for List:Dwell locations illustrated in Table B-2. These locations are associated with the corresponding main channel locations illustrated in Table B-2. The main channel is determined by FUNC:MODE, either current (FUNC:MODE CURR) or voltage (FUNC:MODE VOLT) If LIST:DWEL is entered for only location 0, that time duration will apply to all steps when either VOLT:MODE LIST or CURR:MODE LIST is executed. Related Commands: VOLT:MODE, FUNC:MODE, LIST:CURR, LIST:VOLT, LIST:DWEL?. (See example, Figure B-5.)

## B.63 [SOURCE:]LIST:DWELI? QUERY

## LIST:DWEL?

Syntax: Short Form: LIST:DWEL? Long Form: LIST:DWELI?  
Return Value: <value>

Description: **Identifies the dwell times entered for the list.** Starting at location established by LIST:QUERY, returns comma-separated list of up to 16 values indicating the dwell time parameters entered. i.e., the contents of LIST:DWEL locations of Table B-2. Related Commands: LIST: DWEL, LIST:QUERY. (See example, Figure B-5.)

## B.64 [SOURCE:]LIST:DWELI:POINts? QUERY

## LIST:DWEL:POIN?

Syntax: Short Form: LIST:DWEL:POIN? Long Form: LIST:DWELI:POINts?  
Return Value: <value> (0 to 5900)

Description: **Identifies the number of locations for which time values have been entered and the next location to be filled by a LIST:DWEL command.** If LIST:DWEL:POIN? returns 6, dwell times have been entered for locations 0 through 5 and location 6 is the next to be filled by a LIST:DWEL command. LIST:DWEL, LIST:DWEL:POIN. (See example, Figure B-5.)

## B.65 [SOURCE:]LIST:QUERY COMMAND

## LIST:QUER

Syntax: Short Form: LIST:QUER <int\_value>  
Long Form: LIST:QUERY <int\_value>  
int\_value = <n> where n = first location to be queried.

Description: **Determines first location to be queried by LIST:VOLT?, LIST:CURR? or LIST:DWEL? queries.** Related Commands: LIST:VOLT?, LIST:CURR?, LIST:DWEL?. LIST:QUERY?. (See example, Figure B-5.)

## B.66 [SOURCE:]LIST:QUERY? QUERY

## LIST:QUER?

Syntax: Short Form: LIST:QUER? Long Form: LIST:QUERY?  
Return Value: <int\_value>

Description: **Identifies first location to be queried by LIST:VOLT?, LIST:CURR?, LIST:DWEL? queries.**  
Related Commands: LIST:QUER, LIST:CURR?, LIST:DWEL?. LIST:QUER?. (See example, Figure B-5.)

## B.67 [SOURCE:]LIST:REPeat COMMAND

## LIST:REP

Syntax: Short Form: LIST:REP <int\_value1>,<int\_value2>,<array>  
Long Form: LIST:REPeat <int\_value1>,<int\_value2>,<array>  
where <int\_value1> is start point to be copied  
<int\_value2> is end point to be copied  
<array> is a series of comma separated values representing the new  
programmed current (Amps) for current list, or programmed voltage (Volts) for voltage list.

Description: **Copies points from existing list using the same dwell times, but different output settings.** Copies the contents of the dwell entries in the list from the start point to the end point and adds them to the end of the list. The setting value for each copied point is defined by the value in the array. This process is repeated until either a) an invalid programmed current or voltage is found, b) the all entries in the array have been copied or c) the list is full.

This command must be preceded by LIST:CURR or LIST:VOLT command and the starting and end point values must be valid, otherwise a -221 "Settings conflict" error results. The entries on the dwell list must match the values in the current or voltage list, otherwise a -226 "Not Same Length" error results. (See Figures B-7 and B-8.)

## B.68 [SOURCE:]LIST:RESolution? QUERY

## LIST:RES?

Syntax: Short Form: LIST:RES? Long Form: LIST:RESolution?  
Return Value: <value1>,<value2>,<value3>  
(where <value1> and <value2> = clock period, <value3> = number of points to be used)

Description: **Identifies whether resolution is set to minimum (3933) or maximum (5900) and indicates the clock period.** The resolution (3933 or 5900) determines the maximum number of points that will be used for the waveform. <value1> and <value2> indicate the boundaries of acceptable dwell times: e.g., if LIST:RES? returns either 0.000093,0.034000,3933 or 0.034000,0.000093,5900 dwell times faster than 93 microseconds and slower than 34 milliseconds will not be accepted.

## B.69 [SOURCE:]LIST:SAMPle:CURRent COMMAND

## LIST:SAMP:CURR

Syntax: Short Form: LIST:SAMP:CURR average,value  
Long Form: LIST:SAMPle:CURRent average,value  
where:  
<average> = number of measurements = integer: 2, 4, 8, 16, 32, 64, 128 or 256  
<value> = programmed current (Amps) for current list, or programmed voltage (Volts) for voltage list.

Description: **Samples output current.** <Value> is either programmed current in Amperes, or programmed voltage in Volts. <Average> can only be 2, 4, 8, 16, 32, 64, 128 or 256. Entering a number other than those permitted results in the average being set to the next lowest permitted number. The actual number of points added to the list is <average>. The samples are taken within the window established by <average>. The timing of the first sample is not exact. The sample duration must be established by the LIST:SET:SAMP command, otherwise a -221 "Settings conflict" error will result

This command must be preceded by LIST:CURR, LIST:VOLT or LIST:SET:SAMPLE command, otherwise a -221 "Settings conflict" error will result. The entries on the dwell list must match the values on the current or voltage list, otherwise a -226 "Not Same Length" error will result. Only eight samples may be taken in a list. If more than eight LIST:SAMP:CURR or LIST:SAMP:VOLT commands are included in the list, a -223 "Too Much data" error results. Also, note that each sample uses one of the points in the waveform table; if the total number of points in the waveform exceeds 3933, -223 "Too Much data" error results. (See Figures B-7 and B-8.)

## B.70 [SOURCE:]LIST:SAMPle:VOLTage COMMAND

## LIST:SAMP:VOLT

Syntax: Short Form: LIST:SAMP:VOLT average,value  
Long Form: LIST:SAMPle:VOLTage average,value  
where:  
average = number of measurements = integer: 2,4,8,16,32,64,128 or 256  
value = programmed current (Amps) for current list, or programmed voltage (Volts) for voltage list.

Description: **Samples output voltage.** <Value> is either programmed current in Amperes, or programmed voltage in Volts. <Average> can only be 2, 4, 8, 16, 32, 64, 128 or 256. Entering a number other than those permitted results in the average being set to the next lowest permitted number. The actual number of points added to the list is <average>. The samples are taken within the window established by <average>. The timing of the first sample is not exact. The sample duration must be established by the LIST:SET:SAMP command, otherwise a -221 "Settings conflict" error will result

This command must be preceded by LIST:CURR, LIST:VOLT or LIST:SET:SAMPLE command, otherwise a -221 "Settings conflict" error will result. The entries on the dwell list must match the values on the current or voltage list, otherwise a -226 "Not Same Length" error will result. Only eight samples may be taken in a list. If more than eight LIST:SAMP:CURR or LIST:SAMP:VOLT commands are included in the list, a -223 "Too Much data" error results. Also, note that each sample uses one of the points in the waveform table; if the total number of points in the waveform exceeds 3933, -223 "Too Much data" error results. (See Figures B-7 and B-8.)

## B.71 [SOURCE:]LIST:SAMPle? QUERY

## LIST:SAMP?

Syntax: Short Form: LIST:SAMP?  
Long Form: LIST:SAMPle?  
Returns:<INT\_VALUE>,<INT\_VALUE>....<INT\_VALUE>[V|C]

Description: **Returns a comma-separated list of numbers representing points, followed by V or C.** The point listings are determined by the settings of LIST:SAMP:CURR and LIST:SAMP:VOLT commands. The sample(s) occur after the points indicated. The type of list is indicated by V (Voltage) or C (Current). (See Figures B-7 and B-8.)

## B.72 [SOURCE:]LIST:SET:SAMPle COMMAND

## LIST:SET:SAMP

Syntax: Short Form: LIST:SET:SAMP value  
Long Form: LIST:SET:SAMPle value  
where value = sample pulse duration, between 0.00025 and 0.034 (seconds)

Description: **Establishes sample pulse duration.** This command must be used when measuring a sample, but must only be issued once, otherwise a -100 "command error: will result. (See Figures B-7 and B-8.)

## B.73 [SOURCE:]LIST:SET:SAMPle? QUERY

## LIST:SET:SAMP?

Syntax: Short Form: LIST:SET:SAMP? Long Form: LIST:SET:SAMPle?  
Returns: <exp\_value>

Description: **Returns sample pulse duration.** Returns sample pulse duration set by LIST:SET:SAMP command, between 0.00025 and 0.034 second. If sample pulse duration has not been set, error 100- "command error" results.

## B.74 [SOURCE:]LIST:SET:TRIGger COMMAND

## LIST:SET:TRIG

Syntax: Short Form: LIST:SET:TRIG <time>,<transistor>  
Long Form: LIST:SET:TRIGger <time>,<transistor>  
<time> = 0.00025 to 0.034 (Seconds)  
<transistor> = ON or OFF

Description: **Establishes output trigger pulse-width.** Used to set the pulse-width at a) the BOP output and b) a trigger provided by the BOP to trigger an external device. The Output Off flag at EXT PROTECT PORT, pins 5 and 6 (see Table 2-5) represents the trigger pulse timing instead of output on/off status until LIST:CLE is issued. See Figure B-8 for example. The pulse width, between 0.00025 to 0.034 (Seconds) is established by <time>. When <transistor> = ON, the transistor across EXT PROTECT PORT pins 5 and 6 is on (conducting) while pulse is active. When <transistor> = OFF, the transistor across EXT PROTECT PORT pins 5 and 6 is off while pulse is active.

**B.75 [SOURce:]LIST:SET:TRIGger? QUERY****LIST:SET:TRIG?**

Syntax: Short Form: LIST:SET:TRIG? Long Form: LIST:SET:TRIGger?  
Returns <value> = trigger pulse-width between 0.00025 and 0.034 second

Description: **Returns trigger pulse-width.** If trigger pulse duration has not been set, error 100- "command error" results.

**B.76 [SOURce:]LIST:SET:WAIT COMMAND****LIST:SET:WAIT**

Syntax: Short Form: LIST:SET:WAIT value  
Long Form: LIST:SET:WAIT value  
where:  
<value> = time-out for a wait command between .00025 and .034 Second

Description: **Establishes the time-out for a wait command.** If this command is not sent, the time out period will be 0 indicating an infinite wait time. (See Figures B-7 and B-8.)

**B.77 [SOURce:]LIST:SET:WAIT? QUERY****LIST:SET:WAIT?**

Syntax: Short Form: LIST:SET:WAIT? Long Form: LIST:SET:WAIT?  
Returns <value> = time-out for a wait command between 0.00025 and 0.033 Second

Description: Returns the time-out for a wait command. Returns 0 if LIST:SET:WAIT not sent, indicating infinite wait time.

**B.78 [SOURce:]LIST:TRIGger COMMAND****LIST:TRIG**

Syntax: Short Form: LIST:TRIG <value>  
Long Form: LIST:TRIGger <value>  
where:  
<value> = programmed current (Amps) for current list, or programmed voltage (Volts) for voltage list.

Description: **Similar to LIST:VOLT or LIST:CURR, except also allows Output Off flag of External Protection Port to be used to trigger an external device.** In addition to setting the output to the <value> specified (for duration established by LIST:SET:TRIG), causes the Output Off flag transistor (EXT\_E, pin 5, and EXT\_C, pin 6, of the External Protection port) to be set to the state (on or off) for the duration set by the LIST:SET:TRIG command.

If the trigger duration is not established by the LIST:SET:TRIG command, a -221 "Settings conflict" error results. This command must be preceded by LIST:CURR or LIST:VOLT command, otherwise a -221 "Settings conflict" error results. The entries on the dwell list must match the values on the current or voltage list, otherwise a -226 "Lists Not Same Length" error results. (See Figure B-8.)

**B.79 [SOURce:]LIST:VOLTage COMMAND****LIST:VOLT**

Short Form: LIST:VOLT[:LEV] <exp\_value>, <exp\_value>, . . . (to max of 5900 data points)  
Long Form: LIST:VOLTage[:LEVel] <exp\_value>, <exp\_value>, . . . (to max of 5900 data points)  
<exp\_value> = digits with decimal point and Exponent, e.g., 2.71E1 for 27.1

Description: **Adds the voltage value (in Amps) to list.** This command sequentially adds LIST:VOLTage values to the main channel List Data Table locations illustrated in Table B-2. LIST:CLE sets starting location to 0. Next location indicated by LIST:VOLT:POIN? The maximum number of entries is 2950, 3933, or 5900. Since the input buffer of the BOP has a limit of 253 characters, multiple commands are necessary to complete the full 5900 entries of the list. If LIST:CURR has any entries, an error message: -221,"Settings conflict" is posted in the error queue. Related Commands: LIST:VOLT:POIN?, FUNC:MODE, LIST:CLE, \*RST. (See example, Figure B-5.)

**B.80 [SOURce:]LIST:VOLTage? QUERY****LIST:VOLT?**

Syntax: Short Form: LIST:VOLT? Long Form: LIST:VOLTage?  
Return Value: <value1>, <value2>, . . . to <value16>

Description: **Identifies the parameters (main channel) entered for the list.** Starting at location established by LIST:QUERY, returns comma-separated list of up to 16 values indicating the main channel parameters entered. i.e., the contents of the main channel locations of Table B-2. Related Commands: LIST:VOLT, LIST:QUERY. If LIST:CURR has any entries, an error message: -221,"Settings conflict" is posted in the error queue. (See example, Figure B-5.)



### SIMPLE STAIRCASE SAWTOOTH WAVEFORM EXAMPLE

*RST	Resets power supply to the default state.
CURR 1	Sets programmed current to 1A.
LIST:CLE	Clears all list entries by setting all pointers to 0.
LIST:VOLT -5,-4,-3,-2, -1,0,1,2,3,4,5	Create 10 steps that increases from -5V to +5V.
LIST:DWEL 0.01	Set the dwell time for each step to 10 milliseconds.
LIST:COUN 10	Determines that the list will be repeated 10 times when executed.
OUTP ON	Turns the BOP output on.
VOLT:MODE LIST	Initiates execution of the first list.

Upon sending VOLT:MODE LIST, the unit outputs a sawtooth waveform that increases from -5V to +5V and repeats 10 times. Each step is 1V with a dwell time of 0.01 second. There is an abrupt change from +5V to -5V each time the list transitions from the last step to the first step of the waveform. After the waveform repeats 10 times, the list stops running and the unit output will be +5V (the last step in the list). The total list running time is equal to:

$$10 \text{ (from LIST COUN)} \times 11 \text{ (total number of list steps)} \times 0.01 \text{ second (dwell time of each step)} \\ = 0.11 \text{ seconds}$$

LIST:DIV 100	Sets the list clock to divide by 100, increasing the dwell time by a factor of 100.
--------------	---

VOLT:MODE LIST  
Initiates the execution of the second list. This sawtooth waveform is the similar to the first list (see above), except that the dwell time is 1 second ( 0.01 x 100) and the total time is 110 seconds (10 x 11 x 1 second, where 1 second is the new dwell time).

### SIMPLE STAIRCASE TRIANGLE WAVEFORM EXAMPLE

*RST	Resets power supply to the default state
CURR 1	Sets programmed current to 1A
LIST:CLE	Clears all list entries by setting all pointers to 0.
LIST:DIV 100	Sets the list clock to divide by 100, increasing the dwell time by a factor of 100.
LIST:VOLT 0,1,2,3,4,5,6,7,8,9,10	Create 11 steps that increase from 0V to +10V.
LIST:VOLT 9,8,7,6,5,4,3,2,1,0	Create 10 steps that decrease from +9V to 0V. The 21-step list forms a triangle stair waveform that first increases from 0V to +10V and then decreases to 0V.
LIST:DWEL 0.02	Sets the dwell time for each step to 2 seconds because LIST:DIV is set to 100.
LIST:COUN 10	Determines that the list will be repeated 10 times when executed.
OUTP ON	Turns the BOP output on
VOLT:MODE LIST	Initiates execution of the list.

The unit outputs a triangle stair waveform, that increases from 0V to +10V and then decreases to 0V. The waveform repeats 10 times. Each step is 1V with a dwell time of 2 seconds. The waveform stays at 0V for 4 seconds because for each repetition, the last step of the decreasing list and the first step of the increasing list are both 2 seconds at 0V. When the list stops running, the output will be 0V (the last step of the list). The total list running time is equal to:

$$10 \text{ (from LIST COUN)} \times 21 \text{ (total number of list steps)} \times 2 \text{ seconds (dwell time of each step)} = 420 \text{ seconds}$$

To eliminate the first step and make the waveform times even, when the list stops running, add the following command between OUTP ON and VOLT:MODE LIST above.

LIST:COUN:SKIP 1	Skip first step (0V level) after the first iteration
------------------	--

Upon sending VOLT:MODE LIST, the unit outputs a triangle stair waveform, that is identical to the original, except that the first step (0V) is only executed for the first iteration. After 10 repetitions the list stops running and the output is 0V. The total list running time is equal to:

$$10 \text{ (from LIST COUN)} \times 20 \text{ (total number of repeated list steps)} \times 2 \text{ seconds (dwell time of each step)} = 400 \text{ seconds} \\ + 2 \text{ seconds (dwell time of first step, run only once)} = 402 \text{ seconds.}$$

**FIGURE B-6. USING LIST COMMANDS FOR SAWTOOTH AND TRIANGLE WAVEFORMS**

- NOTES: 1. The power supply is assumed to be operating in constant voltage mode.
2. The WAIT commands provide a method to synchronize multiple instruments to a common control pulse. This example assumes BOP and a number of switching DVMs are connected to a Unit Under Test (UUT). The DVMs are programmed to wait 1 millisecond after a high pulse is received from the host computer, then take a few measurements. The same high pulse is applied to the Trigger Input (pin 3 of the BOP Trigger Port); the negative-going edge of this pulse will cause the BOP to increment the output to the next level. Thus, each time the host computer issues a positive pulse, the BOP increments and the DVMs take measurements on the trailing (negative-going) edge of the positive pulse. The positive pulse must be greater than 4 milliseconds in width for this example to operate correctly.
3. The explanation below shows how each step of the list functions once the list is entered and VOLT:MODE LIST (the last step) is executed.

LIST:CLE	Clears the list.
LIST:VOLT:APPLY LEVEL,.001,0	Establishes the list as a voltage list, output set to 0V.
LIST:DWELL:POINTS?	Returns 10. (Levels below 3 milliseconds use 10 points.)
LIST:WAIT:HIGH 0	Maintains output at 0V, waits for Input trigger high before proceeding.
	--- Host computer issues high pulse. Trigger input goes high and List proceeds to next point.
LIST:WAIT:LOW 0	Maintains output at 0V, waits for Input Trigger low before proceeding.
	--- Input Trigger goes low at trailing (negative-going) edge of pulse from host commuter and List proceeds to next point. One millisecond after pulse issued, DVM takes measurements.
LIST:WAIT:HIGH 1.1	Sets output to 1.1V (next point in waveform), waits for Input Trigger high before proceeding.
	--- Host computer issues another high pulse. Trigger input goes high and List proceeds to next point.
LIST:WAIT:LOW 1.1	Maintains output at 1.1V, waits for Input Trigger low before proceeding.
	--- Input Trigger goes low at trailing (negative-going) edge of pulse from host computer and List proceeds to next point. One millisecond after pulse issued, DVM takes measurements.
LIST:DWELL:POINTS?	Returns the current point location (6). (Used for list:repeat.)
LIST:WAIT:HIGH 2.2	Sets output to 2.2V (next point in waveform), waits for Input Trigger high before proceeding.
	--- Host computer issues another high pulse. Trigger input goes high and List proceeds to next point.
LIST:WAIT:LOW 2.2	Maintains output at 2.2V, waits for Input Trigger low before proceeding.
	--- Input Trigger goes low at trailing (negative-going) edge of pulse from host computer and List proceeds to next point. One millisecond after pulse issued, DVM takes measurements.
LIST:DWELL:POINTS?	Returns the current point location (16).
LIST:REPEAT 6,7,3.3,4.4,5.5,6.6,7.7	Repeats step 6 and 7 (list:wait:high and list:wait:low), except each pair is set to the voltage specified in the array. This adds 10 points to the list and sets the output values of each pair to be 3.3V, 4.4V, 5.5V, 6.6V, 7.7V.
LIST:COUNT 2	Implements the waveform through two loops of the data.
LIST:DWELL:POINTS?	Returns 10.
LIST:COUNT:SKIP 10	Bypass the first step in the repeated points.
CURR 5::OUTP ON	Set output on, output current to 5A.
	--- Ensure Input Trigger is low.
VOLT:MODE LIST	Executes the above list. At each low transition of the trigger line the BOP increases its output voltage in 1.1 volt increments. The time period for each increment is controlled not by the internal clock of the BOP but rather the high-to-low edge of the pulse from the host computer. The use of LIST:WAIT:HIGH followed by LIST:WAIT:LOW ensures the BOP waits for a high-to-low edge transition on the trigger input before increasing the output.

**FIGURE B-7. USING LIST:WAIT COMMANDS TO CONTROL GENERATION OF A WAVEFORM MEASURED BY MULTIPLE EXTERNAL DEVICES USING A SINGLE EXTERNAL PULSE**

- NOTES:
1. The power supply is assumed to be operating in constant voltage mode.
  2. This example assumes a BOP and a DVM is connected to a Unit Under Test (UUT). The DVM is connected to EXT\_E/ EXT\_C (pins 5/6 of the BOP External Protection port). When the BOP outputs a low EXT\_E/ EXT\_C, The DVM takes a series of measurements and places its wait line low. The DVM Wait line is connected to the Trigger Input (pin 3 of the of the BOP. When the Trigger Input goes high (indicating the DVM has completed its measurements) the BOP will advance to the next point. For this example it is assumed that the DVM will complete its measurement within 25 milliseconds to 75 milliseconds unless a problem is encountered. A “dead man” timer is implemented that allows up to 99 milliseconds for the measurement to complete before automatically proceeding to the next point, thereby preventing hang-ups due to a measurement problem.
  3. The explanation below shows how each step of the list functions once the list is entered and VOLT:MODE LIST (the last step) is executed.

LIST:CLE	Clear list.
LIST:SET:WAIT .0333	Set wait time to max allowed value (33 milliseconds).
LIST:SET:TRIGGER .001,ON	Set trigger pulse width to 1 millisecond. Transistor across pins 5 and 6 of External Protection Port is now set off.
LIST:VOLT:APPLY LEVEL,.001,10	Create first point (10V).
LIST:DWELL:POINTS?	Returns 10.
LIST:TRIGGER 10	Maintains output at 10V, generates a 1 millisecond 0V trigger pulse applied to DVM, causing DVM to make measurement.
	Trigger input low while DVM makes measurement.
LIST:WAIT:HIGH 10	Wait for DVM to complete measurement for 33 milliseconds. Proceed to next step if trigger input goes high (meaning the measurement is complete) or 33 milliseconds elapsed, whichever comes first.
	Trigger input low while DVM makes measurement.
LIST:WAIT:HIGH 10	Wait for DVM to complete measurement for another 33 milliseconds. Proceed to next step if trigger input goes high (meaning the measurement is complete) or 33 milliseconds elapsed, whichever comes first
	Trigger input low while makes measurement.
LIST:WAIT:HIGH 10	Wait for DVM complete measurement for another 33 milliseconds (these three steps allow a maximum wait time of 99 milliseconds. Proceed to next step if trigger input goes high (meaning the measurement is complete) or 33 milliseconds elapsed, whichever comes first.
LIST:REPEAT 10,13,20,30,40,50,60,70,80,90	Repeats steps 10 through 13 (from list:apply level to the third list:wait:high 10) for the other 8 voltages (20, 30, . . . 90).
LIST:COUNT 10	Repeat sequence ten times.
CURR 2;:OUTP ON	Establishes BOP output current of 2A.
VOLT:MODE LIST	Executes the above list. A level is applied to the BOP output. One 1 millisecond later the transistor at EXT_E and EXT_C (pins 5 and 6 of the External Protection Port) conducts, providing a low to the DVM. The DVM immediately places the BOP trigger input low. The BOP waits for the trigger input to go high, then outputs the next level in the list. If the trigger input never goes high, the three wait statements will maintain the level for 33 milliseconds each. After 99 milliseconds (three wait statements) has expired, the new voltage level will be provided at the output. In this example, the pulse must be less than 1 millisecond. but at least 50 microseconds long to insure proper operation of the program.

**FIGURE B-8. USING LIST:WAIT COMMANDS TO ALLOW AN EXTERNAL DEVICE TIME TO FUNCTION WHILE IMPOSING A MAXIMUM WAIT TIME**

## B.81 [SOURce:]LIST:VOLT:APPLy COMMAND

## LIST:VOLT:APPL

Syntax: Short Form: LIST:VOLT:APPL <type>,<value1>,<value2>[,<value3>]  
Long Form: LIST:VOLTage:APPLy <type>,<value1>,<value2>[,<value3>]  
Where <type> is {SQUARE | RAMP+ | RAMP- | TRIANGLE | SINE | LEVEL}  
<value1> is frequency in Hz; for LEVEL <value1> is period, duration in Seconds  
<value2> is p-p amplitude (or amplitude (offset) for level) in Volts  
<value3> is offset (optional, default is 0, not applicable to level) in Volts

Description: **Causes the unit to add a series of points to both the list:volt array and the list:dwel array to make either a level or a waveform of one of five types.** Refer to table 3-6 for a description of the waveform types. The waveform type specified is generated at the frequency specified with a peak-to-peak amplitude centered on zero. If the optional offset value is specified, the center of the generated series of points is moved off zero. The apply generator takes into account the soft limits for the voltage channel and insures the generated array does not exceed the unit's capabilities.

## B.82 [SOURce:]LIST:VOLTage:APPLy:SWEep COMMAND

## LIST:VOLT:APPL:SWE

Syntax: Short Form: LIST:VOLT:APPL:SWE <>,  
Long Form: LIST:VOLTage:APPLy:SWEep <value1>,<value2>  
Where <value1> is start angle. Valid from 0 to 359.99 degrees.  
<value2> is stop angle. Valid from 0.01 to 360.00 degrees

Description: **Allows the user to provide a starting angle for either triangle and sine waveforms and an optional stop angle.** If the stop angle is not supplied, the unit defaults to 360 degrees. This command should be placed at the beginning of the waveform program to be applicable to all sine and triangle waveform segments.

## B.83 [SOURce:]LIST:VOLTage:APPLy:SWEep? QUERY

## LIST:VOLT:APPL:SWE?

Syntax: Short Form: LIST:VOLT:APPL:SWE? Long Form: LIST:VOLTage:APPLy:SWEep?  
Return Value: <value1>,<value2>(0.01 to 360)

Description: **Returns start <value1> and stop <value2> angle in degrees for either triangle and sine waveforms.**

## B.84 [SOURce:]LIST:VOLTage:POINts? QUERY

## LIST:VOLT:POIN?

Syntax: Short Form: LIST:VOLT:POIN? Long Form: LIST:VOLTage:POINts?  
Return Value: <n> where n = number of points used

Description: **Identifies the total number of points in a list and the next location to be filled by LIST:VOLT command.** The LIST:VOLT pointer is initially at 0 via LIST:CLE. For each data point entered by a LIST:VOLT command the list pointer is incremented. If LIST:VOLT:POIN? returns 5, the LIST:VOLT pointer is at 5 indicating there are 5 data points comprising the list (locations 0 though 4) and location 5 is the next to be filled. If LIST:CURR has any entries, an error message: -221,"Settings conflict" is posted in the error queue. Related Commands: LIST:VOLT. (See example, Figure B-5.)

## B.85 [SOURCE:]LIST:WAIT:HIGH COMMAND

## LIST:WAIT:HIGH

Syntax: Short Form: LIST:WAIT:HIGH value  
Long Form: LIST:WAIT:HIGH value  
where:  
<value> = programmed current (Amps) for current list, or programmed voltage (Volts) for voltage list.

Description: **Waits for the trigger input to go high before advancing to next step.** When the command is executed the output is immediately set to the <value>. Pins 1 (GND) and 3 of the Trigger Port are used as the input trigger. If the trigger input is high (TTL logic 1 or open circuit) and a wait time has been established by LIST:SET:WAIT, the step is immediately skipped. If the trigger input is low (TTL logic 0 or short-circuit), the unit will proceed to the next step when either a) the trigger input goes high or b) the wait time expires (non-zero wait values only), whichever comes first. If the wait time is 0, the unit must wait until the trigger input goes high before proceeding to the next step.

In all cases, the trigger input must be high or low for at least 0.4 milliseconds to be considered stable. This 0.4 millisecond delay provides a noise filter to insure only a level causes the output change.

This command must be preceded by LIST:CURR or LIST:VOLT command, otherwise a -221 "Settings Conflict" error results. The entries of the dwell list must match the values in the current or voltage list, otherwise a -226 "Lists Not Same Length" error results. (See Figures B-7 and B-8.)

## B.86 [SOURCE:]LIST:WAIT:LEDG COMMAND

## LIST:WAIT:LEDG

Syntax: Short Form: LIST:WAIT:LEDG value  
Long Form: LIST:WAIT:LEDGe value  
where:  
<value> = programmed current (Amps) for current list, or programmed voltage (Volts) for voltage list.

Description: **Waits for the leading edge of the trigger input to go low before proceeding to the next step.** If the trigger input is already low, the signal must go high then low for the leading edge to be accepted. When the command is executed the output is immediately set to the <value>. Pins 1 (GND) and 3 of the Trigger Port are used as the input trigger. If the trigger input goes from high to low (TTL logic 0 or short-circuit) and a wait time has been established by LIST:SET:WAIT, the unit will proceed to the next step when either a) the trigger input goes low or b) the wait time expires (non-zero wait values only), whichever comes first. If the wait time is 0, the unit must wait until the trigger input goes from high to low before proceeding to the next step.

This command must be preceded by LIST:CURR or LIST:VOLT command, otherwise a -221 "Settings Conflict" error results. The entries of the dwell list must match the values in the current or voltage list, otherwise a -226 "Lists Not Same Length" error results. (See Figure B-9.)

## B.87 [SOURCE:]LIST:WAIT:LOW COMMAND

## LIST:WAIT:LOW

Syntax: Short Form: LIST:WAIT:LOW value  
Long Form: LIST:WAIT:LOW value  
where:  
<value> = programmed current (Amps) for current list, or programmed voltage (Volts) for voltage list.

Description: **Waits for the trigger input to go low before advancing to next step.** When the command is executed the output is immediately set to the <value>. Pins 1 (GND) and 3 of the Trigger Port are used as the input trigger. If the trigger input is low (TTL logic 0 or short-circuit) and a wait time has been established by LIST:SET:WAIT, the step is immediately skipped. If the trigger input is high (TTL logic 1 or open circuit), the unit will proceed to the next step when either a) the trigger input goes low or b) the wait time expires (non-zero wait values only), whichever comes first. If the wait time is 0, the unit must wait until the trigger input goes low before proceeding to the next step.

In all cases, the trigger input must be high or low for at least 2 microseconds to be considered stable. This 2 microsecond delay provides a noise filter to insure only a level causes the output change.

This command must be preceded by LIST:CURR or LIST:VOLT command, otherwise a -221 "Settings Conflict" error results. The entries of the dwell list must match the values in the current or voltage list, otherwise a -236 "Lists Unbalanced" error results. (See Figures B-7 and B-8.)

- NOTES:
1. The power supply is assumed to be operating in constant voltage mode.
  2. The WAIT commands provide a method to synchronize multiple instruments to a common control pulse. This example assumes BOP and a number of switching DVMs are connected to a Unit Under Test (UUT). The DVMs are programmed to wait 1 millisecond after a low-going edge is received from the host computer, then take a few measurements. The same low-going edge is applied to the Trigger Input (pin 3 of the BOP Trigger Port); the negative-going edge of this pulse will cause the BOP to increment the output to the next level. Thus, each time the host computer issues a positive pulse, the BOP increments and the DVMs take measurements on the trailing (negative-going) edge of the positive pulse. The positive pulse can be very short (less than 2 microseconds) with this functionality.
  3. The explanation below shows how each step of the list functions once the list is entered and VOLT:MODE LIST (the last step) is executed.

LIST:CLE	Clears the list.
LIST:VOLT:APPLY LEVEL,.001,0	Establishes the list as a voltage list, output set to 0V.
LIST:DWELL:POINTS?	Returns 10. (Wait of 33 milliseconds uses 10 points.)
LIST:WAIT:LEDGE 0	Maintains output at 0V, waits for Input trigger to have a high to low edge before proceeding.
--- Host computer issues high pulse. Input Trigger goes low at trailing (negative-going) edge of pulse from host commuter and List proceeds to next point. One millisecond after pulse issued, DVM takes measurements.	
LIST:DWELL:POINTS?	Returns the current point location (3). (Used for list:repeat.)
LIST:REPEAT 9,10,1.1,2.2,3.3,4.4,5.5,6.6,7.7	Repeats step 9 and 10 (list:volt:apply lev and list:wait:ledge), except each pair is set to the voltage specified in the array. This adds 14 points to the list and sets the output values of each pair to be 1.1V, 2.2V, 3.3V, 4.4V, 5.5V, 6.6V and 7.7V.
LIST:COUNT 2	Implements the waveform through two loops of the data.
CURR 5::OUTP ON	Set output on, output current to 5A.
VOLT:MODE LIST	Executes the above list. At each high-to-low transition of the Trigger Port input, the BOP increases its output voltage in 1.1 volt increments. The duration of each increment is not controlled by the internal clock of the BOP, but instead by the high-to-low edge of the pulse from the host computer.

**FIGURE B-9. USING LIST:WAIT COMMANDS TO CONTROL GENERATION OF A WAVEFORM MEASURED BY MULTIPLE EXTERNAL DEVICES USING THE LOW-GOING LEADING EDGE OF AN EXTERNAL PULSE**

### **B.88 [SOURce:]VOLTage[:LEVel][:IMMediate][:AMPlitude] COMMAND**

## **VOLT**

Syntax: Short Form: [SOUR:]VOLT[:LEV][:IMM][:AMP] <exp\_value>  
 Long Form: [SOURce:]VOLTage[:LEVel][:IMMediate][:AMPlitude] <exp\_value>  
 <exp\_value> = digits with decimal point and Exponent, e.g., 2.71E1 for 27.1

Description: **Sets programmed voltage level at power supply output.** This command programs output voltage to a specific value; actual output voltage will depend on load conditions. If the value exceeds the maximum for the model being programmed, error message -222, "Data out of range" is posted in output queue. When sent to a unit operating in current mode, this command also sets positive and negative protections (VOLT:PROT) to the same value. (See example, Figure B-1.)

**B.89 [SOURce:]VOLTage[:LEVel][:IMMEDIATE][:AMPLitude]? QUERY****VOLT?**

Syntax: Short Form: [SOUR:]VOLT[:LEV][:IMM][:AMP]? {MIN | MAX}  
 Long Form: [SOURce:]VOLTage[:LEVel][:IMMEDIATE][:AMPLitude]? {MIN | MAX}

Description: **Identifies programmed voltage, maximum allowable voltage, or minimum voltage.** The VOLT? query returns the programmed value of voltage. Actual output voltage will depend on load conditions. The VOLT?MAX query returns the maximum voltage allowed for a particular model. VOLT? MIN returns minimum voltage allowed for power supply (always negative). **Related Commands:** VOLT. (See example, Figure B-1.)

**B.90 [SOURce:]VOLTage[:LEVel]:LIMit[:BOTH] COMMAND****VOLT:LIM[:BOTH]**

Syntax: Short Form: [SOUR:]VOLT[:LEV]:LIM[:BOTH] <value>  
 Long Form: [SOURce:]VOLTage[:LEVel]:LIMit[:BOTH] <value>  
 where <value> is between zero and rated (nominal) output voltage

Description: Establishes the software limit <value> for output voltage, i.e., sets the maximum value of positive or negative output voltage that the unit will be allowed to produce. Requires MEM:UPD (PAR. B.12) to save for power up. See PAR. 3.5.5.2 and Figure 3-6 for special programming considerations.

**B.91 [SOURce:]VOLTage[:LEVel]:LIMit[:BOTH]? QUERY****VOLT:LIM[:BOTH]?**

Syntax: Short Form: [SOUR:]VOLT[:LEV]:LIM[:BOTH]?  
 Long Form: [SOURce:]VOLTage[:LEVel]:LIMit[:BOTH]?  
 Returns <value>

Description: Identifies the software limit value for both positive and negative output voltage specified by the user.

**B.92 [SOURce:]VOLTage[:LEVel]:LIMit:NEGative COMMAND****VOLT:LIM:NEG**

Syntax: Short Form: [SOUR:]VOLT[:LEV]:LIM:NEG <value>  
 Long Form: [SOURce:]VOLTage[:LEVel]:LIMit:NEGative <value>  
 where <value> is between zero and rated (nominal) output voltage

Description: Establishes the software limit <value> for negative output voltage, i.e., sets the maximum value of negative output voltage that the unit will be allowed to produce. Requires MEM:UPD (PAR. B.12) to save for power up. See PAR. 3.5.5.2 and Figure 3-6 for special programming considerations.

**B.93 [SOURce:]VOLTage[:LEVel]:LIMit:NEGative? QUERY****VOLT:LIM:NEG?**

Syntax: Short Form: [SOUR:]VOLT[:LEV]:LIM:NEG? <value>  
 Long Form: [SOURce:]VOLTage[:LEVel]:LIMit:NEGative? <value>

Description: Identifies the software limit value for negative output voltage specified by the user.

**B.94 [SOURce:]VOLTage[:LEVel]:LIMit:POSitive COMMAND****VOLT:LIM:POS**

Syntax: Short Form: [SOUR:]VOLT[:LEV]:LIM:POS <value>  
 Long Form: [SOURce:]VOLTage[:LEVel]:LIMit:POSitive <value>  
 where <value> is between zero and rated (nominal) output voltage

Description: Establishes the software limit <value> for positive output voltage, i.e., sets the maximum value of positive output voltage that the unit will be allowed to produce. Requires MEM:UPD (PAR. B.12) to save for power up. See PAR. 3.5.5.2 and Figure 3-6 for special programming considerations.

**B.95 [SOURce:]VOLTage[:LEVel]:LIMit:POSitive? QUERY****VOLT:LIM:POS?**

Syntax: Short Form: [SOUR:]VOLT[:LEV]:LIM:POS? <value>  
 Long Form: [SOURce:]VOLTage[:LEVel]:LIMit:POSitive? <value>

Description: Identifies the software limit value for positive output voltage specified by the user.

## B.96 [SOURce:]VOLTage:MODE COMMAND

## VOLT:MODE

Syntax: Short Form: [SOUR:]VOLT:MODE (FIX | LIST | TRAN <nn> | EXT | GAIN | PROT | HALT)  
Long Form: [SOURce:]VOLTage:MODE (FIXed | LIST | TRANSient <nn> | EXTernal | GAIN | PROTect | HALT)  
nn = <value> = time in seconds for transient (from 0.0005 to 2)

Description: **Allows the user to execute or stop a list, to execute a transient, or to use an external reference.** The default mode is FIXed: the power supply executes commands normally, and LIST commands can be issued to establish the parameters and sequence of a list. This command affects the *main channel*, whether voltage or current.

When VOLT:MODE LIST is issued, a list is executed (See LIST commands and Figure B-5). While the list is being executed, LIST commands are not accepted and will produce a command error.

Issuing VOLT:MODE FIX while the list is running will stop the execution of the list and return power supply to settings in effect prior to running the list. If the list runs to completion, the settings of the last step of the list will be in effect.

Issuing VOLT:MODE HALT while the list is running will stop the execution of the list at the end of a cycle. The settings of the last step executed will be in effect.

VOLT:MODE TRAN nn causes the next VOLT: or CURR: command to produce a transient pulse of nn seconds duration, after which the voltage returns to original value. E.g., VOLT:25 sets the output to 25 volts, and VOLT:MODE TRAN 0.1 primes the unit for a transient of 0.1 seconds. When VOLT:10 is issued, the power supply output goes to 10V for 0.1 seconds. Similarly, sending VOLT:TRIG 14, VOLT:MODE TRAN.05 and \*TRG causes the output to go to 14V for 0.05 seconds. If the time nn exceeds 2 seconds, error message -222 "dwell or frequency out range" is posted to the error queue.

VOLT:MODE EXT Configures the unit to use an external reference to change the main channel, whether voltage or current. (see PAR. 3.4);  $\pm 10V$  reference produces output =  $\pm E_o$  (rated) (Fixed gain =  $E_o$  (rated)). Identical to CURR:MODE EXT.

VOLT:MODE GAIN Configures the unit to use an external reference to provide a proportional output voltage.

VOLT:MODE PROT - allows main channel (CURR or VOLT) to accept values up to the protection limits of the power supply without generating an error. For example for a BOP 36-28G in current mode, after sending VOLT:MODE PROT, sending VOLT 36.4 would set the protection levels to 36.4 and main channel level to 36.

**Related Commands:** LIST commands. (See example, Figure B-5.)

## B.97 [SOURce:]VOLTage:MODE? QUERY

## VOLT:MODE?

Syntax: Short Form: [SOUR:]VOLT[:LEV]:MODE?  
Long Form: [SOURce:]VOLTage[:LEVel]:MODE?  
**Return value:** FIX, LIST, TRANS, EXT, or GAIN

Description: **Identifies active voltage mode.** See PAR. B.96 for further details **Related Commands:** LIST commands. (See example, Figure B-5.)

## B.98 [SOURce:]VOLTage[:LEVel]:PROTect:BOTH COMMAND

## VOLT:PROT[:BOTH]

Syntax: Short Form: [SOUR:]VOLT[:LEV]:PROT[:BOTH] <value>  
Long Form: [SOURce:]VOLTage[:LEVel]:PROTect[:BOTH] <value>  
where <value> is between minimum (box) value (Figure 1-3) and 1% above rated (nominal) output voltage.

Description: Establishes the both the positive and negative protection limits for voltage. If the protection limits are not identical the unit automatically reduces the appropriate limit (see Figure B-10).



NOTE: The power supply is assumed to be operating in constant voltage mode.	
VOLT:PROTECT:LIMIT:POS 5	Sets positive voltage protection limit to +5V.
VOLT:PROTECT:LIMIT:NEG 15	Sets negative voltage protection limit to -15V.
VOLT:PROTECT 10	Attempts to set voltage protection levels to ±10V. No error generated.
VOLT:PROT:POS?	Returns 5 (positive voltage protection set to +5V since 5 is less than 10).
VOLT:PROT:NEG?	Returns 10 (negative voltage protection set to -10V).
VOLT:PROTECT 18	Sets both voltage protection limits to +18V. No error generated.
VOLT:PROT:POS?	Returns 5 (positive voltage protection set to +5V since 5 is less than 18).
VOLT:PROT:NEG?	Returns 15 (negative voltage protection set to -15V, since 15 is less than 18).

**FIGURE B-10. USING PROT:LIM:POS AND PROT:LIM:NEG COMMANDS TO SET ASYMMETRICAL LIMITS**

**B.99 [SOURCE:]VOLTage[:LEVel]:PROTect[:BOTH]? QUERY VOLT:PROT[:BOTH]?**

Syntax: Short Form: [SOUR:]VOLT[:LEV]:PROT[:BOTH]?  
 Long Form: [SOURCE:]VOLTage[:LEVel]:PROTect[:BOTH]?  
 Returns <exp\_value>,<exp\_value>

Description: Identifies the protection limits for voltage (positive, negative); maximum is 1% greater than rated output voltage.

**B.100 [SOURCE:]VOLTage[:LEVel]:PROTect:MODE COMMAND VOLT:PROT:MODE**

Syntax: Short Form: [SOUR:]VOLT[:LEV]:PROT:MODE (EXT | FIX | LESS )  
 Long Form: [SOURCE:]VOLTage[:LEVel]:PROTect:MODE (EXTeRnal | FIXEd | LESSer )

Description: Determines how voltage protection limits are controlled.  
 FIXED - Allows the limits to be controlled by digital commands.  
 EXTERNAL: Allows both current and voltage limits to be controlled by analog signals applied to the analog port; limits set by SCPI command have no effect (see PAR. 3.4).  
 LESSER LIMIT: Allows protect limit to be automatically selected from either 1) the external analog voltage applied to the Analog I/O port or 2) the value set from SCPI command. Whichever limit has a lower absolute value (closest to zero) has effect.

**B.101 [SOURCE:]VOLTage[:LEVel]:PROTect:MODE? QUERY VOLT:PROT:MODE?**

Syntax: Short Form: [SOUR:]VOLT[:LEV]:PROT:MODE?  
 Long Form: [SOURCE:]VOLTage[:LEVel]:PROTect:MODE?  
 Returns FIX, EXT or LESS

Description: Identifies how voltage protection limits are controlled: FIX for Fixed, EXT for external, LESS for the lesser of the internal (fixed) and external protection limit values (See PAR. B.100 for details).

**B.102 [SOURCE:]VOLTage[:LEVel]:PROTect:NEGative COMMAND VOLT:PROT:NEG**

Syntax: Short Form: [SOUR:]VOLT[:LEV]:PROT:NEG <exp\_value>  
 Long Form: [SOURCE:]VOLTage[:LEVel]:PROTect:NEGative <exp\_value>  
 where <value> is between minimum (box) value (Figure 1-3) and 1% above rated (nominal) output voltage.

Description: Establishes the negative protection limit for voltage; maximum is 1% greater than rated output voltage.

**B.103 [SOURCE:]VOLTage[:LEVel]:PROTect:NEGative? QUERY VOLT:PROT:NEG?**

Syntax: Short Form: [SOUR:]VOLT[:LEV]:PROT:NEG?  
 Long Form: [SOURCE:]VOLTage[:LEVel]:PROTect:NEGative?  
 Returns: <exp\_value>

Description: Identifies the negative protection limit for voltage.

**B.104 [SOURce:]VOLTage[:LEVel]:PROTect:POSitive COMMAND****VOLT:PROT:POS**

Syntax: Short Form: [SOUR:]VOLT[:LEV]:PROT:POS <exp\_value>  
 Long Form: [SOURce:]VOLTage[:LEVel]:PROTect:POSitive <exp\_value>  
 where <value> is between minimum (box) value (Figure 1-3) and 1% above rated (nominal) output voltage.

Description: Establishes the positive protection limit for voltage; maximum is 1% greater than rated output voltage.

**B.105 [SOURce:]VOLTage[:LEVel]:PROTect:POSitive? QUERY****VOLT:PROT:POS?**

Syntax: Short Form: [SOUR:]VOLT[:LEV]:PROT:POS?  
 Long Form: [SOURce:]VOLTage[:LEVel]:PROTect:POSitive?  
 Returns: <exp\_value>

Description: Identifies the positive protection limit for voltage.

**B.106 [SOURce:]VOLTage[:LEVel]:PROTect:LIMit:BOTH COMMAND****VOLT:PROT:LIM[:BOTH]**

Syntax: Short Form: [SOUR:]VOLT[:LEV]:PROT:LIMit[:BOTH] <value>  
 Long Form: [SOURce:]VOLTage[:LEVel]:PROTect:LIMit[:BOTH] <value>  
 where <value> is between minimum (box) value (Figure 1-3) and 1% above rated (nominal) output voltage.

Description: Establishes the maximum value possible for both the positive and negative protection limits for voltage. Requires MEM:UPD (PAR. B.12) to save for power up. See PAR. 3.5.5.2 and Figure 3-6 for special programming considerations.

**B.107 [SOURce:]VOLTage[:LEVel]:PROTect:LIMit:BOTH? QUERY****VOLT:PROT:LIM[:BOTH]?**

Syntax: Short Form: [SOUR:]VOLT[:LEV]:PROT:LIMit[:BOTH]?  
 Long Form: [SOURce:]VOLTage[:LEVel]:PROTect:LIMit[:BOTH]?  
 Returns <exp\_value>,<exp\_value>

Description: Identifies the maximum value possible for protection limits for voltage (positive, negative); maximum is 1% greater than rated output voltage.

**B.108 [SOURce:]VOLTage[:LEVel]:PROTect:LIMit:NEGative COMMAND****VOLT:PROT:LIM:NEG**

Syntax: Short Form: [SOUR:]VOLT[:LEV]:PROT:LIM:NEG <exp\_value>  
 Long Form: [SOURce:]VOLTage[:LEVel]:PROTect:LIMit:NEGative <exp\_value>  
 where <value> is between minimum (box) value (Figure 1-3) and 1% above rated (nominal) output voltage.

Description: Establishes the minimum (maximum absolute) value possible for the negative protection limit for voltage. This may be set up to 1% greater than rated voltage. Requires MEM:UPD (PAR. B.12) to save for power up. See PAR. 3.5.5.2 and Figure 3-6 for special programming considerations.

**B.109 [SOURce:]VOLTage[:LEVel]:PROTect:LIMit:NEGative? QUERY****VOLT:PROT:LIM:NEG?**

Syntax: Short Form: [SOUR:]VOLT[:LEV]:PROT:LIM:NEG?  
 Long Form: [SOURce:]VOLTage[:LEVel]:PROTect:LIMit:NEGative?  
 Returns: <exp\_value>

Description: Identifies the minimum (maximum absolute) value possible for the negative protection limit for voltage.

**B.110 [SOURce:]VOLTage[:LEVel]:PROTect:LIMit:POSitive COMMAND**

**VOLT:PROT:LIM:POS**

Syntax: Short Form: [SOUR:]VOLT[:LEV]:PROT:LIM:POS <exp\_value>  
 Long Form: [SOURce:]VOLTage[:LEVel]:PROTect:LIMit:POSitive <exp\_value>  
 where <value> is between minimum (box) value (Figure 1-3) and 1% above rated (nominal) output voltage.  
 Description: Establishes the maximum value possible for the positive protection limit for voltage. This may be set up to 1% greater than rated voltage. Requires MEM:UPD (PAR. B.12) to save for power up. See PAR. 3.5.5.2 and Figure 3-6 for special programming considerations.

**B.111 [SOURce:]VOLTage[:LEVel]:PROTect:LIMit:POSitive? QUERY**

**VOLT:PROT:LIM:POS?**

Syntax: Short Form: [SOUR:]VOLT[:LEV]:PROT:LIM:POS?  
 Long Form: [SOURce:]VOLTage[:LEVel]:PROTect:LIMit:POSitive?  
 Returns: <exp\_value>  
 Description: Identifies the maximum value possible for the positive protection limit for voltage.

**B.112 [SOURce:]VOLTage[:LEVel]:TRIGgered[:AMPLitude] COMMAND**

**VOLT:TRIG**

Syntax: Short Form: [SOUR:]VOLT[:LEV]:TRIG[:AMP] <exp\_value>  
 Long Form: [SOURce:]VOLTage[:LEVel]:TRIGgered[:AMPLitude] <exp\_value>  
 <exp\_value> = digits with decimal point and Exponent, e.g., 2.71E1 for 27.1  
 Description: **Programs voltage value to be transferred to output by \*TRG command.** Actual output voltage will depend on load conditions. If the value exceeds the maximum for the model being programmed, error message -222, "Data out of range" is posted in output queue. If value exceeds VOLT:LIM:HIGH value, a value corresponding to the voltage limit will be programmed.

**B.113 [SOURce:]VOLTage[:LEVel]:TRIGgered[:AMPLitude]? QUERY**

**VOLT:TRIG?**

Syntax: Short Form: [SOUR:]VOLT[:LEV]:TRIG[:AMP]?  
 Long Form: [SOURce:]VOLTage[:LEVel]:TRIGgered[:AMPLitude]?  
**Return Value:** <exp\_value> = digits with decimal point and Exponent, e.g., 2.71E1 for 27.1  
 Description: **Returns value representing voltage value to be programmed by \*TRG command established by VOLT:TRIG command).**

**B.114 STATus:OPERation:CONDition? QUERY**

**STAT:OPER:COND?**

Syntax: Short Form: STAT:OPER:COND? Long Form: STATus:OPERation:CONDition?  
**Return Value:** <int\_value>  
 Description: **Returns the value of the Operation Condition Register (see Table B-3).** The Operation Condition Register contains unlatched real-time information about the operating conditions of the power supply. Bit set to 1 = function enabled (active, true); bit reset to 0 = function disabled (inactive, false). (See example, Figure B-11.)

**TABLE B-3. OPERATION CONDITION REGISTER, OPERATION ENABLE REGISTER, AND OPERATION EVENT REGISTER BITS**

CONDITION	NU	LR	NU	LC	SC	CC	TC	CV	NU	TA	WTG	NU
BIT	15	14	13	12	11	10	9	8	7	6	5	4 - 0
VALUE	32,768	16,384	8192	4096	2048	1024	512	256	128	64	32	16 -1

CC Constant Current Mode  
 CV Constant Voltage Mode  
 LC List Complete  
 LR List Running  
 NU Not Used  
 SC Sample Complete  
 TC Transient Complete  
 TA Transient Armed  
 WTG Waiting For Trigger

### B.115 STATus:OPERation:ENABle COMMAND

### STAT:OPER:ENAB

Syntax: Short Form: STAT:OPER:ENAB <int\_value>  
 Long Form: STATus:OPERation:ENABle <int\_value>

Description: **Sets Operation Enable Register.** The Operation Enable Register is a mask for enabling specific bits in the Operation Event Register which will cause the operation summary bit (bit 7) of the Status Byte register to be set Bit set to 1 = function enabled (active, true); bit reset to 0 = function disabled (inactive, false). The operation summary bit is the logical OR of all the enabled bits in the Operation Event register. (See example, Figure B-11.)

### B.116 STATus:OPERation:ENABle? QUERY

### STAT:OPER:ENAB?

Syntax: Short Form: STAT:OPER:ENAB? Long Form: STATus:OPERation:ENABle?  
**Return Value:** <int\_value>

Description: **Reads Operation Enable Register (see Table B-3).** Returns value of Operation Enable Register bits. Bit set to 1 = function enabled (active, true); bit reset to 0 = function disabled (inactive, false). (See example, Figure B-11.)

### B.117 STATus:OPERation[:EVENT] QUERY

### STAT:OPER?

Syntax: Short Form: STAT:OPER[:EVEN]? Long Form: STATus:OPERation[:EVENT]?  
**Return Value:** <int\_value>

Description: **Indicates changes in conditions monitored by Operational Event Register (see Table B-3).** Returns the value of the Operation Event register. The Operation Event register is a read-only register which holds (latches) all events that occur. Reading the Operation Event register clears it. (See example, Figure B-11.)

### B.118 STATus:PRESet COMMAND

### STAT:PRES

Syntax: Short Form: STAT:PRES Long Form: STATus:PRESet

Description: **Disables reporting of all status events.** This command sets the Operation Enabled Register (Table B-3) to 8193 and the Questionable Register to 255. (See example, Figure B-11.)

### B.119 STATus:QUESTionable[:EVENT]? QUERY

### STAT:QUES?

Syntax: Short Form: STAT:QUES[EVEN]? Long Form: STATus:QUESTionable[EVENT]?  
**Return Value:** <int\_value> actual register value

Description: **Indicates the latched condition of the Questionable Event register.** Returns the value of the Questionable Event register (see Table B-4). The Questionable Event register is a read-only register which holds (latches) all events. Only bits 13 and 12 are latched in the Status Questionable Event register. Bits 0 and 1 of the Status Questionable Condition Register are not latched in the power supply. Reading the Questionable Event register clears it. (See example, Figure B-11.)

**TABLE B-4. QUESTIONABLE EVENT REGISTER, QUESTIONABLE CONDITION REGISTER AND QUESTIONABLE CONDITION ENABLE REGISTER BITS**

CONDITION	NU	SINK	CE	VE	NU	SE	NU	TE	NU	CM	VM
BIT	15	14	13	12	11 - 7	6	5-4	3	2	1	0
VALUE	32,768	16,359	8192	4096	2048 - 128	64	32-16	8	4	2	1

CE Current Error  
 CM Current Mode Error  
 NU Not Used  
 SE Slave Error  
 SINK Power Supply absorbing energy from load  
 TE Thermal Error  
 VE Voltage Error  
 VM Voltage Mode Error

### B.120 STATus:QUESTionable:CONDition? QUERY

### STAT:QUES:COND?

Syntax: Short Form: STAT:QUES:COND? Long Form: STATus:QUESTionable:CONDition?  
**Return Value:** <int\_value> actual register value

Description: **Returns the value of the Questionable Condition Register (see Table B-4).** The Questionable Condition Register contains unlatched real-time information about questionable conditions of the power supply. Bit set to 1 = condition (active, true); bit reset to 0 = condition (inactive, false). Bits 1 or 0 may be both be set, indicating the power supply is settling after a voltage change. (See example, Figure B-11.)

## B.121 STATus:QUEStionable:ENABle COMMAND

## STAT:QUES:ENAB

Syntax: Short Form: STAT:QUES:ENAB <int\_value> Long Form: STATus:QUEStionable:ENABle <int\_value>

Description: **Programs Questionable Condition Enable Register (see Table B-4).** The Questionable Condition Enable Register determines which conditions are allowed to set the Questionable Condition Register; it is a mask for enabling specific bits in the Questionable Event register that can cause the questionable summary bit (bit 3) of the Status Byte register to be set. The questionable summary bit is the logical OR of all the enabled bits in the Questionable Event register. Bit set to 1 = function enabled (active, true); bit reset to 0 = function disabled (inactive, false). (See example, Figure B-11.)

NOTES: 1. The power supply is assumed to be operating in constant voltage (CV) mode.	
2. Examples below are intended only to illustrate command functions. Refer to PAR. for programming techniques to optimize performance.	
OUTP:ON	Sets output on.
STAT:PRES	Operation Condition and Questionable Condition registers are reset.
*CLS	Resets Enable Amplifier
STAT:QUES:ENAB 12228	Allows latching of CE and VE bits
STAT:OPER:ENAB 1280	Mask enabled for CC and CV bits.
STAT:OPER:ENAB?	Returns 1280 (256 + 1024) (CC and CV bits set).
INIT:CONT ON	Continuous triggers enabled.
STAT:OPER:COND?	Power supply returns 256 to indicate that power supply is in constant voltage mode.
FUNC:MODE:CURR	Commands power supply to current mode.
STAT:OPER?	Returns 1024, indicating that since the last reading of the Operation Event Register the power supply has entered Constant Current mode.
STAT:OPER?	Returns 0 indicating no changes since previous reading of the Operation Event register.
STAT:QUES?	Returns 0 (no questionable conditions occurred since previous reading
--- OVERCURRENT CONDITION OCCURS	
SYST:ERR?	Power supply returns 0, "No error" message.
*RST;:VOLT 5;CURR 1;OUTP ON	The BOP is in Voltage mode and delivering 5 Volts
*ESR?	Bop returns a 0 - all functions are normal
FUNC:MODE CURR	BOP is in Current mode
*ESR?;STAT:QUES:COND?	BOP returns 8;4097 - Current error.
*ESR?;STAT:QUES?	BOP returns 0;4096 - no new errors, Current Error
*ESR?;STAT:QUES?	BOP returns 0;0 - no new errors
MEAS:CURR?;VOLT?	BOP returns 1.0E-4;5.00003E0 - Voltage is 5 volts
STAT:QUES:COND?	BOP returns 4097 - error still in effect
	Short is applied to the BOP
*ESR?;STAT:QUES:COND?	BOP returns 0;1 - Current mode is selected
MEAS:VOLT?;CURR?	BOP returns .1E-4;1.00003E0 - Current is 1 amperes
FUNC:MODE VOLT;*ESR?	BOP switches mode, returns 3 - settling
*ESR?;:STAT:QUES?	BOP returns 8;8194
	Short is removed from the BOP output
STAT:QUES:COND?	BOP returns 2, voltage mode operation OK.

FIGURE B-11. USING STATUS COMMANDS AND QUERIES

**B.122 STATus:questionable:ENABle? QUERY****STAT:QUES:ENAB?**

Syntax: Short Form: STAT:QUES:ENAB? Long Form: STATus:QUESionable:ENABle?  
**Return Value:** <int\_value> actual register value

Description: **Reads Questionable Condition Enable Register (see Table B-4).** Power supply returns value of Questionable Condition Enable Register, indicating which conditions are being monitored. Bit set to 1 = function enabled (active, true); bit reset to 0 = function disabled (inactive, false). **Related Commands:** STAT:QUES?. (See example, Figure B-11.)

**B.123 SYSTem:BEEP COMMAND****SYST:BEEP**

Syntax: Short Form: SYST:BEEP Long Form: SYSTem:BEEP

Description: Causes the unit to emit a brief audible tone

**B.124 SYSTem:COMMunication:GPIB:ADDRess COMMAND****SYST:COMM:GPIB:ADDR**

Syntax: Short Form: SYST:COMM:GPIB:ADDR<INT VAL> 0 to 30  
 Long Form: SYSTem:COMMunication:GPIB:ADDRess<INT VAL> 0 to 30

Description: **Sets selected power supply GPIB address.** NOTE: After executing this command, subsequent commands must be directed to the new GPIB address. Requires MEM:UPD (PAR. B.12) to save for power up. See PAR. 3.5.5.2 and Figure 3-6 for special programming considerations.

**B.125 SYSTem:COMMunication:GPIB:ADDRess? QUERY****SYST:COMM:GPIB:ADDR?**

Syntax: Short Form: SYST:COMM:GPIB:ADDR?  
 Long Form: SYSTem:COMMunication:GPIB:ADDRess?  
**Return Value:** <int\_value> 0 to 30

Description: **Identifies selected power supply GPIB address.**

**B.126 SYSTem:COMMunication:SERial:BAUD COMMAND****SYST:COMM:SER:BAUD**

Syntax: Short Form: SYST:COMM:SER:BAUD {19200 | 9600 | 4800 | 2400}  
 Long Form: SYSTem:COMMunication:SERial:BAUD {19200 | 9600 | 4800 | 2400}

Description: **Sets the unit to operate at the specified baud rate.** See PAR. 3.5.5.2 and Figure 3-6 for special programming considerations.

**B.127 SYSTem:COMMunication:SERial:BAUD? QUERY****SYST:COMM:SER:BAUD?**

Syntax: Short Form: SYST:COMM:SER:BAUD?  
 Long Form: SYSTem:COMMunication:SERial:BAUD?  
**Return Value:** <int\_value> {19200 | 9600 | 4800 | 2400}

Description: **Returns operating baud rate.**

**B.128 SYSTem:COMMunication:SERial:ECHO COMMAND****SYST:COMM:SER:ECHO**

Syntax: Short Form: SYST:COMM:SER:ECHO {ON | OFF} or {01 | 00}  
 Long Form: SYSTem:COMMunication:SERial:ECHO {ON | OFF} or {01 | 00}

Description: **Enables (ON) or disables (OFF) echo mode** (see PAR. 3.6.4.2.2). Sending ON or 01 causes all subsequent characters to be echoed back. Sending OFF or 00 turns off the character echo after the next line terminator character. The \*RST command has no effect on echo status. See PAR. 3.5.5.2 and Figure 3-6 for special programming considerations.

**B.129 SYSTem:COMMunication:SERial:ECHO? QUERY****SYST:COMM:SER:ECHO?**

Syntax: Short Form: SYST:COMM:SER:ECHO?  
 Long Form: SYSTem:COMMunication:SERial:ECHO?  
**Return Value:** {01 | 00}

Description: **Returns 01 when echo mode is active (ON) or 00 when disabled (OFF)** (see PAR. 3.6.4.2.2).

### B.130 SYSTem:COMMunication:SERial:PACE COMMAND **SYST:COMM:SER:PACE**

Syntax: Short Form: SYST:COMM:SER:PACE {NONE | XON}  
Long Form: SYSTem:COMMunication:SERial:PACE {NONE | XON}

Description: **Enables (XON) or disables (NONE) data flow control via the serial interface (see PAR. 3.6.4.2.1).**  
See PAR. 3.5.5.2 and Figure 3-6 for special programming considerations.

### B.131 SYSTem:COMMunication:SERial:PACE? QUERY **SYST:COMM:SER:PACE?**

Syntax: Short Form: SYST:COMM:SER:PACE?  
Long Form: SYSTem:COMMunication:SERial:PACE?  
Return Value: {01 | 00}

Description: **Returns 01 when data flow control via the serial interface is enabled (XON) or 00 when disabled (NONE) (see PAR. 3.6.4.2.1).**

### B.132 SYSTem:COMMunication:SERial:PROMpt COMMAND **SYST:COMM:SER:PROM**

Syntax: Short Form: SYST:COMM:SER:PROM {ON | OFF} or {0 | 1}  
Long Form: SYSTem:COMMunication:SERial:PROMpt {ON | OFF} or {0 | 1}

Description: **Enables (1 or ON) or disables (0 or OFF) prompt (see PAR. 3.6.4.2.3).** Sending 1 or ON causes the unit to return > character after the command is parsed. See PAR. 3.5.5.2 and Figure 3-6 for special programming considerations.

### B.133 SYSTem:COMMunication:SERial:PROMpt? QUERY **SYST:COMM:SER:PROM?**

Syntax: Short Form: SYST:COMM:SER:PROM?  
Long Form: SYSTem:COMMunication:SERial:PROMpt?  
Return Value: {1 | 0}

Description: **Returns 1 when prompt is enabled (ON) or 0 when disabled (OFF).** (See PAR. 3.6.4.2.3.)

### B.134 SYSTem:ERRor? QUERY **SYST:ERR?**

Syntax: Short Form: SYST:ERR? Long Form: SYSTem:ERRor?  
**Return Value:** <int\_value,string>

Description: **Posts error messages to the output queue.** Returns the next error number followed by its corresponding error message string from the instrument error queue. The error queue is a FIFO (first in first out) buffer that stores errors as they occur. As it is read, each error is removed from the queue and the next error message is made available. When all errors have been read, the query returns 0,"No error". If more errors are accumulated than the queue can hold, it will overflow. The oldest errors stay in the queue but the most recent errors are discarded. The last error in the queue will be -350,"Queue Overflow." Error messages are defined in Table B-5.

### B.135 SYSTem:ERRor:CODE? QUERY **SYST:ERR:CODE?**

Syntax: Short Form: SYST:ERR:CODE? Long Form: SYSTem:ERRor:CODE?

Description: Returns the three character error code without the ASCII definition string. The error codes are defined in table B-5 (See example, Figure B-13.)

### B.136 SYSTem:ERRor:CODE:ALL? QUERY **SYST:ERR:CODE:ALL?**

Syntax: Short Form: SYST:ERR:CODE:ALL? Long Form: SYSTem:ERRor:CODE:ALL?  
Return Value:

Description: Returns a comma-separated list of all error codes. A maximum of 31 codes will be returned; if the queue is empty, the power supply returns 0.

### B.137 SYSTem:KEYBoard COMMAND **SYST:KEYB**

Syntax: Short Form: SYST:KEYB [DIS | ENAB] Long Form: SYSTem:KEYBoard [DISable | ENABle]

Description: Limited functionality; included for compatibility with other Kepco products. (Locks (DIS) or unlocks (ENAB) a front panel keypad.)

**B.138 SYSTem:KEYBoard? QUERY****SYST:KEYB?**

Syntax: Short Form: SYST:KEYB? Long Form: SYSTem:KEYBoard?  
Returns: 1 or 0

Description: Limited functionality; included for compatibility with other Kepco products. (Identifies the state of a keypad: locked = 1 or unlocked = 0.)

**B.139 SYSTem:PASSword:CENable COMMAND****SYST:PASS:CEN**

Syntax: Short Form: SYST:PASS:CEN <val>  
Long Form: SYSTem:PASSword:CENable <val>

Description: Sets the password enable state if the <value> matches the current password. This command allows CALibrate commands to operate.

**B.140 SYSTem:PASSword:CDISable COMMAND****SYST:PASS:CDIS**

Syntax: Short Form: SYST:PASS:CDIS Long Form: SYSTem:PASSword:CDISable

Description: Clears the password enable state.

**B.141 SYSTem:PASSword:NEW COMMAND****SYST:PASS:NEW**

Syntax: Short Form: SYST:PASS:NEW <old password>,<new password>  
Long Form: SYSTem:PASSword:NEW <old password>,<new password>

Description: **Establishes new password.** The old (current) password is checked, then replaced by the new password. (See example, Figure B-13.) See PAR. 3.5.5.2 and Figure 3-6 for special programming considerations.

**B.142 SYSTem:PASSword:STATe? QUERY****SYST:PASS:STAT?**

Syntax: Short Form: SYST:PASS:STAT? Long Form: SYSTem:PASSword:STATe?  
Return Value: <int\_value> 0 or 1

Description: Returns a 1 if the password state is enabled or a 0 if it is disabled.

**B.143 SYSTem:REMote COMMAND****SYST:REM**

Syntax: Short Form: SYST:REM {ON | OFF} or {1 | 0}  
Long Form: SYSTem:REMote {ON | OFF} or {1 | 0}

Description: **Used during serial (RS 232) communication to set the unit to remote (1 or ON) or local (0 or OFF) mode.** This command must be issued prior to commands that affect the power supply output (e.g., VOLT 10;:OUTP ON) to ensure the unit is in remote mode. See PAR. 3.6.4.3 and Figure B-12.

**B.144 SYSTem:REMote? QUERY****SYST:REM?**

Syntax: Short Form: SYST:REM? Long Form: SYSTem:REMote?  
Return Value: {1 | 0}

Description: **Identifies whether unit it in remote mode (1) or local mode (0) during serial (RS 232) communication.** See PAR. 3.6.4.3 and Figure B-12.

*IDN?	Unit responds with KEPKO,BOP 50-20,E1234,1.66 (typical).
OUTP?	Unit responds with 0 indicating output is off
SYST:REM?	Unit responds with 0 indicating unit is in local mode.
SYST:REM 1	Puts unit in remote mode.
OUTP ON	Enables output
OUTP?	Unit responds with 1 (output on).
SYST:REM 0	Unit set to local mode.

**FIGURE B-12. SETTING THE UNIT TO REMOTE MODE VIA SERIAL (RS 232) PORT**



### B.145 SYSTem:SECurity:IMMEDIATE COMMAND

## SYST:SEC:IMM

Syntax: Short Form: SYST:SEC:IMM Long Form: SYSTem:SECurity:IMMEDIATE

Description: **Initializes all NVRAM variable to factory defaults.** Empties all memory locations and sets limits to factory defaults:

Voltage Mode:  $\pm$ Voltage max/min to  $E_{Onom}$ , +Current Protect max to  $1.01 \times I_{Onom}$ , -Current Protect min to  $1.01 \times I_{Onom}$ , +Current Protect min and -Current Protect max to minimum (box).

Current Mode:  $\pm$ Current max/min to  $I_{Onom}$ , +Voltage Protect max to  $1.01 \times E_{Onom}$ , -Voltage Protect min to  $1.01 \times E_{Onom}$ , +Voltage Protect min and -Voltage Protect max to minimum (box).

See PAR. 3.5.5.2 and Figure 3-6 for special programming considerations. This command is password protected (must be preceded by SYST:PASS:CEN (see PAR B.139).

### B.146 SYSTem:SET COMMAND

## SYST:SET

Syntax: Short Form: SYSTem:SET {CM0 | CM1 | DCL0 | DCL1 | LF0 | LF1 | RO0 | RO1}  
Long Form: SYSTem:SET {CM0 | CM1 | DCL0 | DCL1 | LF0 | LF1 | RO0 | RO1}

Description: **Establishes Device Clear, Line Feed, OUTF command and Reset functions. Sending SYST:SEC:IMM sets LF1, DC0, and RO0 (as if CM0 was sent).** Requires MEM:UPD (PAR. B.12) to save for power up. See PAR. 3.5.5.2 and Figure 3-6 for special programming considerations.

DCL0 Device Clear functions per IEEE 488.2 Standard. (No effect on the device (power supply), only clears internal status registers.)

DCL1 Device Clear functions identical to \*RST (Output set to 0V, voltage mode and output set to OFF except if RO1 (see below) is set.)

LF0 Line Feed not provided upon empty buffer condition

LF1 Line Feed provided if buffer is empty and a read is performed.

RO0 \*RST and power up set output to OFF, 0V, 0A, voltage mode.

RO1 \*RST sets output to ON, 0V, 0A, voltage mode. Subsequent VOLT and CURR commands are immediately present at the output without sending OUTF ON (OUTP OFF and OUTF ON function normally to turn the output off or on.)

CM0 Establishes DCL0, LF0, RO0 conditions described above. (SCPI 1997 Standard compliance)

CM1 Establishes DCL1, LF1, RO1 conditions described above. (Compatible with software versions 1.2 and earlier) (See example, Figure B-13.)

### B.147 SYSTem:SET? QUERY

## SYST:SET?

Syntax: Short Form: SYST:SET? Long Form: SYSTem:SET?  
Return Value: DCL<n>,LF<n>,RO<n> where n = 0 or 1

Description: **Identifies functions established by SYST:SET command.** (See example, Figure B-13.)

### B.148 SYSTem:VERSion? QUERY

## SYST:VERS?

Syntax: Short Form: SYST:VERS? Long Form: SYSTem:VERSion?  
Return Value: <int\_value>.<int\_value> (YYYY.V)

Description: **Identifies SCPI Version implemented.** Returns SCPI Version number:  
YYYY = year, V = Revision number for specified year. (See example, Figure B-13.)

SYST:VERS?	Unit returns 1997
SYST:SET?	Unit returns DC0,LF0,RL0,OUT0
SYST:PASS:NEW DEFAULT,OKAY	Unit changes password to be OKAY
SYST:SET LF1,RL1,DC1	Configures Device Clear, Line Feed and Reset (see PAR. B.146).
SYST:PASS:CEN OKAY	Password enabled commands are accepted
MEM:UPDATE INTERFACE	Unit saves the LF1 state for next power on cycle.

FIGURE B-13. USING SYSTEM COMMANDS AND QUERIES

## B.149 TRIGger:SOURce COMMAND

## TRIG:SOUR

Syntax: Short Form: TRIG:SOUR {BUS | EXT | IMM}  
 Long Form: TRIGger:SOURce {BUS | EXT | IMM}

Description: **Selects the active trigger source.** When TRIG:SOUR BUS is set, an event trigger is created by sending either \*TRG or GPIB <GET> commands. When TRIG:SOUR EXT is set, the trigger is created by connecting the external trigger line (J2, pin 4 or pin 3 of the mating connector for J2) to analog signal ground (J2, pin 1 or J2 mating connector, pin 1). The trigger must be armed by sending either INIT:IMM or INIT:CONT enable (ON) commands prior to sending the selected trigger command. (see PAR. A.16). Receipt of the active trigger causes the power supply to program to the previously stored values of VOLT:TRIG and CURR:TRIG (actual output voltage/current is dependent upon the load). Sending TRIG:SOUR IMM causes the next VOLT:TRIG or CURR:TRIG to immediately program the output, regardless of trigger arming. \*RST sets TRIG:SOUR to IMMEDIATE. Related Commands: <GET>, \*TRG, INIT:IMM, INIT:CONT.

## B.150 TRIGger:SOURce? QUERY

## TRIG:SOUR?

Syntax: Short Form: TRIG:SOUR? Long Form: TRIGger:SOURce?  
 Returns: BUS, IMMEDIATE or EXTERNAL

Description: **Identifies whether internal, immediate or external trigger is activated.**

**TABLE B-5. ERROR MESSAGES**

ERROR MESSAGE	ESR ERROR BIT SET (SEE PAR. A.5)	EXPLANATION
0,"No error"	None	No error
1,"Interprocessor communications error"	Device Error bit 3 <sup>(1)</sup>	Interprocessor communications error
2,"Configuration error"	Device Error bit 3 <sup>(1)</sup>	Configuration error
10,"Program Error"	Device Error bit 3 <sup>(1)</sup>	Program error
1xx01,"A3 Output Temperature Error" 1xx02,"A2 Output Temperature Error" 1xx03,"Output Overcurrent" 1xx04,"Output Overvoltage" 1xx05," A2 Instant Overcurrent" 1xx06,"A2 (+)15V BUS Missing" 1xx07,"A3 Overcurrent" 1xx08,"A4 Module Temperature Error" 1xx09,"A4 Output Voltage Error" 1xx10,"A4 Input Section Error" 1xx11,"A2 Input Over Current Error" 1xx12,"A4 (-)15VS Missing"	Device Error bit 3 <sup>(1)</sup>	Indicates the power supply or one of the connected power supplies has detected an error. These errors are an indication of a hardware problem in either the BOP or the BOP system consisting of a master and up to four slave BOPs to create additional current or voltage. The last two digits of the error code indicate the type of error and its source; xx indicates the position of the unit on the BITBUS: xx = 1: Device 1 (Master) xx = 2: Device 1 (Slave 1) xx = 3: Device 1 (Slave 2) xx = 4: Device 1 (Slave 3) xx = 5: Device 1 (Slave 4)
2yy01,"OVER TEMPERATURE" 2yy02,"CROWBAR ACTIVE" 2yy03,"DEVICE TURNED OFF" 2yy04,"CURRENT FAULT" 2yy05,"POWER LOSS" 2yy06,"VOLTAGE FAULT" 2yy07,"RELAY OPEN" 2yy08,"POLARITY ERROR" 2yy09,"OVERLOAD"	Device Error bit 3 <sup>(1)</sup>	Indicates a hardware problem has been detected in either the BOP power supply or an auxiliary power supply, such as Kepco's MST, MAT, MBT or low power (under 1KW) BOP, connected to the BITBUS. The last two digits of the error code indicate the type of error detected,; yy indicates the position of the unit on the BITBUS yy = 2: Device 2 through yy = 15: Device 15
-100,"Command error"	Command Error bit 5	Command and data understood, but more information included which is not recognized.
-120,"Numeric data error"	Command Error bit 5	Expected number but other characters were detected
-203,"Command Protected"	Execution error bit 4	Password must be CENabled
(1)	The Device error bit may be set when the status monitoring functions of the power supply detect an overvoltage/under-voltage condition.	

**TABLE B-5. ERROR MESSAGES (CONTINUED)**

ERROR MESSAGE	ESR ERROR BIT SET (SEE PAR. A.5)	EXPLANATION
-221,"Settings Conflict"	Execution error bit 4	Calibration state not enabled but CALibrate command received
-222,"Current, Voltage or Data out of range"	Execution error bit 4	Value (current or voltage) exceeds power supply rating or (data) exceeds acceptable command parameters
-223,"Too Much Data"	Execution error bit 4	During a LIST command, the list became full, preventing all the data from being added to the list
-226,"Lists not same length"	Execution error bit 4	During a LIST command, number of DWEL list entries was not equal to 1 and did not match number of LIST:VOLT or LIST:CURR entries.
-240,"Hardware error"	Execution error bit 4	Power supply did not respond to command.
-242,"Voltage comparison error"	Execution error bit 4	Issued during Voltage calibration (Volt [zero, max, min], voltage external protect, Voltage in series) indicating the measurements are incorrect.
-243, "Current comparison error"	Execution error bit 4	Issued during Current Calibration (Current (max, min or Zero, Current external limit, slave input) indicating the measurements are incorrect.
-249,"Master Not Found"	Execution error bit 4	The slave controller for a multiple unit configuration has not detected a master unit. - this is an operator error as the slave should not be operated over the GPIB interface.
-311,"Memory Error"	Device Error bit 3 <sup>(1)</sup>	*SAV (save), *RCL (recall), MEMory:SAVE, MEMory:UPDAte or CALibrate:STORE error
-314,"Save/recall Memory Lost"	Device Error bit 3 <sup>(1)</sup>	A memory location that was saved earlier was lost due to a flash error in Analog processor memory.
-340,"Calibration Failed"	Device Error bit 3 <sup>(1)</sup>	The calibration results were invalid. This normally indicates an incorrect calibration caused by operator error such as performing a current calibration without a load, or a voltage calibration with a load.
-350,"Queue Overflow"	Device Error bit 3 <sup>(1)</sup>	Error queue was full, error events have been lost.
-363,"Input buffer overrun"	Device Error bit 3 <sup>(1)</sup>	The input from the controlling computer was longer than 253 characters in length.
-370,"A2 External Error"	Device Error bit 3 <sup>(1)</sup>	Either external input error (A2A5 optocoupler) or an A2 error occurred that could not be defined by evaluating PAL latches.
-400,"QueryError"	Query Error bit 2	Data requested was lost due to 253 character limit or BIT 4886 output buffer
-420,"Query Unterminated"	Query Error bit 2	Controller sent query but did not accept data from power supply. See VOLT? (PAR. B.89), CAL:SAVE (PAR. B.89) commands
-440,"Missing Query"	Query Error bit 2	Controller sent MEM:PACK, MEM:UPD, SYST:SEC:IMM or SYST:SEC:OVER without preceding command with query or following the command with ;*OPC? (see PAR. 3.5.5.2 for details.)
(1)	The Device error bit may be set when the status monitoring functions of the power supply detect an overvoltage/under-voltage condition.	

