

OPERATOR'S MANUAL

BOP (M) (D) 100W, 200W, 400W BIPOLAR OPERATIONAL POWER SUPPLY

100W: BOP 5-20, 20-5, BOP 50-2, BOP 100-1
200W: BOP 5-30, BOP 20-10, BOP 36-6, BOP 50-4, BOP 72-3, BOP 100-2, BOP 200-1
400W: BOP 20-20, BOP 36-12, BOP 50-8, BOP 72-6, BOP 100-4

KEPCO INC.

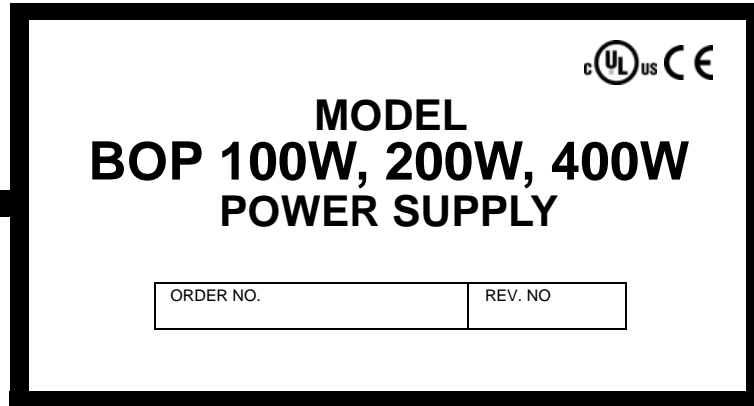

IMPORTANT NOTES:

- 1) This manual is valid for the following Model and associated serial numbers:

MODEL	SERIAL NO.	REV. NO.
-------	------------	----------
- 2) A Change Page may be included at the end of the manual. All applicable changes and revision number changes are documented with reference to the equipment serial numbers. Before using this Instruction Manual, check your equipment serial number to identify your model. If in doubt, contact your nearest Kepco Representative, or the Kepco Documentation Office in New York, (718) 461-7000, requesting the correct revision for your particular model and serial number.
- 3) The contents of this manual are protected by copyright. Reproduction of any part can be made only with the specific written permission of Kepco, Inc.

Data subject to change without notice.

©2024, KEPCO, INC
P/N 243-1308-r21a



KEPCO, INC. • 131-38 SANFORD AVENUE • FLUSHING, NY. 11355 U.S.A. • TEL (718) 461-7000 • FAX (718) 767-1102
email: hq@kepcopower.com • World Wide Web: www.kepcopower.com

TABLE OF CONTENTS

SECTION	PAGE
SECTION 1 - INTRODUCTION	
1.1	Scope of Manual..... 1-1
1.2	Options 1-2
1.2.1	Meters (M Suffix, D suffix):..... 1-2
1.2.2	Capacitive Load Optimization (C Suffix):..... 1-2
1.2.3	Inductive Load Optimization (L Suffix):..... 1-2
1.2.4	Digital Remote Control (4886 SUFFIX, 802E Suffix)..... 1-2
1.3	General Description..... 1-3
1.4	Electrical Specifications, General 1-3
1.5	Miscellaneous Features..... 1-12
1.5.1	Output Range 1-12
1.5.2	Rear Programming Features..... 1-12
1.5.3	Remote ON-OFF Feature..... 1-16
1.5.4	Load Reactance 1-16
1.5.4.1	Driving an Inductive Load in Current Mode 1-16
1.5.4.2	Driving a Capacitive Load in Voltage Mode 1-17
1.5.5	Remote Turn-off 1-17
1.5.6	Circuit Breaker Shutdown Prevention (at Power Loss) Circuit 1-17
1.5.7	References 1-17
1.5.8	Series Or Parallel Operation 1-17
1.5.9	Voltage Control Channel 1-17
1.5.10	External Voltage Monitor 1-17
1.5.11	External Current Monitor 1-18
1.5.12	Mode Switch..... 1-18
1.5.13	Current Control Channel 1-18
1.5.14	Bounding 1-18
1.5.15	Mode Lights..... 1-19
1.5.16	Remote (W/ DIG ON) / Out ON (W/ DIG OFF) LED..... 1-19
1.5.17	Standards 1-19
1.6	Mechanical Specifications 1-19
1.7	Equipment Supplied..... 1-19
1.8	Accessories 1-20
1.9	Safety..... 1-20
SECTION 2 - INSTALLATION	
2.1	Unpacking and Inspection. 2-1
2.2	Terminations, Controls and Indicators 2-1
2.3	A-C Input Requirements 2-3
2.4	Cooling..... 2-4
2.5	Preliminary Checkout..... 2-4
2.6	Installation of Full-rack BOP Models..... 2-6
2.6.1	Slide Installation. 2-7
2.7	Load Connection..... 2-8
2.7.1	Load Connection, Local Sensing..... 2-8
2.7.2	Load Connection, Remote Sensing..... 2-8
2.7.3	A-c Ground 2-8
2.7.4	D-c Ground..... 2-9
SECTION 3 - OPERATION	
3.1	Introduction 3-1
3.2	Power Supply Basics 3-1
3.2.1	Safety Precautions 3-1
3.2.2	Simplified Application and Test Setup Diagrams 3-2
3.2.3	Rear Programming Connector 3-2
3.2.4	External Programming Resistors..... 3-3
3.2.5	Active Programming Sources..... 3-4

TABLE OF CONTENTS

SECTION	PAGE
3.2.6	External Leads..... 3-4
3.2.7	External Voltage Monitor 3-4
3.2.8	External Current Monitor..... 3-4
3.3	Local (Front Panel) Output Control 3-4
3.3.1	Voltage Mode Operation with Current Limiting..... 3-4
3.3.2	Local Control of Current Limiting 3-6
3.3.3	Current Mode Operation with Voltage Limiting..... 3-7
3.3.4	Local Control of Voltage Limiting..... 3-8
3.4	Remote Control of Voltage Channel 3-9
3.4.1	Remote Voltage Control Using Resistance (Potentiometer)..... 3-9
3.4.2	Remote Voltage Control Using Resistance (Decade Box) 3-10
3.4.3	Remote Voltage Control Using D-C Signal Voltage..... 3-11
3.4.4	Using the BOP as a Voltage Amplifier 3-13
3.4.5	Remote Control of Current Limiting 3-15
3.5	Remote Control of Current Control Channel..... 3-16
3.5.1	Remote Current Control Using Resistance (Potentiometer)..... 3-17
3.5.2	Remote Current Control Using Resistance (Decade Box)..... 3-17
3.5.3	Remote Current Control Using D-C Signal Voltage..... 3-18
3.5.4	Using the BOP as a Current Amplifier 3-19
3.5.5	Remote Control of Voltage Limiting..... 3-20
3.6	Series and Parallel Connection of BOP Power Supplies 3-22
3.6.1	Series Connection, Master/slave Operation 3-23
3.6.2	Circuit Breaker Control Circuit 3-24
3.6.3	Parallel Connection, Master/Slave Operation..... 3-26
3.7	Indicator And Flag Logic Circuit 3-29
3.8	Digital Control of BOP Power Supplies 3-30

SECTION 4 - CALIBRATION

4.1	Introduction 4-1
4.2	Test Equipment Requirements 4-2
4.3	Internal Adjustments and Calibrations 4-3
4.3.1	Adjustment of ± 10 Volt Calibration Controls (R31, R32) 4-3
4.3.2	Preamplifier "A" Zero (R41) 4-4
4.3.3	Preamplifier "B" Zero (R42) 4-4
4.3.4	Voltage Channel Zero Adjustment (R81)..... 4-5
4.3.5	Ammeter Zero Control Adjustment (R50) 4-5
4.3.6	Current Channel Zero Adjustment (R83) 4-5
4.3.7	Full Scale Output Current Calibration (R316/R314) 4-6
4.3.8	Adjustment of Optocoupler Linearization Control R15A (Model BOP 200-1 only)..... 4-6
4.3.9	Adjustment of I_O -OFF Zero (A1R133) and E_O -OFF Zero (A1R136) 4-8

LIST OF FIGURES

FIGURE	TITLE	PAGE
1-2	BOP Output Characteristic.....	1-12
1-3	BOP Output WaveForms with Phase Shift	1-13
1-4	Boundaries and Limits	1-18
1-5	Mechanical Outline Drawing, (BOP 3/4 Rack Models).....	2-21
1-6	Mechanical Outline Drawing, (BOP Full Rack Models).....	2-23
2-1	BOP Terminations and Controls, Front Panel.....	2-1
2-2	BOP Terminations and Controls, Rear Panel	2-3
2-3	A-C Source Voltage Selection	2-3
2-4	Slide Installation on Full-rack Units.....	2-7
2-5	Load Connection Using Local Sensing at Rear Panel	2-10
2-6	Load Connection Using Local Sensing at Front Panel	2-10
2-7	Load Connection Using Remote Sensing at Rear Panel	2-11
2-8	Load Connection Using Remote Sensing at Front Panel	2-11
3-1	How to Modify Connections of PC 15 Rear Programming Connector, Using Note 2 of Figure 3-22 as an Example.....	3-3
3-2	BOP Voltage Control Channel (Local Control, Local Sensing)	3-5
3-3	BOP (\pm) Current Limiting Circuit (Local Control, Local Sensing)	3-6
3-4	BOP Current Control Channel (Local Control, Local Sensing)	3-7
3-5	BOP (\pm) Voltage Limiting Circuit (Local Control, Local Sensing)	3-8
3-6	Remote Potentiometer Control of D-C Output Voltage	3-9
3-7	Remote D-C Output Voltage Control Using Two-Terminal Resistance (Decade).....	3-10
3-8	Digital Control of the D-C Output Voltage	3-11
3-9	D-C Output Voltage Control with Non-inverting Configuration and High Impedance $\pm 1V$ Signal Source... ..	3-12
3-10	Graphs Of Possible Input/output Waveshapes	3-13
3-11	Basic Programming Circuit for Use of BOP as Bipolar Amplifier (Voltage Mode).....	3-14
3-12	Programming Circuit for Driving Output Voltage with $\pm 1V$ Input Programming Voltage	3-15
3-13	Symmetrical Remote Control of the Current Limits.....	3-16
3-14	Independent Remote Control of $+ I_O$ and $- I_O$ Limits.....	3-16
3-15	Remote Potentiometer Control of the BOP Output Current	3-17
3-16	Remote D-C Output Current Control Using Two-Terminal Resistance (Decade).....	3-17
3-17	Digital Control of Output Current.....	3-18
3-18	BOP Output Current Control with Non-inverting Configuration and High Impedance (± 1 Volt Signal Source	3-18
3-19	Basic Programming Circuit for BOP as Bipolar Current-stabilized Amplifier.....	3-19
3-20	Programming Circuit for Driving Output Current with $\pm 1V$ Input Programming Voltage.....	3-19
3-21	Programming Circuit for Driving Output Current with a High Impedance Source	3-20
3-22	Symmetrical Remote Control of Voltage Limit	3-21
3-23	Independent Remote Control of $+E_O$ and $-E_O$ Voltage Limit.....	3-21
3-24	Series Connection (Master/Slave) of two BOP Power Supplies, with Remote Error Sensing at the Common Load.....	3-24
3-25	Circuit Breaker Control Circuit, Simplified Diagram.	3-25
3-26	Parallel Connection (Master/Slave) of Two BOP Power Supplies with Remote Error Sensing at the Common Load.....	3-27
3-27	Alternative Parallel Connection (Master/Slave) for Greater Precision and Stability of Two or More BOP Power Supplies	3-28
3-28	Indicator Light and Flag Logic.....	3-29
3-29	Simplified Schematic Diagram, BOP 100W, 200W, 400W	3-31
3-30	PC 15/PC 12 Rear Programming Connector Interconnections	3-33
4-1	Locations of Adjustment and Calibration Controls	4-2
4-2	A1 Board, Test Point (TP) Location	4-7
4-3	Optocoupler Linearization (BOP 200-1 only)	4-8

LIST OF TABLES

TABLE	TITLE	PAGE
1-1	General Specifications	1-4
1-2	Input Specifications	1-9
1-3	Output Ranges, Transfer Factor and Output Impedance	1-10
1-4	Output Dynamic Specifications	1-11
1-5	Rear Programming Connector Terminal Functions	1-13
1-6	Equipment Supplied	1-19
1-7	Accessories - Not Supplied	1-20
1-8	Safety Symbols	1-20
2-1	BOP Front Panel Terminations and Controls	2-1
2-2	BOP Rear Panel Terminations and Controls	2-3
2-3	Preliminary Checkout Readings	2-5
2-4	Chassis Slide Mounting Holes	2-7
4-1	Internal Adjustments and Calibrations	4-1
4-2	Suggested Sense Resistors	4-3



FIGURE 1-1. BOP 100W, 200W, 400W POWER SUPPLY

SECTION 1 - INTRODUCTION

1.1 SCOPE OF MANUAL.

This manual contains instructions for the installation and operation of the BOP series of 100, 200 and 400 Watt bipolar operational power supplies manufactured by Kepco, Inc., Flushing, New York, U.S.A.

This manual covers only **newer models** of BOP. Newer models can be identified by the indicator located between the two front panel meters.

Newer Models. On newer models the indicator between the two front panel meters is labeled REMOTE (W DIG ON)/OUT ON (W DIG OFF, and is a dual function indicator. When digital programming is ON (optional BIT card in use), the indicator is on to show remote mode. When digital programming is OFF (BIT card not installed or not in use), the indicator only goes on when the OUTPUT is ON (enabled) and is off to indicate the output is OFF (disabled). Newer models include the remote output on-off feature as well as some differences in pin allocation of the rear programming connector as listed below. Isolated remote on-off control of the output and associated flag signal is configured at the PC 15 programming connector as follows.

- pins 12 and 14 (previously used for shifting between A and AB class configurations) used for external compensation in voltage mode.
- pin 21 (previously unused) is used for either a) logic selection of isolated output on-off control or b) non-isolated output on-off control, if isolated output on-off is not used.
- pin 46 (previously unused) is used for the remote output on-off flag.
- pin 48 (previously shorted to pin 47) is now the return for isolated output on-off control and flag (pin 47 unchanged).
- pin 50 (previously shorted to pin 49) now used as isolated output on off control (pin 49 unchanged).

Older Models: Older models have a REMOTE indicator located between the two front panel meters. When the unit includes an optional BIT card, this indicator lights when the BIT card is in use (unit is under remote control). Older models do not have the remote output on-off feature. The manual covering older models can be downloaded at:

<http://www.kepcopower.com/support/bop-operator-r7.pdf>

For retrofit of an older model to a newer model that includes the remote output ON-OFF feature, please contact Kepco.

Throughout this manual E_O represents the rated output voltage, and I_O represents the rated output current as defined by E_O MAX and I_O MAX, respectively in Table 1-3 for each model.

1.2 OPTIONS

BOP options are described below; more than one option may be incorporated into any BOP Power Supply.

1.2.1 METERS (M SUFFIX, D SUFFIX): M suffix models include one analog voltage meter and one current meter on the front panel. D suffix models include two digital meters on the front panel used to display voltage and current.

1.2.2 CAPACITIVE LOAD OPTIMIZATION (C SUFFIX): Models with a C suffix have been modified to be stable handling capacitive loads up to 10mF. A Modification Sheet describing changes and modified specifications can be downloaded from the Kepco web site at:
www.kepcopower.com/support/opmanls.htm#bop.

1.2.3 INDUCTIVE LOAD OPTIMIZATION (L SUFFIX): Models with an L suffix have been modified to be stable handling inductive loads up to 1 Henry. A Modification Sheet describing changes and modified specifications can be downloaded from the Kepco web site at:
www.kepcopower.com/support/opmanls.htm#bop.

1.2.4 DIGITAL REMOTE CONTROL (4886 SUFFIX, 802E SUFFIX) 4886 suffix models include a factory installed BIT 4886 card that allows remote control via GPIB or RS 232 protocols using SCPI commands. 802E suffix models include a factory-installed BIT 802E card that allows remote control via a LAN using SCPI commands. These cards may also be purchased separately and installed by the user. Use of these cards is documented in the associated BIT card manual that can be downloaded from the Kepco web site at:
www.kepcopower.com/support/opmanls.htm#bit



CAUTION: The application schematic diagrams found in Section 3, Operation, are valid for analog control only. If a digital card is installed, analog control is only possible if the digital card is disabled. See application note titled “How to Disable BIT Card in a) BOP models with BIT 802E or 4886 Cards Installed or b) BOP 2X-DE Models” that can be downloaded from the Kepco web site at:
www.kepcopower.com/support/bop-app-note.htm

1.3 GENERAL DESCRIPTION.

Kepeco Series BOP Bipolar Power Supplies are fully dissipative, linear stabilizers for laboratory and systems applications. The BOP is an all solid-state design, featuring IC operational amplifiers in the control circuit section and silicon power transistors mounted on special fan-cooled heat sinks in the complementary power stage.

Remote digital control of the BOP is possible using one of two optional digital interface cards (see Table 1-7). BIT 4886 allows communication via RS 232 or GPIB protocols, BIT 802E allows communication via web pages using a browser. IVI-COM, LabView and LabWindows Drivers are available for both cards. An EPICS driver is available for the BIT 802E.

The BOP has two bipolar control channels (voltage or current mode), selectable and individually controllable either from their front panel controls, or by remote signals. The BOP output is protected by bipolar limit circuits. In these limit circuits the positive and negative current or voltage limit points can be manually set or remotely programmed simultaneously or individually. Automatic crossover between each principal control channel and its associated limit channel is provided.

All control and limit channels are connected to the complementary output stage via an EXCLUSIVE OR gate, so that only one main channel, voltage or current, is in control of the BOP output at any one time. The BOP output can be programmed over its full output range by a ± 10 volt signal applied to either one of the inputs to the voltage or the current channel. The limit control channels can be controlled either locally through the front panel trimpots or remotely by a 0 to +10 volt signal applied to their respective inputs: the lower value (either local or remote) will be active. Two uncommitted preamplifiers, with both inverting and non-inverting inputs available at the Rear Programming Connector, can scale any programming source to the required internal control levels of the main channel. Zero adjustments for both preamplifiers are provided.

If the a BIT card is installed, and the BOP output is being controlled digitally, it can only control the main channel and its complementary limit channel, with identical values for positive and negative limits. The lower limit value between the front panel setting and the digital setting will be active.

The BOP is a fast programmable power supply. The dynamic specifications, given in Table 1-3, are valid for resistive loads.

1.4 ELECTRICAL SPECIFICATIONS, GENERAL

See Table 1-1 for general specifications

TABLE 1-1. GENERAL SPECIFICATIONS

SPECIFICATION	RATING/DESCRIPTION ⁽¹⁾	CONDITION/COMMENT
Input Voltage (Nominal)	104/ 115/ 208/ 230Vrms	Tolerance: ±9% Internal setting for the nominal input
Input Brown-out Voltage	Max 103.5Vrms	@ 115V/60Hz, Sourcing nominal output power
Input Frequency (Nominal)	50/ 60Hz	Tolerance:± 3Hz
Input Specifications	Input current, input power (active), power factor and efficiency differ by model.	See Table 1-2.
Input Leakage Current	50uArms	@ 115V/ 60Hz, Sourcing nominal output power
Insulation Coordination	Installation Cat. 2 Over-voltage Cat. 2 Pollution Degree 2	Maximum 500V DC or PK between COM output terminal and chassis-ground
Type Of Stabilizer	Voltage-Current, 4-quadrant	
Topology	Linear, Half Bridge	Class AB
Output Voltage	0 to ±E _O max (Volts DC or peak)	See Table 1-3 for E _O max values.
Output Current	0 to ±I _O max (Amperes DC or peak)	See Table 1-3 for I _O max values.
Output Power (Nominal)		For long term operation in sink, reduce the complementary limit settings to half of nominal. See Table 1-3 for nominal output power values.
Source Mode	E _O max x I _O max (Watts DC or peak)	
Sink Mode	(E _O max x I _O max)/2 (Watts DC or peak) ⁽²⁾	
Output OFF/disabled level		The output OFF level can be calibrated using trim pots accessible from the top cover (see PAR. 4.3.9).
Voltage Mode	0V ±(0.01%)(E _O max)V	
Current Mode	0A ±(0.01%)(I _O max)A	
Voltage, Analog Programming (V.Mode)		
DC Transfer Factor	(-E _O max/10) V/V (default), it can be changed thru rear programming connector to (+E _O max/10) V/V	Install components on rear programming connector for a different preamp transfer factor.
Linearity	0.005% of E _O max	Use rear programming connector to configure non-inverting operation.
FS Tolerance	0.2% of E _O max with the default preamplifier's network, or 0.02% when using external 0.01% matched pair resistors for the preamplifier	There is no internal calibration for the transfer factor in voltage mode.
Output Impedance	Model dependent	See Table 1-3 for default d-c transfer factor and output impedance values.
<p>(1) Specifications listed for ambient temperature = 20°C unless otherwise specified. (2) Output power - Sink mode for BOP 5-20 = E_Omax x I_Omax (DC or peak).</p>		

TABLE 1-1. GENERAL SPECIFICATIONS

SPECIFICATION	RATING/DESCRIPTION ⁽¹⁾	CONDITION/COMMENT
Voltage Static Specifications (V.mode)		
Source effect	0.001% of E_{Omax}	Input voltage = nominal $\pm 9\%$
Load effect	0.002% of E_{Omax}	No load to $(1.05 \times E_{Omax})/I_{Omax}$
Time effect (8h)	0.01% of E_{Omax}	After 30 minutes of conditioning
Temp. coefficient	0.01% of $E_{Omax}/^{\circ}C$	Averaged for the operating temperature range.
Ripple & noise (rms)	the greater of 0.01% of E_{Omax} or 3mV	
Current, Analog Programming (C.mode)		
DC Transfer Factor	$(-I_{Omax}/10)A/V$ (default), it can be changed thru rear programming connector to $(+I_{Omax}/10)A/V$	Install components on rear programming connector for a different preamp transfer factor. Use rear programming connector to configure non-inverting operation.
Linearity	0.02% of I_{Omax}	
FS Tolerance	0.02% of I_{Omax}	Transfer factor in current mode has an internal calibration.
Output Impedance	Model dependent	See Table 1-3 for d-c current transfer factor and output impedance values.
Current Static Specifications (C.mode)		
Source effect	0.005% of I_{Omax}	Input voltage = nominal $\pm 9\%$
Load effect	0.05% of I_{Omax}	Short circuit to $(0.95 \times E_{Omax})/I_{Omax}$
Time effect (8h)	0.02% of I_{Omax}	After 30 minutes of conditioning
Temp. coefficient	0.02% of $I_{Omax}/^{\circ}C$	Averaged for the operating temperature range.
Ripple & noise (rms)	0.03% of I_{Omax}	
Local Output Control/DC Bias		
Range	Zero to $\pm E_{Omax}$ (Voltage mode) or $\pm I_{Omax}$ output (Current mode)	Independent controls for voltage in V.mode and for current in C.mode. To be sure that $\pm E_{Omax}$ and $\pm I_{Omax}$ values can be attained, the bias controls reach approximately 105% of nominal values.
Type	10-turns front panel potentiometers	
Analog Programming Input		
Type	Inverting (default) or Non-inverting	Independent inputs for voltage and current control. Use rear programming connector to change type.
Voltage range	0 to $\pm 10V$ (default)	Referenced to COMS
Impedance	10K Ohms (default)	
Location	Separate jacks for voltage and current on front panel, or use wiring on rear programming connector	

TABLE 1-1. GENERAL SPECIFICATIONS

SPECIFICATION	RATING/DESCRIPTION ⁽¹⁾	CONDITION/COMMENT	
Output ON-OFF (enable-disable) Control	Non-isolated 15V-CMOS signal at rear programming connector (see Table 1-5, pin 21 for details)		
	Isolated TTL or 15V-CMOS signal (see Table 1-5, pin 50 for details)	If not used for on-off control, the non-isolated controlling input (see Table 1-5, pin 21 for details) can be used to establish the enable-disable logic of the isolated input.	
	Digital remote commands via active (optional) BIT card (see PAR. 1.2.4).		
Voltage Mode/Current Mode Control	Front panel switch		
	Remote TTL non-isolated signal at rear programming connector (see Table 1-5, pin 30 for details)	Pin 30 at the rear programming connector can be used if the digital card is not present; however the remote-local input at pin 35 must be set to remote.	
	Digital remote commands via active (optional) BIT card (see PAR. 1.2.4).		
Digital Programming	Optional BIT 4886 card, for GPIB or RS232 control, or BIT 802E card, for LAN control	Both BIT 4886 and BIT 802E cards able to set and monitor DC values only (see PAR 1.2.4).	
Calibration	Using trim-pots for standard (analog) units. Digital calibration with the digital (BIT card) control.		
Dynamic Specs (V.mode and C mode)	Model dependent	See Table 1-4	
Special Dynamic Configurations	Main loop bandwidth reduction	Possible, with changes at rear programming connector, for voltage and/or current	
	Optimized for inductive loads	Models with L suffix	
	Optimized for capacitive loads	Models with C suffix	
Voltage/Current Limits (Pos & Neg)	Local/ front panel adjustment. range	0.2 to 110% ⁽³⁾ of nominal output, using front panel single turn pots	
	Analog-remote adjustment range	0.2 to 110% of nominal output, using 0V to +10V programming. voltage applied to rear programming connector,	Only the lowest of local or remote analog limit values is active. When digital control (BIT card) is installed, analog remote limit values are disabled.
	Digital-remote adjustment range	0.2 to 110% of nominal output, using digital remote commands via active (optional) BIT card (see PAR. 1.2.4).	Only the lowest of local or remote digital limit values is active.
(3) For BOP 5-20D: 1 to 110% of nominal output voltage for voltage limit and 0.5 to 110% of nominal output current for current limit.			

TABLE 1-1. GENERAL SPECIFICATIONS

SPECIFICATION	RATING/DESCRIPTION ⁽¹⁾	CONDITION/COMMENT
Analog Readback For Voltage and Current	Range	0 to ±10V, for 0 to ± nominal output
	Full Scale tolerance	0.02% of nominal monitoring output (10V)
	Accuracy	0.1% of nominal monitoring output (10V)
	Max current	1mA
Kelvin Connection (remote error sensing)	Possible, with max 0.5V/ wire ⁽⁴⁾	
Local Output Monitoring	Type	Analog meters (M suffix models) Digital Panel Meters (DPM, D suffix models) for output voltage and current
	Accuracy	Analog meter: 2% DPM: ±(0.2% of full scale +2 counts) ⁽⁵⁾
Reference Voltages/Bias Sources	Value	+10V, -10V
	Tolerance	±1mV
	Load Current	4mA max.
	Source Effect	0.0005%
	Load Effect	0.0005%
	Time Effect	0.005%
	Temp. Coefficient	0.005%/°C
Front Panel Lights	VOLTAGE MODE	Lit when in Voltage Mode
	CURRENT MODE	Lit when in Current Mode
	VOLTAGE LIMIT	Lit when in Voltage Limit
	CURRENT LIMIT	Lit when in Current Limit
	REMOTE (W/ DIG ON)/OUT ON (W/DIG OFF)	Dual function indicator a) When digital programming (BIT card) installed and active: lit when in REMOTE mode, off when in LOCAL mode b) When digital programming either not installed or inactive: lit to show OUTPUT on, off to show OUTPUT off

(4) For BOP 5-20D and BOP 5-30D: 0.25V/wire max.

(5) E.g, for a unit rated at 100V, at rated output the digital voltmeter reads $100.0V \pm (0.002 \times 100 + 0.2)V = 100.0V \pm 0.4V$. For a unit rated at 20A, at rated output the digital ammeter reads $20.0A \pm (0.002 \times 20 + 0.2)A = 20.0A \pm 0.2A$.

TABLE 1-1. GENERAL SPECIFICATIONS

SPECIFICATION		RATING/DESCRIPTION ⁽¹⁾	CONDITION/COMMENT
Flag Signals NOTE: All flags available at rear programming connector (see Table 1-5)	Voltage Mode	Active in when in voltage mode	TTL signal, active "L", non-isolated
	Current Mode	Active in when in Current mode	TTL signal, active "L", non-isolated
	Voltage Limit	Active in when in Voltage limit	TTL signal, active "L", non-isolated
	Current Limit	Active in when in Current limit	TTL signal, active "L", non-isolated
	Local-remote	If digital programming (optional BIT card) installed, active when in digital remote operation.	TTL signal, active "L" for digital remote, non-isolated
	Output On-off	Output on-off	Optocoupler transistor, saturated for output on, isolated. See Table 1-5, pin 46 for details.
Front and rear panel controls, indicators and terminals,		Front Panel: See Figure 2-1 and Table 2-1. Rear Panel: See Figure 2-2 and Table 2-2.	
Series Or Parallel Configurations (identical units only)	Type of connection	Master-Slave	
	Implementation	Configured by external wiring at rear programming connector	
	Number of units	3 units (max.)	Contact factory if configurations using more than 3 units in series or parallel are needed.
Protections		(a) Input overcurrent, with 110% threshold (b) Heat-Sink overtemperature (c) Multiple units interlock (d) Input power loss	Trips Input circuit breaker. Tripping of the circuit breaker for input power loss can be disabled by a modification to the rear programming connector (see PAR. 3.6.2).
Temperature	Operating	0 to +55° C	
	Storage	-40 to +85° C	
Humidity		0 to 95% RH	Non-condensing
Shock		20g/11ms/50% half sine	Non-operating
Vibration	5-10Hz	10mm, double amplitude	Non-operating
	10-55Hz	2g	
Altitude		Sea level to 10,000ft	For operating temperature range
Cooling	Type	BOP 100W, 200W (except BOP 200-1): 1 fan BOP 400W and BOP 200-1: 2 fans	Minimum 1U between stacked units.
	Air Flow	Front to rear	
	Air Intake	top, bottom, side	
Dimensions	BOP 100W, 200W ⁽⁶⁾	5.22" H x 12.53" W x 19" D (132.6mm H x x318.3mm W x 484.6.8mm D)	3/4 Rack
	BOP 5-20D, BOP 5-30D, 200-1 and all 400W models	5.22" H x 19" W x 22" D (132.6mm H x x482.6mm W x 558.8mm D)	Full Rack
Weight	BOP 100W, 200W ⁽⁷⁾	48 lbs (21.8 Kg)	Unpacked
	BOP 200-1 and all 400W models	75 lbs (34.02 Kg)	
(6) Except BOP 5-20D, 5-30D and BOP 200-1. (7) Except BOP 200-1.			

TABLE 1-1. GENERAL SPECIFICATIONS

SPECIFICATION		RATING/DESCRIPTION ⁽¹⁾	CONDITION/COMMENT
Connections	Source power	3-pin IEC connector	
	Load connections,	Front: 5-jacks; Rear: 6-pin terminal block	
	Grounding, GND network	Front: 5-jacks; Rear: 6-pin terminal block	
	Analog control	50-pin rear programming connector	
	Digital control	BIT 4886 card: 24-pin GPIB connector BIT 802E card: 8-pin Ethernet (LAN) connector	

TABLE 1-2. INPUT SPECIFICATIONS

MODEL ⁽¹⁾	INPUT CURRENT ⁽²⁾ (A)	ACTIVE INPUT POWER ⁽²⁾ (W)	POWER FACTOR ⁽²⁾	EFFICIENCY ⁽²⁾ (%)
100 WATTS				
BOP 5-20	4.7	460	0.84	22
BOP 20-5	2.9	270	0.81	37
BOP 50-2	2.9	270	0.81	37
BOP 100-1	2.9	270	0.81	37
200 WATTS				
BOP 5-30	5.2	570	0.84	26
BOP 20-10	5.5	540	0.85	37
BOP 36-6	5.1	490	0.84	44
BOP 50-4	4.8	450	0.82	44
BOP 72-3	5.1	470	0.80	46
BOP 100-2	4.8	450	0.82	44
BOP200-1	5.5	450	0.71	44
400 WATTS				
BOP 20-20	11.2	1115	0.87	36
BOP 36-12	10.7	1050	0.85	41
BOP 50-8	9.6	1000	0.91	40
BOP 72-6	10.9	1085	0.87	40
BOP 100-4	9.2	885	0.84	45
(1) Models with analog meters include suffix M; models with digital meters include suffix D.				
(2) Specifications listed are for Input @ 115V, 60Hz sourcing nominal power.				

TABLE 1-3. OUTPUT RANGES, TRANSFER FACTOR AND OUTPUT IMPEDANCE

MODEL ⁽¹⁾	DC OR PEAK OUTPUT RANGES		DC OR PEAK OUTPUT POWER		d-c CLOSED LOOP GAIN		OUTPUT IMPEDANCE ⁽²⁾			
	E _O MAX. V	I _O MAX A	SOURCE W	SINK W	VOLTAGE CHANNEL	CURRENT CHANNEL	VOLTAGE MODE		CURRENT MODE	
					G _V (V/V)	G _I (A/V)	SERIES R mΩ	SERIES L mH	SHUNT R kΩ	SHUNT C μF
100 WATTS										
BOP 5-20	0 to ±5	0 to ±20	100	100	0.5	2.0	0.01	0.004	5.0	0.3
BOP 20-5	0 to ±20	0 to ±5	100	50	2.0	0.5	0.08	0.02	40	0.05
BOP 50-2	0 to ±50	0 to ±2	100	50	5.0	0.2	0.5	0.1	50	0.05
BOP 100-1	0 to ±100	0 to ±1	100	50	10.0	0.1	2.0	0.2	100	0.05
200 WATTS										
BOP 5-30	0 to ±5	0 to ±30	150	150	0.5	3.0	0.01	0.004	5.0	0.5
BOP 20-10	0 to ±20	0 to ±10	200	100	2.0	1.0	0.04	0.05	20	0.1
BOP 36-6	0 to ±36	0 to ±6	216	108	3.6	0.6	0.12	0.05	36	0.1
BOP 50-4	0 to ±50	0 to ±4	200	100	5.0	0.4	0.25	0.1	50	0.05
BOP 72-3	0 to ±72	0 to ±3	216	108	7.2	0.3	0.48	0.2	72	0.05
BOP 100-2	0 to ±100	0 to ±2	200	100	10.0	0.2	1.0	0.2	100	0.05
BOP200-1	0 to ±200	0 to ±1	200	100	20.0	0.1	4.0	1.2	200	0.03
400 WATTS										
BOP 20-20	0 to ±20	0 to ±20	400	200	200	2.0	0.02	0.05	20	0.2
BOP 36-12	0 to ±36	0 to ±12	432	216	3.6	1.2	0.06	0.05	36	0.2
BOP 50-8	0 to ±50	0 to ±8	400	200	5.0	0.8	0.125	0.1	50	0.15
BOP 72-6	0 to ±72	0 to ±6	432	216	7.2	0.6	0.24	0.2	72	0.1
BOP 100-4	0 to ±100	0 to ±4	400	200	10.0	0.4	0.5	0.2	100	0.1
<p>(1) Models with analog meters include suffix M; models with digital meters include suffix D.</p> <p>(2) Output impedance is for models with either M or D suffix. For models with L or C options (ML, MC, DL or DC suffix) see applicable Modification Sheets available from Kepco's website at http://www.kepcopower.com/support/opmanls.htm#bop</p>										

TABLE 1-4. OUTPUT DYNAMIC SPECIFICATIONS

MODEL (1) (7)	3dB BANDWIDTH (2) (3)		RISE & FALL TIME (2) (4) 10%-90% µsec		SLEW RATE (2) (5) (average)		RECOVERY AT STEP LOAD (2) (6) µsec	
	KHz		Mode		Mode		Mode	
	V	I	V	I	V V/µsec	I A/µsec	V	I
100 WATTS								
BOP 5-20	22	11	17	32	0.47	1.0	10	40
BOP 20-5	18	12	20	30	1.6	0.27	25	10
BOP 50-2	18	12	20	35	4.0	0.11	25	10
BOP 100-1	18	11	22	25	9.4	0.07	40	25
200 WATTS								
BOP 5-30	12	9	30	40	0.27	1.2	50	80
BOP 20-10	18	10	20	40	1.6	0.27	80	20
BOP 36-6	16	13	25	30	2.5	0.61	50	35
BOP 50-4	23	14	15	25	5.7	0.26	40	30
BOP 72-3	20	15	18	26	6.4	0.18	30	30
BOP 100-2	22	15	18	26	8.9	0.12	30	30
BOP200-1	4.0	2.5	110	150	2.9	0.01	150	120
400 WATTS								
BOP 20-20	9.5	10	35	35	0.9	0.91	100	75
BOP 36-12	20	10	16	35	3.6	0.64	50	30
BOP 50-8	24	10	14	35	5.7	0.37	40	30
BOP 72-6	19	9.5	18	40	6.4	0.24	50	20
BOP 100-4	18	14	22	30	7.3	0.21	40	30
<p>(1) Models with analog meters include suffix M; models with digital meters include suffix D.</p> <p>(2) Specifications listed are for Input @ 115V, 60Hz.</p> <p>(3) Represents 3-dB bandwidth for large sine signal for nominal resistive load/peak output voltage value @ 50Hz, equal to E_Omax in V mode and for short circuit/peak output current @ 50Hz, equal to I_Omax in I mode.</p> <p>(4) Represents the response timing of the pulsed output (@ 100Hz) for nominal resistive load/between ±E_Omax in V mode and for short circuit/between ± I_Omax in I mode.</p> <p>(5) Defined as the ratio between (1.6)(E_Omax) or (1.6)(I_Omax) and the corresponding rise/fall time for the same conditions described in Note (4) above.</p> <p>(6) Represents the 10-90% timing of a changing output when the load is switched between no load and nominal resistive load in V mode and between short circuit and nominal resistive load in I mode.</p> <p>(7) Dynamic specifications are for models with either M or D suffix. For models with L or C options (ML, MC, DL or DC suffix) see applicable Modification Sheets available from Kepco's website at http://www.kepcopower.com/support/opmanis.htm#bop</p>								

1.5 MISCELLANEOUS FEATURES

1.5.1 OUTPUT RANGE

The BOP can be locally (front panel) adjusted, or remotely programmed, from (-)100% to (+)100% of its specified d-c voltage and current range. The Class AB bipolar output stage permits operation as either a *source* or a *sink*. (See Figure 1-2).

NOTE: The BOP is operating as a *source* if the direction of its output voltage is the same as the direction of its output current. The BOP is operating as a *sink* if the direction of its output voltage is opposite that of its output current. An illustrative case is shown in Figure 1-3, where the BOP is programmed to deliver a sine wave output and where the load produces a phase shift between the output voltage and current.

1.5.2 REAR PROGRAMMING FEATURES

The external Rear Programming Connector (See Table 2-2, Items 22 and 23 and Figure 3-30), is a 50-pin edge connector, providing access to all circuit features. The BOP is delivered with one (1) PC 15 connector, which is prewired with jumpers for local (front-panel) operation. Spare connectors may be purchased from Kepco under the model number PC 12 for the unwired connector and PC 15 for a connector prewired for local operation. The functions of the Rear Programming Connector terminals are listed below in Table 1-5.

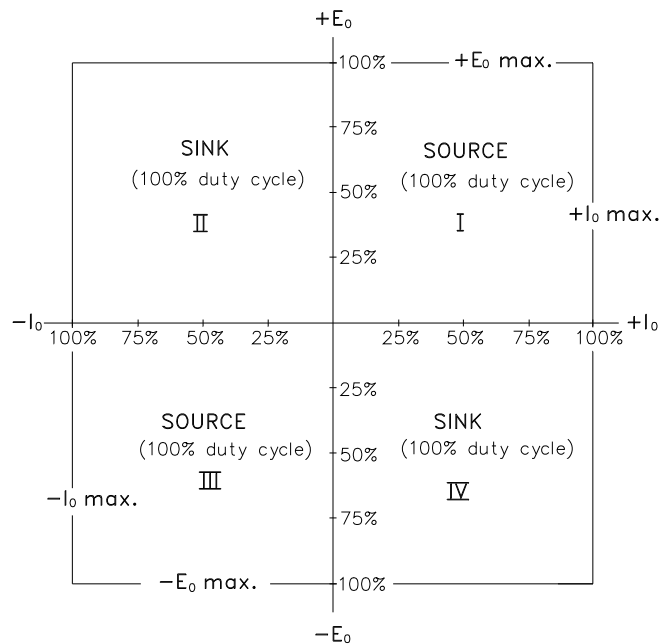

3043872

FIGURE 1-2. BOP OUTPUT CHARACTERISTIC

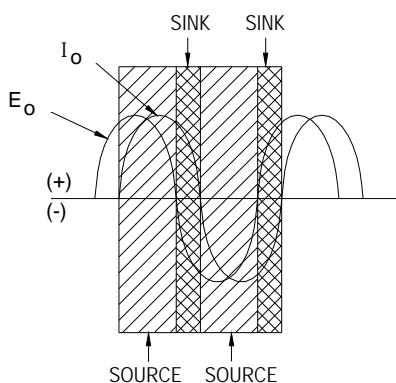

3043440

FIGURE 1-3. BOP OUTPUT WAVEFORMS WITH PHASE SHIFT

TABLE 1-5. REAR PROGRAMMING CONNECTOR TERMINAL FUNCTIONS

TERMINAL (Figure 3.2.4)	FUNCTION	DESCRIPTION
1	Current Limit Reference	Refer to PAR. 3.3.2
3	Voltage Limit Reference	Refer to PAR. 3.3.4
15 13 2 4	Preamp "B" 	Refer to PAR. 3.5 for example.
11 9 5 7	Preamp "A" 	Refer to PAR. 3.4.1 for example. NOTE: A1R23 = 2.5K for 5V models, 10K for all others
6	+E _O Limit Input	Refer to PAR. 3.3.4
8	+I _O Limit Input	Refer to PAR. 3.3.2
32	-E _O Limit Input	Refer to PAR. 3.3.4
34	-I _O Limit Input	Refer to PAR. 3.3.2
10	Current Monitoring	Analog output voltage (0 to ±10V, 1 mA max) proportional to the prevailing BOP output current for remote metering or monitoring.
20	Voltage Monitoring	Analog output voltage (0 to ±10V, 1 mA max) proportional to the prevailing BOP output voltage.
12, 14	Voltage Mode Compensating Terminals	Refer to PAR. 1.5.4
16, 18	Current Mode Compensating Terminals	Refer to PAR. 1.5.4
17	Voltage Comparison Amp Input	Analog input voltage of 0 to ±10V will produce 0 to ± full output voltage with unit set in voltage mode.

TABLE 1-5. REAR PROGRAMMING CONNECTOR TERMINAL FUNCTIONS (CONTINUED)

TERMINAL (Figure 3.2.4)	FUNCTION	DESCRIPTION
19	Current Comparison Amp Input	Analog input voltage of 0 to $\pm 10V$ will produce 0 to \pm full output current with unit set in current mode.
21	On-off Controlling Logic for the isolated on-off port, or Non-isolated on-off control	Establishes whether TTL "1" or "0" applied to pin 50, referenced to pin 48 turns the output on or off. <ul style="list-style-type: none"> No signal (default) or "1" (15V CMOS): "0" = ON, "1" = OFF "0" or short to pin 23: "1" = ON, "0" = OFF <p>NOTE: Pin 21 has a 15K Ohm pull-up resistor connected to the internal +15V bus.</p> <p>If no signal is applied between pin 50 and pin 48, pin 21 can be used as a non-isolated on-off control as follows:</p> <ul style="list-style-type: none"> If Remote mode is not active (pin 35 not set to TTL "0"): <ul style="list-style-type: none"> no signal or "1" (15V CMOS) = output ON "0" or short to pin 23 = output OFF If Remote mode is active (pin 35 set to TTL "0"): <ul style="list-style-type: none"> no signal or "1" (15V CMOS) = output OFF "0" or short to pin 23 = output ON
22	-10V Reference Voltage 4mA Max	Refer to PAR. 3.4.1 for examples.
28	+10V Reference Voltage 4mA Max	Refer to PAR. 3.4.1 for examples.
23, 25, 27, 29, 31, 33	Sensing Common	
24	Circuit Breaker Control	Refer to PAR, 3.6.2
26, 36	Turn-off Signal Output	Refer to PAR, 3.6.2
30	Voltage Mode/Current Mode control	Used to set either voltage mode or current mode (disables front panel MODE switch). For use only if a BIT card is not installed. Remote mode (pin 35) must be active to enable pin 30 and the output must be set to ON by connecting pin 21 to sensing common, pin 23. This disables the isolated Output ON-OFF Control at pin 50 and the isolated Output ON-OFF flag at pin 46 and allows pin 21 to be used as non-isolated Output ON-OFF control (see pin 21 for Remote mode is active). <ul style="list-style-type: none"> Voltage mode = open or TTL "1" Current mode = short (referenced to sensing common, pin 23) or TTL "0"
35	Local/Remote control	Used to set either local or remote mode For use only if a BIT card is not installed. Pin 35 must be set to Remote for pin 30 to be active. <ul style="list-style-type: none"> Local mode = open or TTL "1" Remote mode = short (referenced to sensing common, pin 23) or TTL "0"
37	+5V	Built-in TTL Logic supply, 5V @ 40mA max.
38	I_O Limit Flag	Refer to PAR. 3.7
39	E_O Limit Flag	Refer to PAR. 3.7
40	E_O Mode Flag	Refer to PAR. 3.7
42	I_O Mode Flag	Refer to PAR. 3.7
41	Non-isolated Turn-off Signal Input	Refer to PAR, 3.6.2
43, 44, 45	Not Used.	

TABLE 1-5. REAR PROGRAMMING CONNECTOR TERMINAL FUNCTIONS (CONTINUED)

TERMINAL (Figure 3.2.4)	FUNCTION	DESCRIPTION
46	/ON-OFF_FLAG	<p>Flags whether output set to ON or OFF. This isolated flag signal is the open collector of an optocoupler-transistor, with the emitter connected to pin 48. Optocoupler transistor is saturated when the output is ON (enabled). Current through the transistor should not exceed 1.6mA and supply voltage should not exceed 24V.</p> <ul style="list-style-type: none"> OFF level: determined by $(V_{ext}) - (R_{ext})(I_{coff})$ where: V_{ext} = External positive voltage. $R_{ext} = V_{ext}/1.6mA$ (External current-limiting resistor). $I_{coff} = 0.0001mA$ (optocoupler transistor maximum dark current). <p>The flag's rise time for either voltage mode with no load, or current mode with short circuit, is within 150μS max.</p> <ul style="list-style-type: none"> ON level: +0.4V max. for 1.6mA current. The flag's fall time for either voltage mode with no load, or current mode with short circuit, is within 150μS max. <p>NOTE This signal is disabled if the unit is set in current mode using pins 30 and 35.</p>
47, 49	Optically Isolated Turn-off Signal Input	Refer to PAR. 3.6.2.
48	ISO_GND	Return for ON-OFF_CTRL and for /ON-OFF_FLAG signals.
50	ON-OFF_CTRL	<p>Optically isolated signal that controls output to be either ON (enabled) or OFF (disabled). The logic of the control is established by pin 21 (see above).</p> <p>If pin 21 is not used (default status), the control levels for pin 50 are defined as follows:</p> <ul style="list-style-type: none"> ON control (default): 0V to 0.4V or no connection (open circuit) at pin 50, referenced to pin 48. Turns ON within 100μS max (between 10% point of controlling signal and a) 10% point of output voltage for voltage mode with no load or b) 10% point of output current for current mode with short circuit). OFF control (default): 3.5V to 24V d-c at pin 50 referenced to pin 48; input current is 1mA \pm0.3mA. Turns OFF within 100μS max (between 90% point of controlling signal and a) 90% point of output voltage for voltage mode with no load or b) 90% point of output current for current mode with short circuit). <p>If the BOP has a BIT card installed and active, the ON-OFF_CTRL and /ON-OFF_FLAG (pin 46) are disabled to allow the BIT card to control output on-off and monitor output on-off status.</p> <p>NOTE This signal is disabled if the unit is set in current mode using pins 30 and 35.</p>

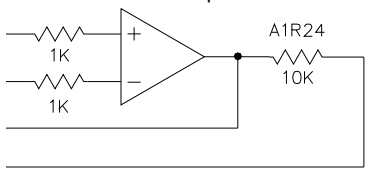
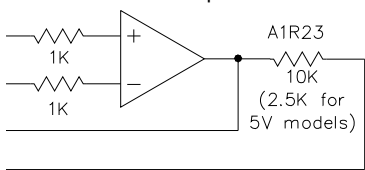
1.5.3 REMOTE ON-OFF FEATURE

The output of the unit can be turned ON (enabled) or turned OFF (disabled) from the rear panel isolated ON-OFF signal applied to pin 50 referenced to pin 48 of the rear programming connector or by a non-isolated ON-OFF signal applied to pin 21 referenced to pin 23 (see Table 1-5).

1.5.4 LOAD REACTANCE

1.5.4.1 DRIVING AN INDUCTIVE LOAD IN CURRENT MODE

BOP power supplies with option L (L suffix) are optimized for driving large inductor loads. Factory test were performed with loads up to 1H, however higher values are possible.

For basic units (without L suffix) when driving inductive loads higher than 0.5mH, the system may become unstable. There are two means of eliminating oscillation in the current loop operating with moderate inductive loads and moderate voltage and current:

1. Add capacitance in parallel with the output (inductive load). The value of capacitor can be from 0.1 μF to 1.0 μF depending on the value of the load inductance.
2. Add a series-connected resistor-capacitor network in parallel with the BOP output/inductive load. The value of resistor should be in the range of 100 to 500 Ohms and the value of capacitor should be 0.1 μF to 0.5 μF , depending on the load inductance value.

Both options are recommended when the BOP is used with very low frequency output into inductive loads.



CAUTION: When driving heavy inductive loads with high currents, it is possible for the BOP and the load to be damaged by an A-C input power loss which prevents the load's stored energy from being dissipated inside the BOP. To avoid possible damage from the inductance kick-back voltage observe the following:

- Use UPS to supply the BOP.
- Set BOP output current and/or voltage to zero and turn off the BOP after the output current actually reaches a zero value.
- Use properly rated (voltage and current) bipolar transorbs or a properly rated bipolar crowbar element connected directly at the output of the BOP. An alternative is a Normally-Closed Contactor connected across the output of the BOP that will be controlled open during normal operation. The coil of the contactor will be supplied from the same input power source as the BOP. These options may also be combined.

For both basic (without L suffix) and L suffix units, if the system becomes unstable at the cross-over between voltage limit mode and current mode when driving an inductive load, the power supply can be further optimized by reducing the current loop bandwidth. This can be accomplished by connecting a ceramic capacitor across pins 16 and 18 of the Rear Programming Connector (see Figure 3-30 and Table 1-5). The value of the capacitor is correlated to the load's inductance. A value in the range of 0.0022 μF to 0.1 μF is recommended.

1.5.4.2 DRIVING A CAPACITIVE LOAD IN VOLTAGE MODE

BOP power supplies with option C (C suffix) are optimized for driving large capacitive loads (e.g., solar panels and solar cells). Factory test were performed with loads up to 10mF, however higher values are possible.

For basic units (without C suffix) the system can become unstable when driving a capacitive load higher than 0.2 μ F in voltage mode. Install an external ceramic capacitor rated for 50V across pins 12 and 14 of the rear programming connector for stable operation. This capacitor will reduce the voltage loop bandwidth. The value of the capacitor is correlated to the load's capacitance. A value in the range of 0.0047 μ F to 0.47 μ F is recommended. This method can also be used for C suffix models if the system becomes unstable at the crossover between voltage mode and current mode.

1.5.5 REMOTE TURN-OFF

Remote turn-off of the BOP, equivalent to tripping the front panel ON-OFF circuit breaker to OFF, can be accomplished by a contact closure, or by an optically isolated signal (see PAR. 3.6.2).

1.5.6 CIRCUIT BREAKER SHUTDOWN PREVENTION (AT POWER LOSS) CIRCUIT

See PAR. 3.6.2.

1.5.7 REFERENCES

Two reference/bias sources (± 10 V at 4 mA max.) are provided for control and biasing purposes. These reference sources are available at the rear programming connector (with reference to the "COMMON" terminal).

1.5.8 SERIES OR PARALLEL OPERATION

See PAR. 3.6

1.5.9 VOLTAGE CONTROL CHANNEL

The Bipolar Voltage Amplifier, with a fixed gain (See Table 1-3 for gain value) is connected via the MODE switch to the Voltage Preamp (see Figure 3-2). If the VOLTAGE CONTROL switch is on, the BOP output voltage can be locally controlled by means of the (front panel) (\pm) 10 volts bias source, from (-) 100% (through zero) to (+) 100% of the rated value. The Voltage Preamp has a Zero trimpot and all its terminals are available at the Rear Programming Connector for remote control of the output voltage. A Zero E_O offset trimpot is provided for calibration of the voltage loop. Refer to applicable Service Manual for calibration of trimpots. Control methods are described in PAR. 3.4.

1.5.10 EXTERNAL VOLTAGE MONITOR

Use signal E_O Monitor Output at pin 20 of the rear programming connector (see Figure 3-30) for external voltage monitoring (see PAR. 3.2.7 for details).

1.5.11 EXTERNAL CURRENT MONITOR

Use signal I_O Sensing Output at pin 10 of the rear programming connector (see Figure 4-5) for external current monitoring (see PAR. 3.2.8 for details).

1.5.12 MODE SWITCH

The BOP is equipped with a front panel-mounted MODE switch, which selects bipolar voltage or bipolar current control. See paragraph 1.5.16 for remote MODE control.

1.5.13 CURRENT CONTROL CHANNEL

The Bipolar Current Amplifier, with a fixed gain (See Table 1-3 for gain value) is connected via the MODE switch to the Current Preamplifier (see Figure 3-4). If the CURRENT CONTROL switch is on, the BOP output current can be locally controlled by means of the (front panel) (\pm) 10 volts bias source, from ($-$) 100% (through zero) to ($+$) 100% of the rated value. The Current Preamplifier is provided with a Zero trimpot and all its terminals are available at the Rear Programming Connector for remote control of the output current. The current control loop has trim-pots for current sensing amplifier Zero, and for the complete current loop and full scale current calibration. Refer to applicable Service Manual for calibration of trim-pots. Control methods are described in PAR. 3.5.

1.5.14 BOUNDING

The BOP has four output voltage/current limiting circuits ($-$) E_O Limit, ($+$) E_O Limit, ($-$) I_O Limit and ($+$) I_O Limit for overvoltage/overcurrent protection in either operating mode (refer to Figures 3-5 and 3-3). All limiting circuits can be screwdriver adjusted by means of four front panel controls. In addition, all four limits can be remotely controlled by means of 0 to 10 volt d-c control voltages. The four limits may be remotely programmed independently, or the (\pm) voltage and (\pm) current limits can be controlled in pairs. The lower limit control value, between the front panel setting and the remote control signal, will be active

The four boundary quantities, (\pm) E_O max. Limit and (\pm) I_O max. Limit as applied to the Limit Channel, are actually about 10% greater than the rated values E_O max. and I_O max. for each BOP model. See Table 1-1 for minimum limit values. To avoid uncertainty related to zero reference for multiple output control loops the minimum limit values are not zero. See Figure 1-4 for a graphic representation of boundaries and limits.

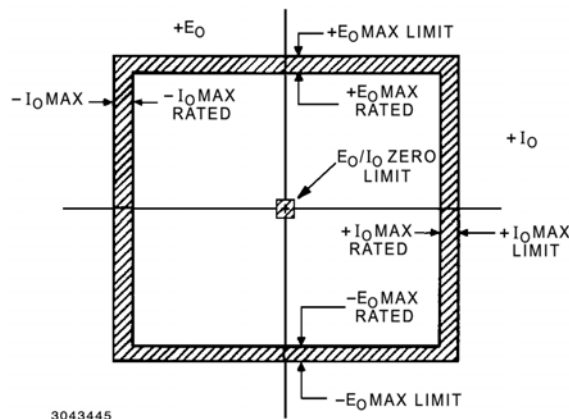

FIGURE 1-4. BOUNDARIES AND LIMITS

1.5.15 MODE LIGHTS

Four (4) front panel (LED type) indicator lamps monitor the prevailing operating mode of the BOP. For each operating condition (Voltage Mode, Current Mode, $\pm E_o$ Limit, $\pm I_o$ Limit) the corresponding indicator lamp energizes. Simultaneous TTL flags are available on the Rear Programming Connector (see PAR. 3.7).

1.5.16 REMOTE (W/ DIG ON) / OUT ON (W/ DIG OFF) LED

This is a dual function indicator, depending on whether a digital BIT card is active. If a BIT card is controlling the output (DIG ON = digital card active), the indicator functions as a REMOTE digital control indicator and is lit when the unit is under digital remote control. If a BIT card is either not installed or not active (DIG OFF), the indicator functions as an OUTPUT ON indicator and is lit for output on (enabled) and off for output off (disabled).

1.5.17 STANDARDS

BOP models are designed and tested in accordance with NEMA Standard for Stabilized Power Supplies, d-c output, Publication No. PY-1.1972.

1.6 MECHANICAL SPECIFICATIONS

See Mechanical Outline Drawing, Figure 1-5 for dimensions and finish of 3/4-rack models and Figure 1-6 for full rack models.

1.7 EQUIPMENT SUPPLIED

Equipment supplied is listed in Table 1-6.

TABLE 1-6. EQUIPMENT SUPPLIED

ITEM	PART NUMBER	QUANTITY	
Rear Programming Connector (Local Control) - 50-terminal printed circuit connector for all rear programming connections and flag-signal outputs, wired for local (front panel) control of the BOP output.	PC 15	1	
Power Cord, IEC connection to standard 115 VAC (USA),	118-0557	1	
Mounting Flanges - for installation of the BOP into a standard (19 inch) equipment rack	Right	128-0927	1
	Left.	128-0926	1
Local Sensing Links at front panel	172-0122	2	

1.8 ACCESSORIES

Accessories (not supplied) are listed in Table 1-7.

TABLE 1-7. ACCESSORIES - NOT SUPPLIED

ITEM	FUNCTION	KEPCO PART NUMBER
Rear Programming Connector, Unwired	50-terminal printed circuit connector, unwired, for access to all rear programming connections and flag-signal outputs.	PC 12
Slides	Ease of access to adjustments through top cover	110 QD (Jonathan)
BIT 4886 Interface Card	Allows remote programming of BOP via GPIB or RS 232 interface using IEEE 488 and SCPI commands and queries.	BIT 4886
BIT 802E Interface Card	Allows remote programming of BOP via Ethernet /LAN using web pages.	BIT 802E
Side Support "L" Bracket	L bracket mounts to vertical rails to provide additional support for rack-mounted models. 19.6 in. long x 2.3 in. high x 3.5 in. wide. Two (2) required per unit. 	128-1775

1.9 SAFETY

Service must be referred to authorized personnel. Using the power supply in a manner not specified by Kepco, Inc. may impair the protection provided by the power supply. Observe all safety precautions noted throughout this manual. Table 1-8 lists symbols used on the power supply or in this manual where applicable.

TABLE 1-8. SAFETY SYMBOLS



SYMBOL	Meaning
	WARNING! RISK OF ELECTRIC SHOCK!
	CAUTION: REFER TO REFERENCED PROCEDURE.
WARNING	INDICATES THE POSSIBILITY OF BODILY INJURY OR DEATH.
CAUTION	INDICATES THE POSSIBILITY OF EQUIPMENT DAMAGE.

TABLE I D.C. OUTPUT & SENSING TERMINALS	
1	OUTPUT SENSE
2	OUTPUT
3	GROUND
4	GROUND NETWORK
5	COMMON
6	COMMON SENSE



- NOTES:
- THIS DRAWING IS FOR THE FOLLOWING MODELS:
BOP 20-10M, BOP 36-6M, BOP 50-2M, BOP 50-4M, BOP 72-3M
BOP 100-1M AND BOP 100-2M.
 - MATERIAL:
A- CHASSIS AND BACK PLATE: NO. 16 GA (.059) C.R.S.
B- FRONT PANEL: 1/8 THK. ALUMINUM.
C- COVER: NO. 18 GA (.047) C.R.S.
 - FINISH:
A- CHASSIS AND BACK PLATE: CADMIUM PLATE WITH CHROMATE WASH.
B- FRONT PANEL: LIGHT GRAY PER FEDERAL STD596
COLOR NO. 26440.
C- COVER: CHARCOAL GRAY VINYL TEXTURE.
 - RACK MOUNTING: REMOVE (4) FEET FROM BOTTOM OF CHASSIS.
 - (4) PLASTIC MOUNTING INSERT UNDER FEET FOR 8-18 x 5/8 SELF-THREADING SCREWS (WITH 1/8 THICK MOUNTING PLATE).
 - DIMENSIONS IN PARENTHESIS ARE IN MILLIMETERS.
 - TOLERANCES:
A- BETWEEN MOUNTING HOLES ± 1/64 (± 0.4).
B- ALL FRONT PANEL DIMENSIONS TO MIL-STD-189.
C- ALL OTHER DIMENSIONS ± 1/32 (± 0.8) EXCEPT AS NOTED.

FIGURE 1-5. MECHANICAL OUTLINE DRAWING,
(BOP 3/4 RACK MODELS)

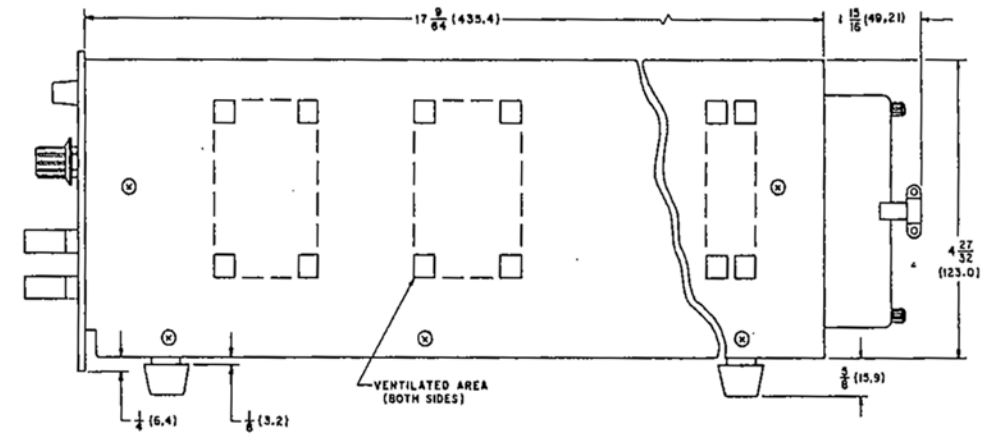
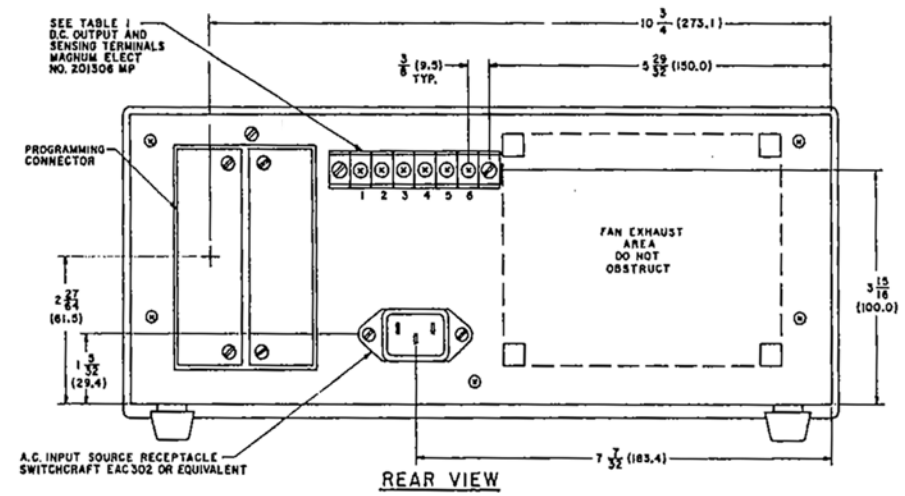
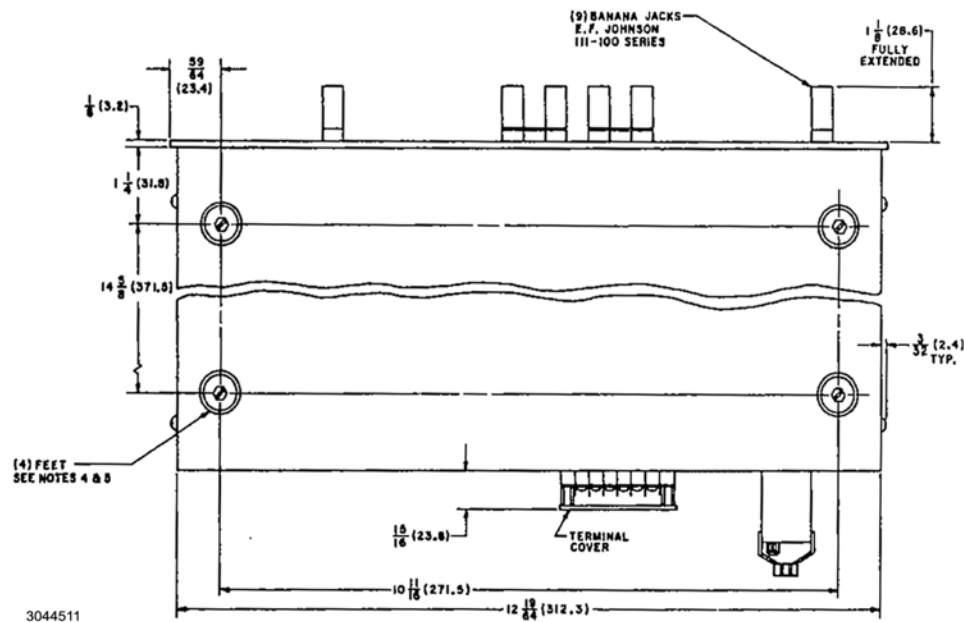
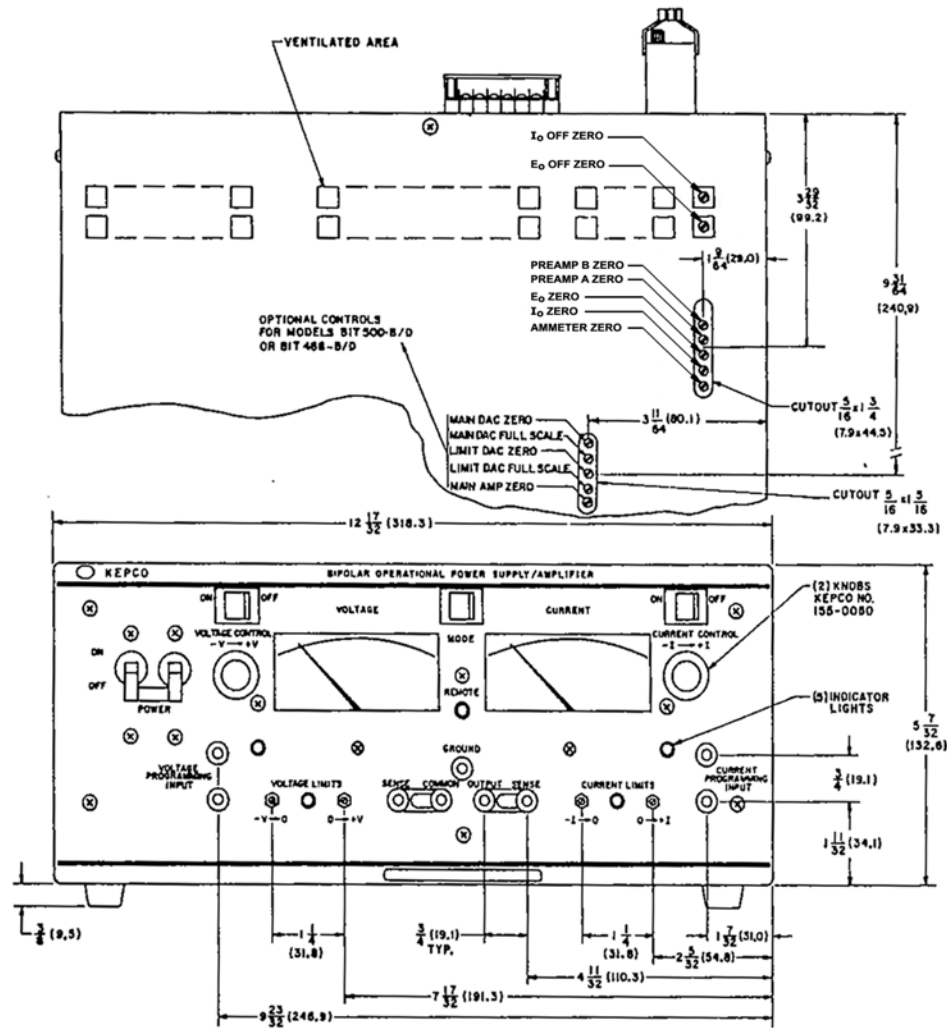
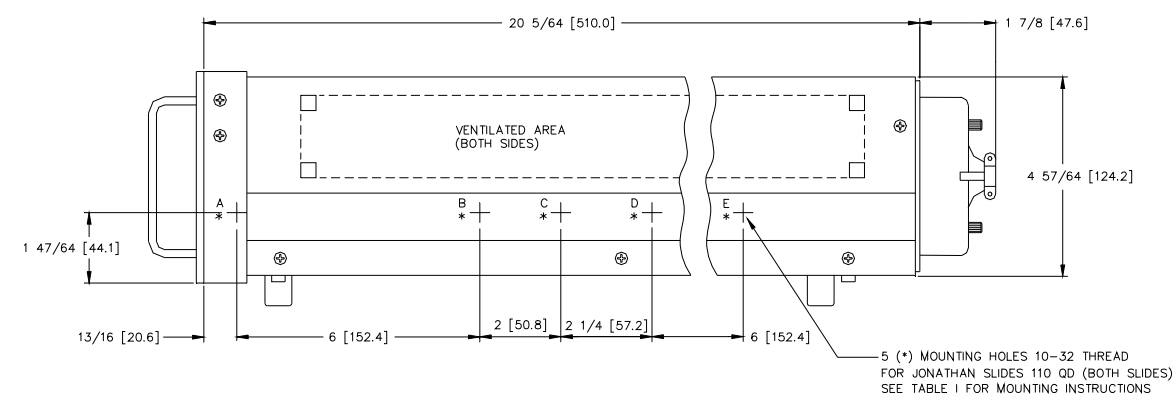
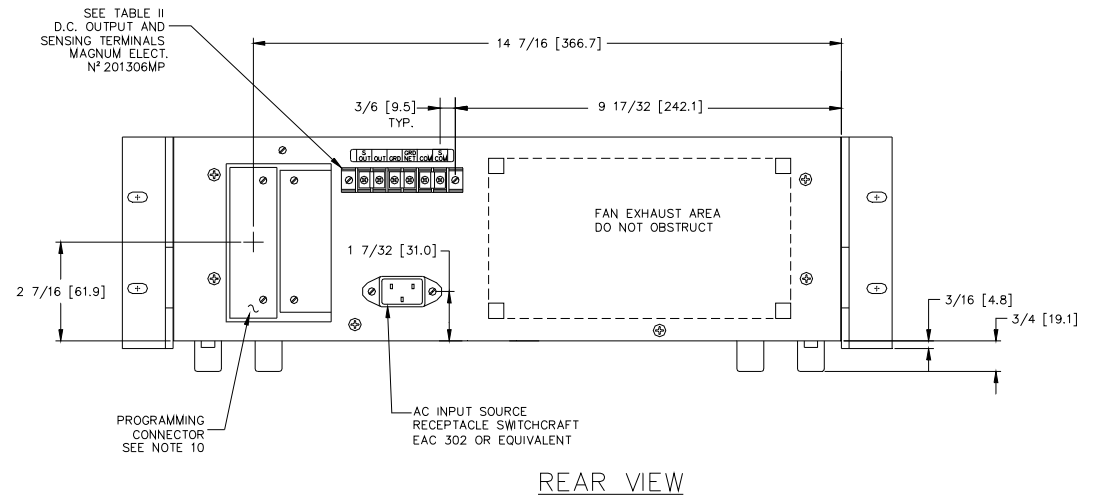
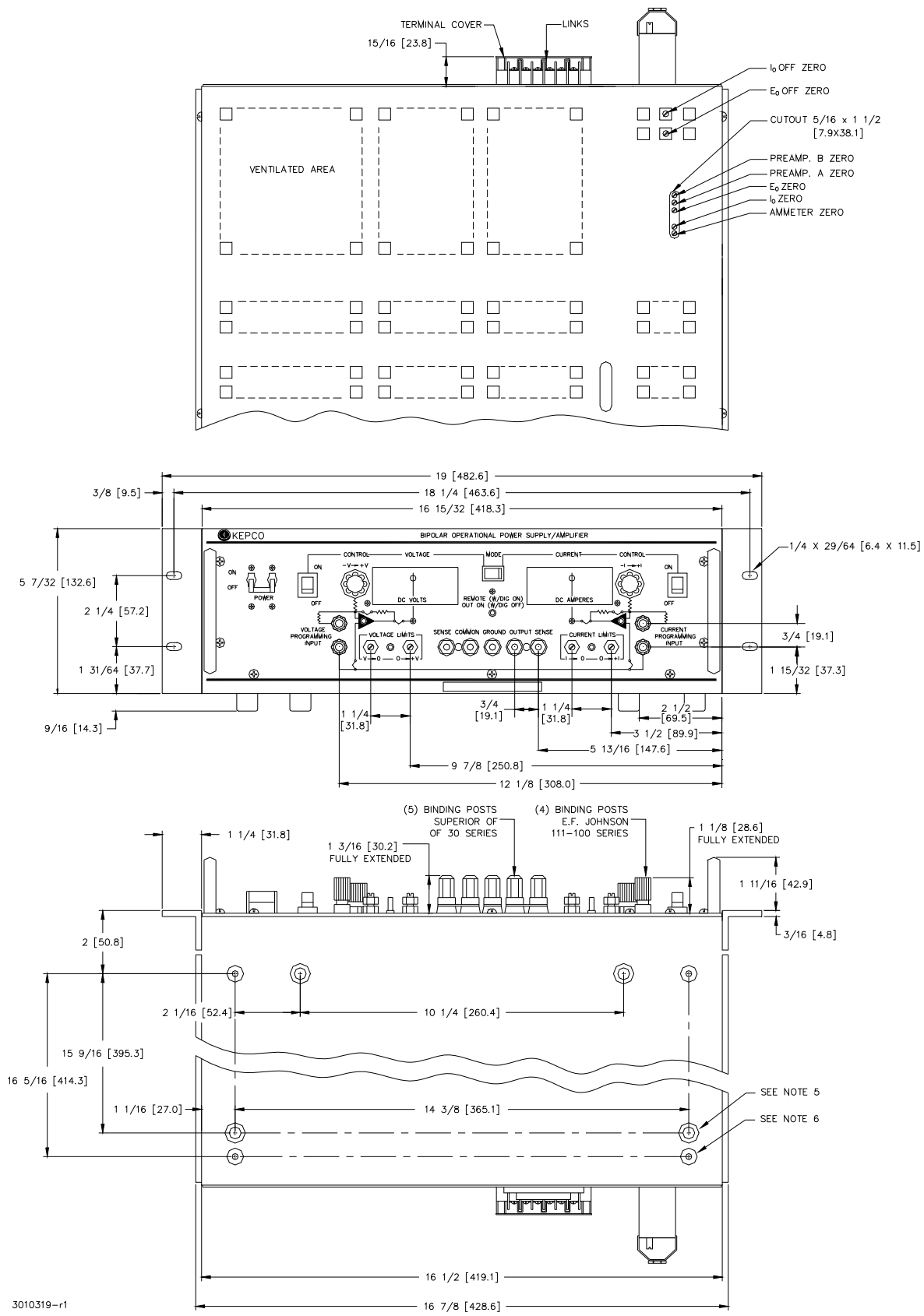

- NOTES:
- THIS DRAWING IS USED FOR THE BOP FULL RACK
 - MATERIAL:
 - A. CHASSIS AND BACK PLATE: No. 14 GA CRS
 - B. FRONT PANEL: 1/8 THICK ALUMINUM
 - C. COVER: No. 16 GA CRS
 - FINISH:
 - A. CHASSIS AND BACK PLATE: CADMIUM PLATE WITH CHROMATE WASH
 - B. FRONT PANEL: LIGHT GRAY PER FEDERAL STD 595 COLOR No. 26440
 - C. COVER: CHARCOAL GRAY VINYL TEXTURE
 - FIXED ANGLE BRACKETS AND CHASSIS SIDE SUPPORT BARS (BOTH SIDES), USED FOR RACK OR CABINET INSTALLATION CAN BE REMOVED FOR BENCH OPERATION
 - RACK OR CABINET MOUNTING: REMOVE (4) METAL FEET
 - (4) PLASTIC INSERTS FOR 1/4-20 THREAD CUTTING SCREWS 5/8 LONG (WITH 1/8 MOUNTING SURFACE THICKNESS)
 - IF INSTALLATION WITHOUT SLIDES IS DESIRED, THE UNIT MUST BE SUPPORTED BY A RIGID PLATFORM OR BY A FIXED BRACKET MOUNTED ON THE RACK
 - DIMENSIONS IN PARENTHESIS ARE IN MILLIMETERS
 - TOLERANCES:
 - A. BETWEEN MOUNTING HOLES ±1/64 [0.4]
 - B. ALL FRONT PANEL DIMENSIONS TO MIL-STD-189
 - C. ALL OTHER DIMENSIONS ±1/32 [.8] EXCEPT AS NOTED
 - PROGRAMMING CONNECTOR, PC-15 WITH DEFAULT WIRING (PC-12 REPRESENTS THE UN-WIRED CONNECTOR)

KEPCO P/N	SLIDE TYPE	MOUNTING TABLE I				
		USED MOUNTING HOLE				
		A	B	C	D	E
108-0067	110 QD-20-2			NOT USED		●
108-0156	110 QD-22-2		NOT USED		NOT USED	
108-0192	110 QD-24-2		NOT USED		NOT USED	●

● "E" HOLE HAS TO BE ADDED TO SLIDES BOTH SIDES 0.199 DIA. HOLE 16-1/4 FROM "A" HOLE

TABLE II D.C. OUTPUT AND SENSING TERMINALS	
1	OUTPUT SENSING
2	OUTPUT
3	GROUND
4	GROUND NETWORK
5	COMMON
6	COMMON SENSING

FIGURE 1-6. MECHANICAL OUTLINE DRAWING, (BOP FULL RACK MODELS)

SECTION 2 - INSTALLATION

2.1 UNPACKING AND INSPECTION.

This instrument has been thoroughly inspected and tested prior to packing and is ready for operation. After careful unpacking, inspect for shipping damage before attempting to operate. Perform the preliminary operational check as outlined in PAR. 2.5. If any indication of damage is found, file an immediate claim with the responsible transport service.

2.2 TERMINATIONS, CONTROLS AND INDICATORS

- a) Front Panel: Refer to Figure 2-1. See Table 2-1 for an explanation of terminations, controls and indicators.
- b) Rear Panel: Refer to Figure 2-2 and Table 2-2 for an explanation of terminations.

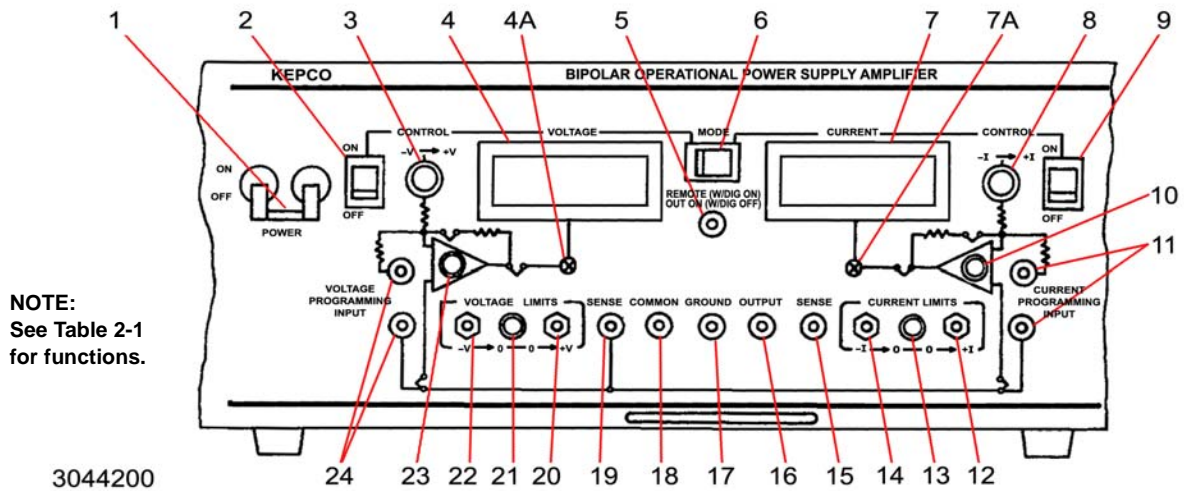

FIGURE 2-1. BOP TERMINATIONS AND CONTROLS, FRONT PANEL

TABLE 2-1. BOP FRONT PANEL TERMINATIONS AND CONTROLS

FIG. 2-1 INDEX NO.	NAME OF TERMINATION OR CONTROL	FUNCTION
FRONT		
1	A-C POWER circuit breaker	A-C circuit breaker/power switch.
2	VOLTAGE CONTROL switch	ON-OFF switch is set to ON to allow VOLTAGE control (3) to provide manual adjustment of the BOP d-c output voltage
3	VOLTAGE control	Provides manual adjustment of BOP d-c output voltage when VOLTAGE CONTROL switch set to ON.
4	VOLTAGE meter	D suffix models: E_o d-c digital output voltmeter M suffix models: E_o d-c analog output voltmeter
4A	Voltage Meter Zero Adjust	M suffix models only: Mechanical voltmeter zero adjustment.

TABLE 2-1. BOP FRONT PANEL TERMINATIONS AND CONTROLS (CONTINUED)

FIG. 2-1 INDEX NO.	NAME OF TERMINATION OR CONTROL	FUNCTION
5	REMOTE (W/DIG ON) OUT ON (W/DIG OFF) indicator	Dual function LED indicator: The unit is in local mode on power up: the indicator is on for Output ON, off for Output OFF. However, if SYST:REM ON command is sent via the digital interface (BOPs with digital card installed only), the indicator no longer indicates output ON/OFF status, but instead stays on to indicate digital remote status until either SYST:REM OFF is sent or unit is put into local mode by other means. While unit is in digital remote status, output ON/OFF status can be checked by sending OUTPut? via the digital interface: unit returns 1 for ON and 0 for OFF.
6	MODE switch	Operating mode switch to select either Voltage or Current mode.
7	CURRENT meter	D suffix models: I _O d-c digital output ammeter M suffix models: I _O d-c analog output ammeter
7A	Current Meter Zero Adjust	M suffix models only: Mechanical current meter zero adjustment.
8	CURRENT control	Provides manual adjustment of BOP d-c output current when CURRENT CONTROL switch set to ON.
9	CURRENT CONTROL switch	Provides manual adjustment of BOP d-c output current when CURRENT CONTROL switch set to ON.
10	I _O Mode indicator	LED lamp, indicating current mode operation.
11	CURRENT PROGRAMMING INPUT terminals	Programming input terminals for current control channel.
12	CURRENT LIMITS (+) control	Control for manual adjustment of the positive (+) current limit.
13	CURRENT LIMIT indicator	LED lamp, indicating current limiting operation.
14	CURRENT LIMITS (-) control	Control for manual adjustment of the negative (-) current limit.
15	SENSE (Output) terminal	Used for OUTPUT sense connection (in parallel with corresponding rear panel barrier strip terminal).
16	OUTPUT terminal	Used to connect power supply to load in (parallel with corresponding rear panel barrier strip terminal).
17	GROUND terminal	Chassis ground terminal (in parallel with corresponding rear panel barrier strip terminal)
18	COMMON terminal	Provides common return for power supply output (parallel with rear panel barrier strip terminal)
19	SENSE (Common) terminal	Used for COMMON sense connection (in parallel with corresponding rear panel barrier strip terminal).
20	VOLTAGE LIMITS (+) control	Control for manual adjustment of the positive (+) voltage limit.
21	VOLTAGE LIMIT indicator	LED lamp, indicating voltage limiting operation.
22	VOLTAGE LIMITS (-) control	Control for manual adjustment of the negative (-) voltage limit.
23	E _O Mode indicator	LED lamp, indicating voltage mode operation.
24	VOLTAGE PROGRAMMING INPUT terminals	Programming input terminals for voltage control channel.

TABLE 2-2. BOP REAR PANEL TERMINATIONS AND CONTROLS

FIG. 2-2 INDEX NO.	NAME OF TERMINATION OR CONTROL	FUNCTION
1	PC 15	Rear Programming Connector configured for front panel control. See Table 1-5 for details. NOTE: Unwired connector (PC 12) is available as an accessory (see Table 1-7).
2	REAR TERMINALS (TB201)	Rear barrier strip with output, sensing and chassis ground terminals.
3	P201	A-C power input jack. accepts 3-wire line cord (supplied).

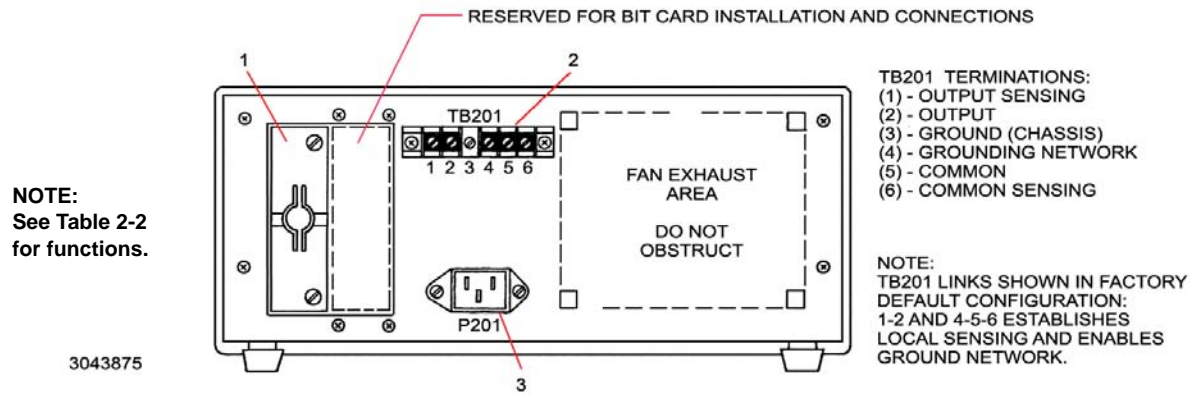

FIGURE 2-2. BOP TERMINATIONS AND CONTROLS, REAR PANEL

2.3 A-C INPUT REQUIREMENTS

This power supply is shipped wired for operation on a single phase, nominal 115V a-c line. For operation on other a-c source voltages, refer to FIG. 2-3. Check your prevailing nominal source voltage and change the links on the barrier strip of T201 according to the table provided in FIG. 2-3. The circuit breaker (CB101) remains equally effective at all input voltages.

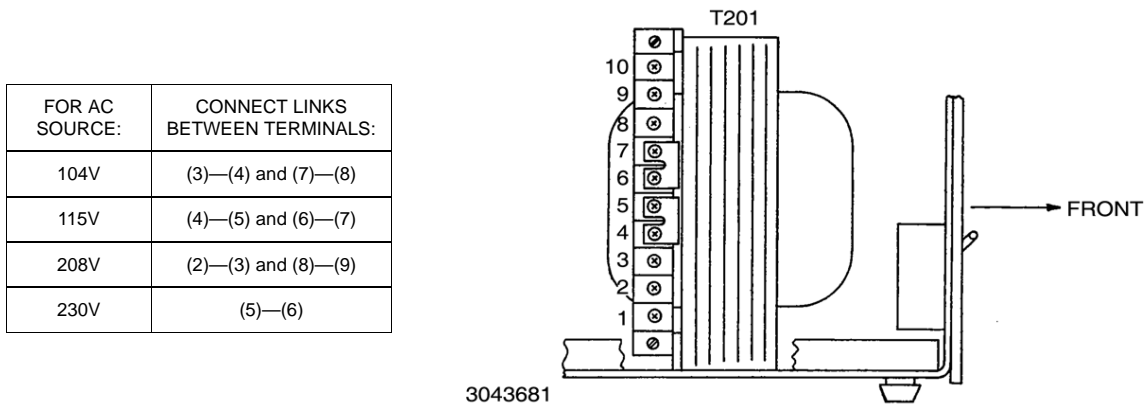

FIGURE 2-3. A-C SOURCE VOLTAGE SELECTION

2.4 COOLING

The components in the BOP power supply rely on forced air cooling for the maintenance of their operating temperature. Side panel openings and the top of the case must be kept clear from all obstructions to ensure air circulation. Periodic cleaning of the interior of the power supply is recommended. **If the BOP is rack-mounted or installed into confined spaces, care must be taken that the ambient temperature (the temperature immediately surrounding the power supply) does not rise above 55°C (~131°F).**

2.5 PRELIMINARY CHECKOUT



CAUTION:The PC 15 connector must be connected for the unit to operate.

NOTES: 1. The Rear Programming Connector supplied with the unit (PC 15) is prewired for local control (see Simplified Schematic Diagram, Figure 3-29) and must be attached to the BOP. An unwired Rear Programming Connector (PC 12) is available as an accessory (see Table 1-7).

2. By default, with no signal at pins 21 and 50 of the rear programming connector, the output is enabled. The output can be controlled, off and on, by logic signals applied to rear programming connector pin 21 referenced to pin 23 (non-isolated control) or pin 50 referenced to pin 48 (isolated control). The logic of the isolated control can be established by the pin 21 signal level; see Table 1-5 for more details.

The default setting of the front panel controls puts the unit in voltage mode with voltage set to zero (Voltage Mode indicator is on).

3. If the unit is set in current mode with no load connected, the unit will go into voltage limit, displaying the preadjusted limit value with the same polarity as the output current offset or current setpoint value. The front panel Voltage Limit indicator will go on and the Current Mode indicator will go off.

A simple operating check after unpacking, and before permanent installation, is advisable to ascertain whether the BOP has suffered damage in shipment. Refer to Figures through 2-2 and Tables 2-1 and 2-2 for the location and function of the operating controls and terminals. Proceed as follows:

1. Connect the BOP to a 115V a-c source, or refer to paragraph 2-4 for conversion to other a-c input voltages if required.

NOTE: The rear sensing links must be attached to the rear barrier strip (TB201) of the BOP as shown in Figure 2-2 and the Rear Programming Connector must be attached and secured.

2. Set the BOP front panel controls as follows. The controls are identified with the nomenclature used in Table 2-1 and the identifying numbers used in Figure 2-1.
 - a) Set MODE switch (6), to VOLTAGE.
 - b) Set VOLTAGE CONTROL switch (2), to ON, and rotate VOLTAGE control (3) to its maximum counterclockwise position.
 - c) Set a-c circuit breaker/POWER switch (1) to ON. DO NOT repeatedly toggle the POWER on/off switch as this may cause unit to fault. If actuator does not lock when

released, wait a few seconds before trying again. The circuit breaker is “trip-free,” if overload exists, contacts cannot be held closed by actuator.

3. At the front panel, E_o MODE indicator (23, Figure 2-1) will be on. REMOTE (W/DIG ON) / OUT ON (W/DIG OFF) (5) indicator will be on to indicate the output is enabled. The front panel VOLTAGE meter (4) will show reading listed in Table 2-3 for applicable model.

TABLE 2-3. PRELIMINARY CHECKOUT READINGS

MODEL ⁽¹⁾	PAR. 2.5, STEP 3 (VOLTS)	PAR. 2.5, STEP 4 (VOLTS)	PAR. 2.5, STEP 10 (AMPS)	PAR. 2.5, STEP 11 (AMPS)
BOP 5-20	-5.25 ±0.05	+5.25 ±0.05	-21 ±0.2	+21 ±0.2
BOP 20-5	-21.0 ±0.2	+21.0 ±0.2	-5.25 ±0.05	+5.25 ±0.05
BOP 50-2	-52.5 ±0.5	+52.5 ±0.5	-2.1 ±0.02	+2.1 ±0.02
BOP 100-1	-105 ±1	+105 ±1	-1.05 ±0.01	+1.05 ±0.01
BOP 20-10	-21.0 ±0.2	+21.0 ±0.2	-10.5 ±0.1	+10.5 ±0.1
BOP 36-6	-37.80 ±0.36	+37.80 ±0.36	-6.3 ±0.06	+6.3 ±0.06
BOP 50-4	-52.5 ±0.5	+52.5 ±0.5	-4.2 ±0.04	+4.2 ±0.04
BOP 72-3	-75.6 ±0.72	+75.6 ±0.72	-3.15 ±0.03	+3.15 ±0.03
BOP 100-2	-105 ±1	+105 ±1	-2.1 ±0.02	+2.1 ±0.02
BOP 200-1	-210 ±2	+210 ±2	-1.05 ±0.01	+1.05 ±0.01
BOP 20-20	-21.0 ±0.2	+21.0 ±0.2	-21 ±0.2	+21 ±0.2
BOP 36-12	-37.80 ±0.36	+37.80 ±0.36	-12.6 ±0.12	+12.6 ±0.12
BOP 50-8	-52.5 ±0.5	+52.5 ±0.5	-8.4 ±0.08	+8.4 ±0.08
BOP 72-6	-75.6 ±0.72	+75.6 ±0.72	-6.3 ±0.06	+6.3 ±0.06
BOP 100-4	-105 ±1	+105 ±1	-4.2 ±0.04	+4.2 ±0.04

4. Turn the VOLTAGE control (3) clockwise through its range, while observing the front panel VOLTAGE meter. The BOP output voltage should smoothly respond, from the maximum negative output voltage, through zero, to the maximum positive output voltage of the BOP as listed in Table 2-3 for applicable model.
5. At the rear panel, connect a wire jumper between pins 21 and pin 23 of the rear programming connector. Verify the front panel VOLTAGE meter shows zero Volts and the REMOTE (W/DIG ON) / OUT ON (W/DIG OFF) indicator goes off to indicate the output is disabled.
6. At the front panel, turn a-c circuit breaker/POWER switch (1) to OFF.
7. Connect a short circuit between the OUTPUT (16) and the COMMON (18) terminals on the front panel.
8. At the rear panel, remove the wire jumper between pins 21 and 23 of the rear programming connector.
9. Set the BOP front panel controls as follows:
 - a) Set MODE switch (6), to CURRENT.

- b) Set CURRENT CONTROL switch (9), to ON, and rotate CURRENT control (8) to its maximum counterclockwise position.
 - c) Set a-c circuit breaker/POWER switch (1) to ON.
10. I_o MODE indicator (10) will be on and REMOTE (W/DIG ON) / OUT ON (W/DIG OFF) (5) indicators will be on indicating the unit is in current mode and the output is enabled. The front panel CURRENT (7) meter will show reading listed in Table 2-3 for applicable model.
 11. Turn the CURRENT control (8) clockwise through its range, while observing the front panel CURRENT meter. The BOP output current should smoothly respond, from the maximum negative output current, through zero, to the maximum positive output current of the BOP as listed in Table 2-3 for applicable model.
 12. At the rear panel, connect a wire jumper between pins 21 and pin 23 of the rear programming connector. Verify the front panel CURRENT (7) meter shows zero Amperes and the REMOTE (W/DIG ON) / OUT ON (W/DIG OFF) indicator (5) goes off to indicate the output is disabled.
 13. Turn a-c circuit breaker/POWER switch (1) to OFF. Remove the short circuit from the output terminals. At the rear panel, remove the wire jumper between pins 21 and 23 of the rear programming connector. This concludes the preliminary check-out of the BOP.

NOTE: If an application requires that the output be OFF at power up and no signal (or logic 0) is to be applied to pin 50 referenced to pin 48 (isolated remote on-off control) of the rear programming connector, then connect a permanent jumper between pins 21 and 23 of the rear programming connector. With this jumper in place, a logic 1 must be applied to pin 50, referenced to pin 48, of the rear programming connector to enable the output. See Table 1-5 for details.

2.6 INSTALLATION OF FULL-RACK BOP MODELS

NOTE: For all installations into confined spaces, care must be taken that the temperature immediately surrounding the unit does not exceed the maximum specified ambient temperature (55° C).

Refer to the Mechanical Outline Drawing, Figure 1-5 for 3/4-rack models, Figure 1-6 for full-rack models. Full-rack BOP models are delivered with the Fixed Angle Brackets and the Chassis Side Support Bars installed. For bench operation, both of these components may be removed.

The full-rack BOP unit may be installed into standard (19-inch) equipment racks, or onto any other flat surface after removing the four (4) bottom aluminum feet. If chassis slides are not used, the BOP may be installed onto any flat surface by means of the provided plastic mounting inserts on the bottom of the BOP chassis.

NOTE: If slide installation (as described below) is not desired, other means of supporting the unit in the rear must be provided (additional rear brackets or a solid platform, for example) since the front angle brackets alone are not sufficient to support the full weight of the unit.

2.6.1 SLIDE INSTALLATION.

The Chassis Slide Support Bars of the BOP are pre-drilled to accept Jonathan Series 110 QD slides. The slides listed in Table 2-4 can be accommodated.

TABLE 2-4. CHASSIS SLIDE MOUNTING HOLES

MODEL	KEPCO P/N	MOUNTING HOLES USED				
		A	B	C	D	E
110 QD-20-2	108-0067	X	X	O	X	DR
110 QD-22-2	108-0156	X	O	X	O	X
110 QD-24-2	108-0192	X	O	X	O	DR

KEY: X = Hole Used
 O = Hole Not Used
 DR = Hole must be drilled into chassis part of slide, each side, 0.199 in. dia., 16-1/4 in. from "A" hole.

To install the slides, refer to Figure 2-4 and proceed as follows:

1. Remove screws "A" through "E" from left and right chassis slide support bars. (Do not discard).
2. Determine the required hole-pattern for the selected slide model from Table 2-4.
3. Drill the "E" hole into both left and right chassis sections of slide if required.
4. Mount the chassis section of the slide to the left and right side of the BOP as shown in Figure 2-4. Use the same 10-32 x 1/2" mounting screws removed in step 1.

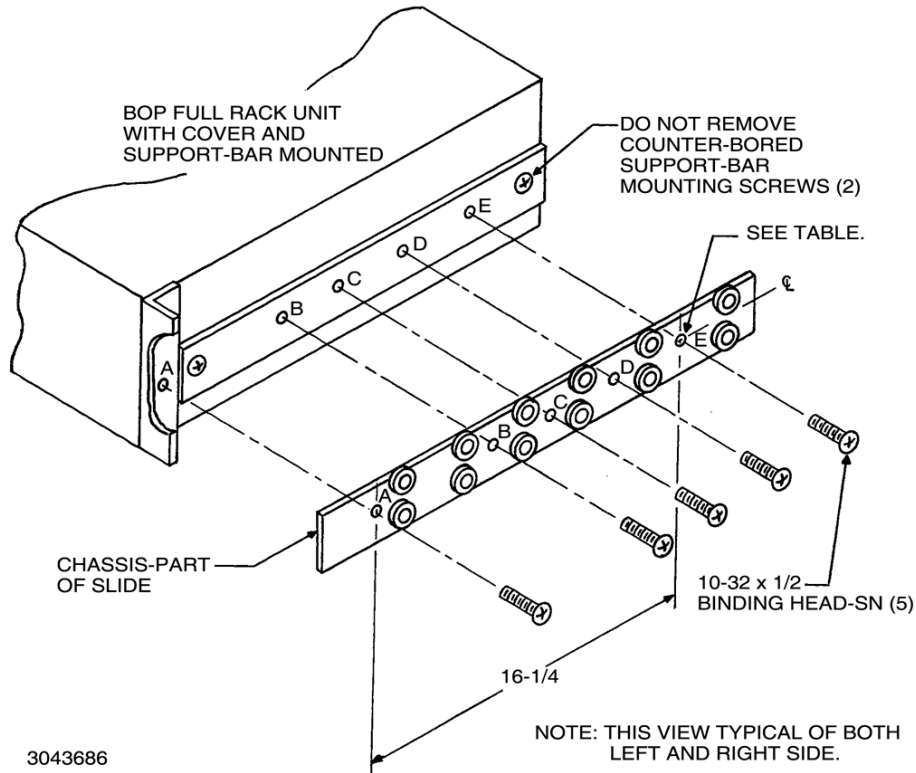

FIGURE 2-4. SLIDE INSTALLATION ON FULL-RACK UNITS

2.7 LOAD CONNECTION

Load connections to the BOP power supply are achieved via the OUTPUT and COMMON terminals located on the front and rear panels. **Use only one of these output ports.** Sense connections must be made from the same location (front or rear panel) as the output and common power connections.

2.7.1 LOAD CONNECTION, LOCAL SENSING

The basic interconnections between the BOP and the load using local sensing are shown in Figure 2-5 (using the rear panel) and Figure 2-6 (using the front panel).

The load wire size for the 2-wire connection shown should be rated for the nominal output current of the BOP and tied together to keep parasitic inductance low and to reduce possible “pick-up” from stray magnetic fields. The basic 2-wire connection is useful where the voltage drop in the load wires is small or of minor consequence, as for example, operation in constant current mode.

2.7.2 LOAD CONNECTION, REMOTE SENSING

The basic interconnections between the BOP and the load using remote sensing are shown in Figure 2-7 (using the rear panel) and Figure 2-8 (using the front panel). This is the recommended load connection for all applications requiring minimum load effect across a remote load. A twisted or shielded pair of wires (No. 22 AWG minimum) are connected from the BOP sensing terminals to the load. This remote error sensing technique will compensate for load wire voltage drops up to 0.5 volts per wire (0.25 volts per wire for BOP 5-20D and BOP5-30D).

NOTE: Observe polarities: the COMMON sensing wire must go to the COMMON load wire, the OUTPUT sensing wire must go to the OUTPUT load wire.

NOTE: The following explanation of AC and DC grounding can apply to any Kepco power supply even though this text applies specifically to BOP Series.

2.7.3 A-C GROUND

The metal cases of electronic equipment which are operated from the a-c power line must be kept at ground potential at all times. If the 3-wire line cord with 3-prong safety plug (supplied with this equipment) is used in combination with a properly grounded a-c power outlet, this is taken care of automatically. If a non-grounded outlet is used, the case must be earth-grounded separately. A separate GROUND terminal is provided for this purpose on the front panel as well as on the rear of the BOP.

The GROUND terminal is connected to chassis of the unit and to the local earth-ground potential through the A-C power line cord. It can be used a) as a grounding point for the output of the unit (COMMON terminal), and b) for doubling the a-c power cord earth-ground connection if necessary by providing a separate connection to the local earth-ground point.

CAUTION: Never connect the BOP output terminal (or the load terminal tied to the output terminal) to earth-ground. Otherwise, if the controlling device is grounded, the BOP can be damaged by the output limit current flowing inside the BOP along the programming signal return path.

CAUTION: Do not connect both the load and the programming device return (common) to earth-ground. Otherwise, if the common power connection between the BOP and the load is lost, the BOP can be damaged by output current flowing inside the BOP along the programming signal return path.

CAUTION: Do not use the programming return terminal as a tap point for the load return because the BOP can be damaged by output current flowing inside the BOP along the programming signal return path.

In conclusion, if the application needs to have its common point tied to earth ground, make the common terminal to earth-ground connection for only ONE of the following: a) BOP, b) load, c) a device connected to the BOP output, d) a programming device.

2.7.4 D-C GROUND

Specified ripple and noise figures listed in Table 1-1 for operational power supplies are valid only with the COMMON side of the output/load circuit returned to an earth-ground point as shown in Figures 2-5 through 2-8.



CAUTION: If the programming device return is tied to earth-ground, leave the BOP output floating. Otherwise, instability and inaccuracy will occur.

If the application requires, the COMMON of the BOP may be floated up to 500V d-c (or peak) off ground. For this case, due to the common mode noise current flowing through a higher impedance, the resulting ripple/noise will be larger than published specifications. If the application must be grounded, connect a single return/common point of the application (including programming device, BOP and load) to earth-ground. The exact location of the best return earth-ground point must be carefully selected for minimum ripple/noise output.

The GROUNDING NETWORK terminal is tied to GROUND (chassis) terminal through a series capacitor-resistor network. Connecting the GROUNDING NETWORK terminal to the COMMON terminal reduces common noise current flowing through the load and, if a BIT card is installed, it ensures that the dynamic swing of the output does not affect the digital section.

NOTE:
FRONT SENSING LINKS MUST BE REMOVED. REAR SENSING LINKS MUST BE CONNECTED AS SHOWN.

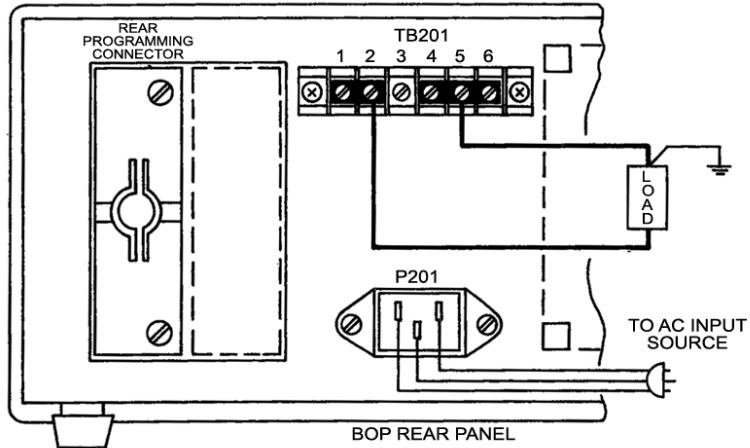

3043878

FIGURE 2-5. LOAD CONNECTION USING LOCAL SENSING AT REAR PANEL

NOTE:
REAR SENSING LINKS MUST BE REMOVED. FRONT SENSING LINKS MUST BE CONNECTED AS SHOWN.

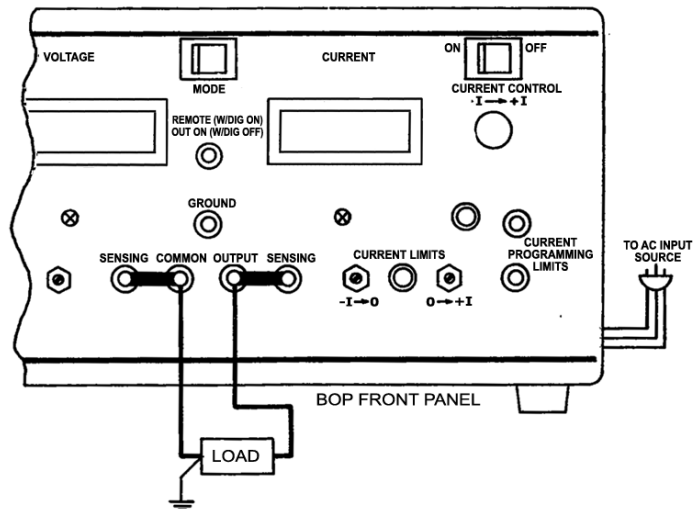

3043688

FIGURE 2-6. LOAD CONNECTION USING LOCAL SENSING AT FRONT PANEL

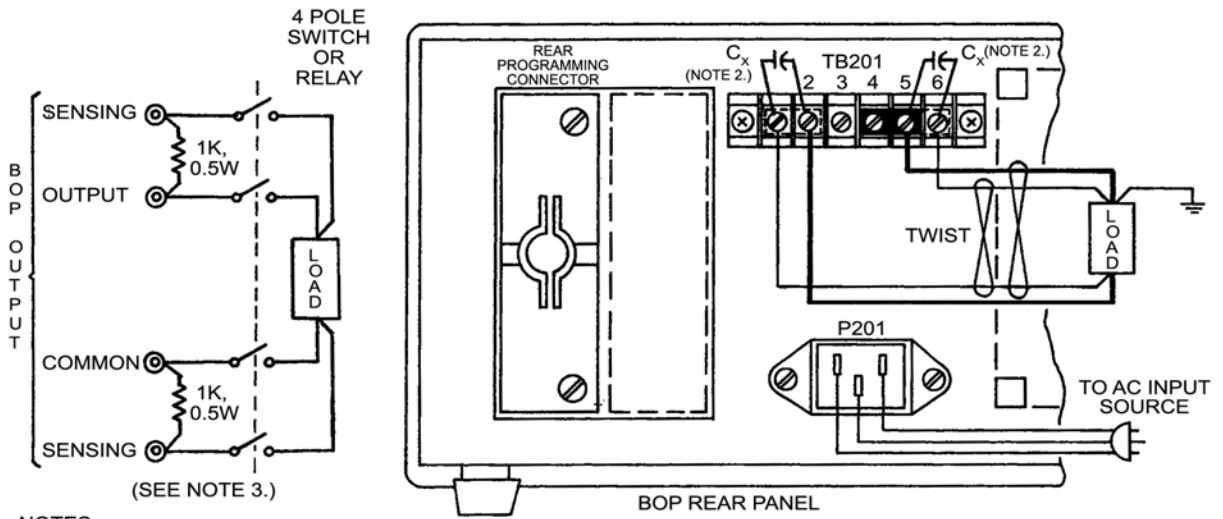

NOTES:

1. Front and rear sensing links must be removed.
2. For applications requiring very long connections to the load, additional external capacitors (C_x) should be connected as shown to compensate for the lead inductance of the connecting wires.
3. For applications requiring manually switched or relay driven output connections, external resistors must be connected as shown. All connections must be made and broken simultaneously.
4. Use separate properly rated twisted pair wires for output power and output sensing connections.

3043879

FIGURE 2-7. LOAD CONNECTION USING REMOTE SENSING AT REAR PANEL

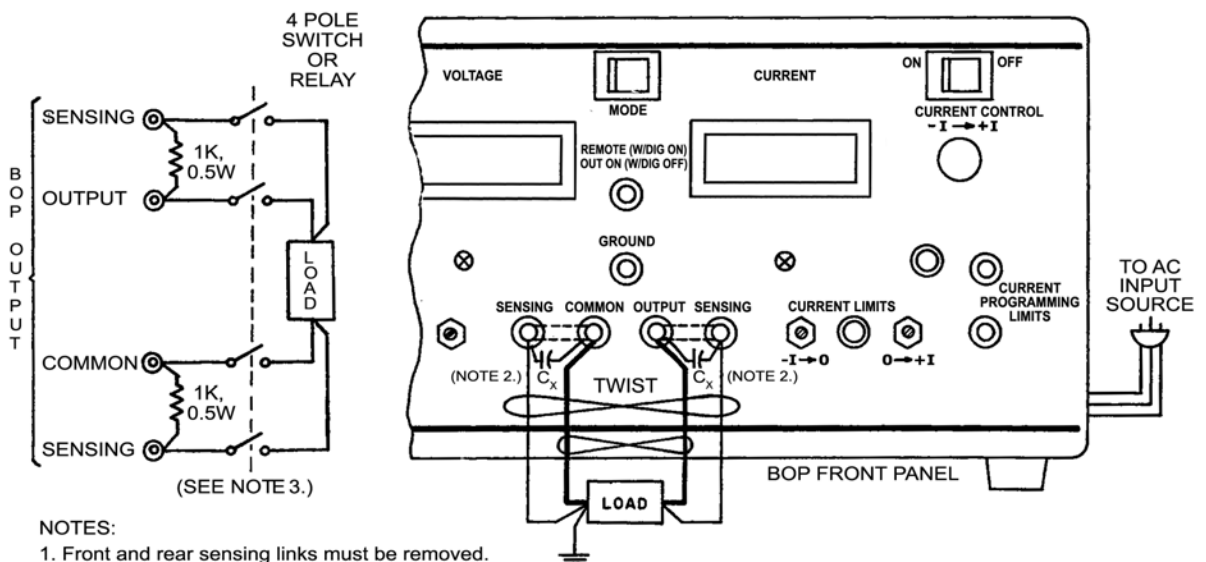

NOTES:

1. Front and rear sensing links must be removed.
2. For applications requiring very long connections to the load, additional external capacitors (C_x) should be connected as shown to compensate for the lead inductance of the connecting wires.
3. For applications requiring manually switched or relay driven output connections, external resistors must be connected as shown. All connections must be made and broken simultaneously.
4. Use separate properly rated twisted pair wires for output power and output sensing connections.

3043880

FIGURE 2-8. LOAD CONNECTION USING REMOTE SENSING AT FRONT PANEL

SECTION 3 - OPERATION

3.1 INTRODUCTION

BOP Bipolar Operational Power Supplies can be used in a great variety of applications. As a precision voltage or current source, the BOP output can be controlled locally by means of the front panel bipolar VOLTAGE and CURRENT controls or remotely by means of resistance or voltage signals or an optional digital interface (see PAR. 3.8). Independently adjustable or remotely programmable limit circuits for both output voltage and output current protect a sensitive load from any overvoltage or overcurrent.



CAUTION: The application schematic diagrams found in this section, are valid for analog control only. If a digital card is installed, analog control is only possible if the digital card is disabled. See application note titled "How to Disable BIT Card in a) BOP models with BIT 802E or 4886 Cards Installed or b) BOP 2X-DE Models" that can be downloaded from the Kepco web site at:

www.kepcopower.com/support/bop-app-note.htm



NOTE: Before using the BOP in any application, please refer to Section 2 to get acquainted with the operating controls, a-c power requirements and information on load connections and grounding. Front panel components identified by index numbers in parentheses are shown in Figure 2-1.

3.2 POWER SUPPLY BASICS

As a Bipolar Amplifier, the BOP output responds to such input signals as sine, square or triangular waves. A ± 10 volt input signal will program the BOP output (voltage or current) through its rated output ranges. Built-in preamplifiers, for the voltage, as well as the current channel of the BOP, permit amplification of the control signals to the required amplitude and provide the interface with high, as well as low, impedance signal sources.

3.2.1 SAFETY PRECAUTIONS

Detailed examples of the more popular applications are described in the following paragraphs. Before actual operation, however, the following safety precautions must be carefully considered.



WARNING

Exercise care in making all connections to and from the BOP terminals. Remove a-c power from the BOP before making any connections.

Wires and/or cables connected from the BOP terminals to external components or programming devices must be properly insulated and securely terminated on both sides to make accidental touch impossible. Do not use banana plugs with exposed screws or other exposed metal parts at the front panel output terminals!

The BOP chassis must be safety-grounded to a reliable a-c source earth-ground. A safety-ground may be established by using a grounded a-c power outlet or, if the latter is not available, by means of a separate wire from the provided GROUND terminal to a reliable a-c source earth-ground point.

The COMMON output terminal of the BOP can be either grounded or floating, depending on the application. Additional precautions must be taken to make any user access to the output terminals impossible.

The BOP must always have sensing configured between OUT and OUTS and between COM and COMS. For voltage mode choose either local or remote sensing as desired (front or rear). For current mode use local sensing (front or rear).

CAUTION: DO NOT repeatedly toggle the POWER on/off switch as this may cause unit to fault. If actuator does not lock when released, wait a few seconds before trying again. The circuit breaker is “trip-free;” if overload exists, contacts cannot be held closed by actuator.

3.2.2 SIMPLIFIED APPLICATION AND TEST SETUP DIAGRAMS

Application and test set up diagrams on the following pages show the symbolic and simplified representation of the four programmable circuits of the BOP:

- Voltage Control Channel: see Figure 3-2 and PAR. 3.3.1 for local control.
- (\pm) I_O Limit Circuits: See Figure 3-3 and PAR. 3.3.2 for local control.
- Current Control Channel: see Figure 3-4 and PAR. 3.3.3 for local control.
- (\pm) E_O Limit Circuits: see Figure 3-5 and PAR. 3.3.4 for local control.

The complete simplified diagram is shown in Figure 3-29 at the end of this section. The four circuits can be programmed separately as described in the examples in this section. Of these four circuits, only three can be used at one time, either voltage loop with current limit and voltage limit loops or current loop with current limit and voltage limit loops.. However, most of the time either the voltage loop with \pm current limit loops or the current loop with \pm voltage limit loops are being exercised. The two main bipolar voltage and current channels are manually selected by the front panel MODE switch. To understand how to modify connections of the rear programming connector, see PAR. 3.2.3.

NOTES: BOPs have front and rear output terminals. Only the front terminals are shown on all subsequent simplified diagrams.

For all simplified application diagrams in this section, pin C (Common) of the rear programming connector is available at pins 23, 25, 27, 29, 31, and 33.

3.2.3 REAR PROGRAMMING CONNECTOR

The rear programming connector **MUST** be installed for the power supply to operate. Model PC 15 rear programming connector is preconfigured for local control. Model PC 12 is unwired and can be configured as needed per the applicable simplified diagram. The numbered terminals in the simplified diagrams of this section correspond to the terminals of the Rear Programming Connector (see Figure 3-30 at the end of this section). The terminal designated C (Common) corresponds to terminals numbers 23, 25, 27, 29, 31 or 33 on the Rear Programming Connector. Figure 3-1 is an example of how to change the connections indicated by the simplified diagrams.

There are two types of PC 15 connectors in use: P/N 195-0039 or P/N 195-0121. These are functionally identical but physically different.

P/N 195-0039 (older) uses connector pins with wire jumpers soldered to the connector pins to configure the BOP for local operation. When noted by the simplified diagrams, either remove or add jumpers as directed.

P/N 195-0121 (newer) uses printed circuit traces routed through test points to configure the BOP for local operation. When noted by the simplified diagrams, either cut (or desolder) connections at the specified TP or add wire jumper(s) at specified pins,

Notes that apply to only one type of PC 15 are clearly marked. Adding jumpers or making external connections are typically the same for both types

As an example, The instructions of Figure 3-22, Note 2 (repeated below) are illustrated in Figure 3-1.

“On Rear Programming Connector install jumper between (32) and (6). For 195-0039 remove jumper between terminals (3) and (6). For P/N 195-0121: Cut TP4 and TP5.”

If P/N 195-0039 is used, this means unsoldering and removing the jumper between terminals 3 and 6. The jumper between terminals 6 and 32 will already be in place (see Figure 3-1).

If P/N 195-0121 is used, this means soldering a jumper between pins 6 and 32 and cutting or desoldering TP4 (to break the connection between pins 3 and 6) and TP5 (to break the connection between pins 3 and 32) (see Figure 3-1).

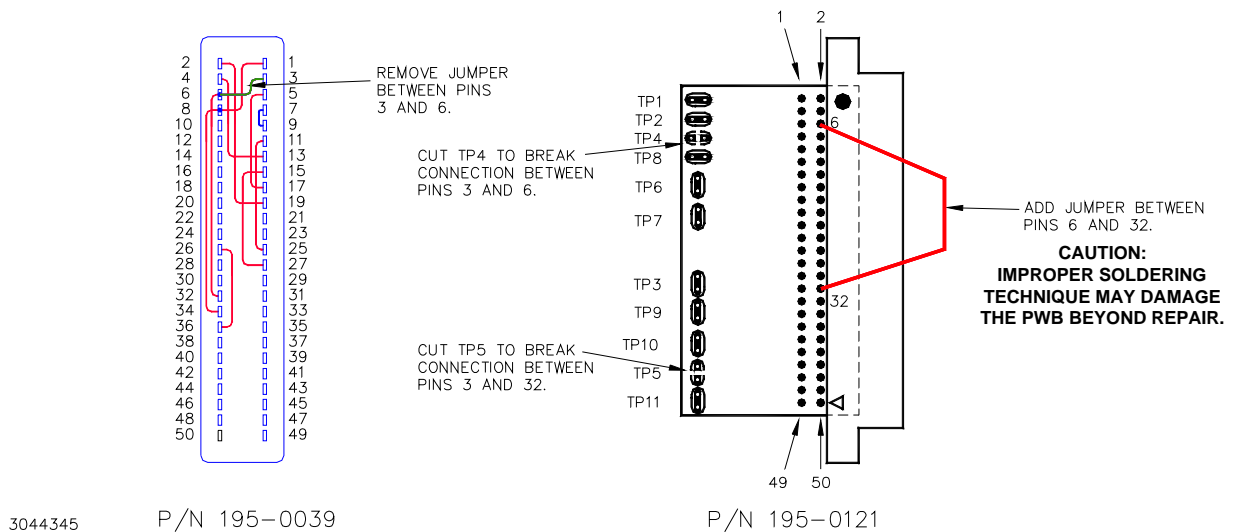

FIGURE 3-1. HOW TO MODIFY CONNECTIONS OF PC 15 REAR PROGRAMMING CONNECTOR, USING NOTE 2 OF FIGURE 3-22 AS AN EXAMPLE

3.2.4 EXTERNAL PROGRAMMING RESISTORS.

External programming resistors should be high-quality units, with low-temperature coefficients. Resistors should be selected carefully, since in most applications, the limitations for stability and drift are due not to the BOP, but to the programming resistors. Selection criteria for resistors are:

- Temperature coefficient
- Leakage (in values above 100k ohm)
- Humidity effects
- Drift with time
- Self-heating (power dissipation)
- Tolerance.

For variable resistors (potentiometers or rheostats) similar selection criteria apply. In addition, such specifications as listed below should be carefully considered if the application requires:

- End resistance
- Linearity
- Capacitive and inductive parasitic effects

3.2.5 ACTIVE PROGRAMMING SOURCES

External programming sources (Signal Generators, etc.) or reference sources should have temperature coefficients and drift specifications comparable to (or better than) the BOP Power Supply.



CAUTION: A-C source-operated programming sources must have their output isolated from the case.

3.2.6 EXTERNAL LEADS

Shielded (preferably twisted) lead pairs are recommended for all input connections to the BOP control channels. The shield should be connected (single-ended) to the chosen signal ground point. Shielded leads should be held as short as practicable. Output leads must be voltage-rated for at least the maximum BOP output voltage and current. Twisted pair wires are recommended for output power and output sense wiring.

3.2.7 EXTERNAL VOLTAGE MONITOR

Use Voltage Monitoring signal at pin 20 of the Rear Programming Connector (see Figure 3.2.4 for external voltage monitoring). The range of this signal is 0 to $\pm 10V$ equivalent to output voltage of 0 to $\pm E_{Omax}$. The Voltage Monitoring signal is buffered by an op-amp. This stage is protected against short-circuit by the intrinsic protection of the op-amp. This signal is used by the BIT card if it is installed. The return for the Voltage Monitoring signal can be any of the signal return pins (23, 25, 27, 29, 31 or 33) of the rear programming connector.

3.2.8 EXTERNAL CURRENT MONITOR

Use the Current Monitoring signal at pin 10 of the Rear Programming Connector (see Figure 3.2.4) for external current monitoring. The range of this signal is 0 to $\pm 10V$, equivalent to output current of 0 to $\pm I_{Omax}$. An op-amp buffers the Current Feedback/Sensing signal in order to create the Current Monitoring signal. This stage is protected against short-circuit by the intrinsic protection of the op-amp generating this signal. This signal is used by the BIT card if it is installed. The return for the Current Monitoring signal can be one of the signal return (signal common) pins (23, 25, 27, 29, 31 and 33) of the rear programming connector.

3.3 LOCAL (FRONT PANEL) OUTPUT CONTROL

3.3.1 VOLTAGE MODE OPERATION WITH CURRENT LIMITING.

The BOP may be used as a stabilized (d-c) source of positive or negative voltage with output current limiting (for either polarity) pre-selected for the application at hand.

Figure 3-2 illustrates the voltage control circuit configured for local (front panel) control using local sensing.

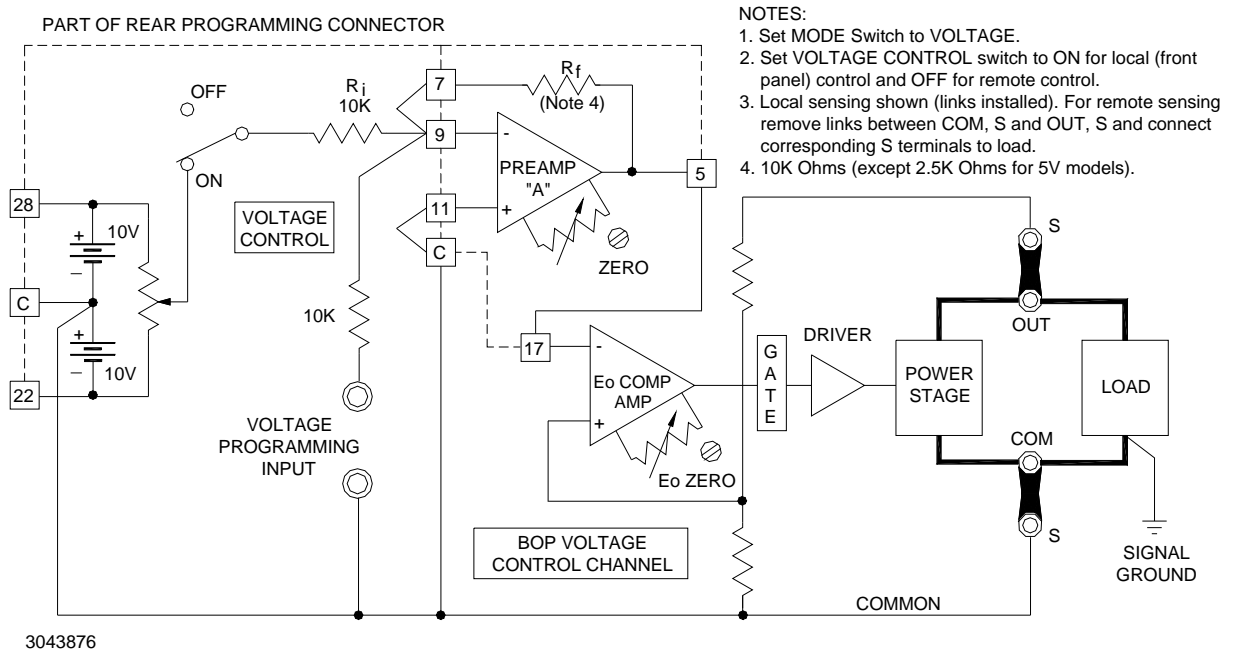

- NOTES:
1. Set MODE Switch to VOLTAGE.
 2. Set VOLTAGE CONTROL switch to ON for local (front panel) control and OFF for remote control.
 3. Local sensing shown (links installed). For remote sensing remove links between COM, S and OUT, S and connect corresponding S terminals to load.
 4. 10K Ohms (except 2.5K Ohms for 5V models).

FIGURE 3-2. BOP VOLTAGE CONTROL CHANNEL (LOCAL CONTROL, LOCAL SENSING)

Proceed as follows:

1. Determine the output voltage and current requirements of your load. Set the BOP MODE switch (8, Figure 2-1) to VOLTAGE and the VOLTAGE CONTROL switch (4) to ON.
2. With the POWER circuit breaker/switch (2) set to OFF, connect a short circuit across the output terminals and set POWER to ON again.
3. Adjust CURRENT LIMITS controls for $-I$ (18) and $+I$ (16) polarities as required, monitoring the output CURRENT meter (11) for the correct limiting value. Proceed as follows:
 - a. Turn VOLTAGE control (3) fully counterclockwise.
 - b. Adjust $-I$ CURRENT LIMITS control (18) as required.
 - c. Turn VOLTAGE control (3) fully clockwise.
 - d. Adjust the $+I$ CURRENT LIMITS control (16) as required.
 - e. Turn VOLTAGE control (3) to the center of its range.
 - f. Set POWER circuit breaker/switch to OFF; remove the short circuit from the output and reconnect the load.
4. Set POWER circuit breaker/switch to ON, and adjust VOLTAGE control (3) to the desired output voltage.

NOTE: If the output current exceeds the preadjusted value at any time, the Voltage Mode indicator (26) will go out and the CURRENT LIMITS indicator (17) will go on. After the cause of the overcurrent is eliminated, the indicators will return to their initial status.

3.3.2 LOCAL CONTROL OF CURRENT LIMITING

Figure 3-3 shows the Current Limiting circuit configured for local sensing and local (front panel) control.

The output current is sensed by the current sensing resistor R_S . The voltage drop across R_S is proportional to the output current value and is amplified by the Current Sensing amplifier and applied to the input to the (-) I_O Limit Comparison amplifier and to the (+) I_O Limit Comparison amplifier. In the local (front panel) control mode, as well as in the external control mode, a 0 to 10 volt signal, applied at the inverting inputs of the $\pm I_O$ Limit Comparison amplifiers, will control the current limit point over the entire output current range: 0.5% to 110% of nominal for local and remote control. For the internal (front panel) control mode, the control signal is derived across both 10 volt reference sources, applied by means of the $\pm I_O$ Limit controls to the internal $\pm I_O$ Limit amplifiers and directed to the respective inputs of the $\pm I_O$ Limit Comparison amplifiers. In the internal control mode, both $\pm I_O$ Limit Amplifiers (EXT) are biased off by the 15V bias source.

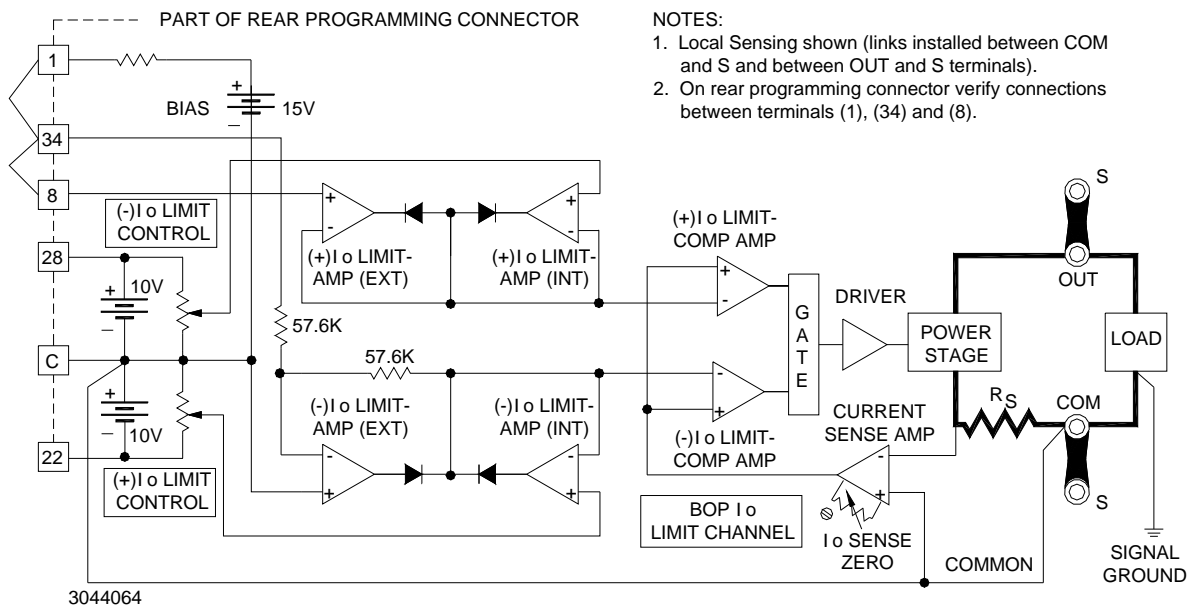
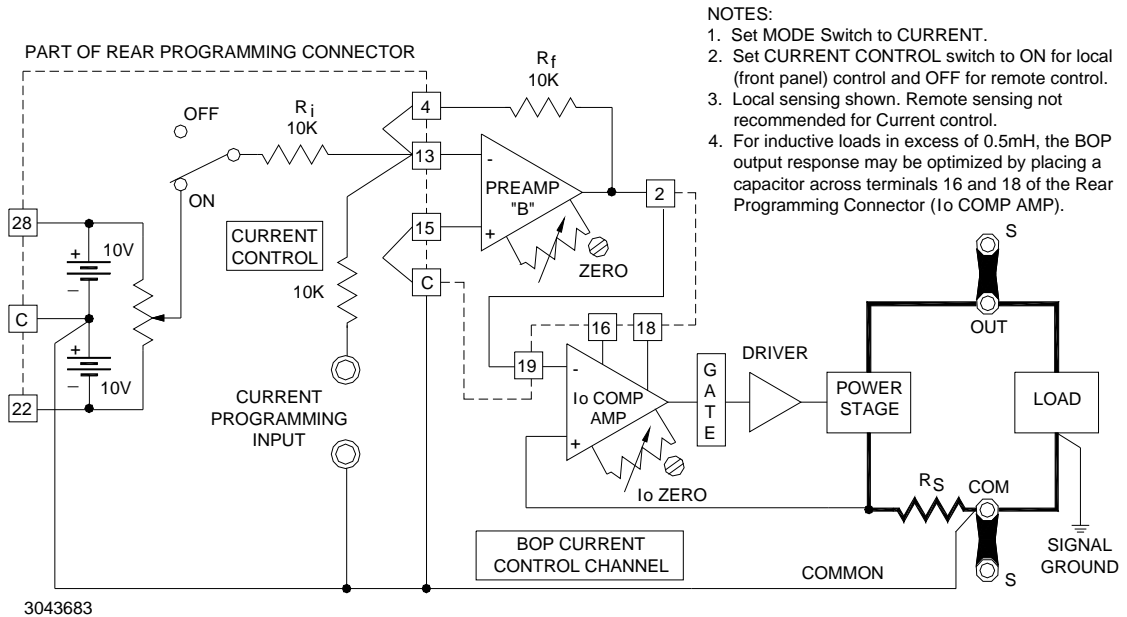

FIGURE 3-3. BOP (\pm) CURRENT LIMITING CIRCUIT (LOCAL CONTROL, LOCAL SENSING)

3.3.3 CURRENT MODE OPERATION WITH VOLTAGE LIMITING.

The BOP may be used as a stabilized d-c source of positive or negative current, with output voltage limiting (for either polarity), pre-selected for the application at hand. Figure 3-4 illustrates the current control circuit configured for local (front panel) control using local sensing.



- NOTES:
1. Set MODE Switch to CURRENT.
 2. Set CURRENT CONTROL switch to ON for local (front panel) control and OFF for remote control.
 3. Local sensing shown. Remote sensing not recommended for Current control.
 4. For inductive loads in excess of 0.5mH, the BOP output response may be optimized by placing a capacitor across terminals 16 and 18 of the Rear Programming Connector (Io COMP AMP).

FIGURE 3-4. BOP CURRENT CONTROL CHANNEL (LOCAL CONTROL, LOCAL SENSING)

With CURRENT CONTROL switch (8, Figure 2-1) set to ON (closed), and MODE switch (6) set to CURRENT, output current can be controlled by means of the CURRENT CONTROL (8) over the full output range. The control potential (zero to $\pm 10V$) is applied via Preamp "B," operating with unity gain, to the I_o Comp. Amp which drives the Power Stage with a fixed gain as listed in Table 1-3.

Proceed as follows:

1. Determine the output voltage and current requirement of your load. Set the MODE switch (6, Figure 2-1) to CURRENT and the CURRENT CONTROL switch (8) to ON.
2. With the POWER circuit breaker/switch (1) set to OFF, disconnect the load. Set the POWER circuit breaker/switch to ON again.
3. Adjust the VOLTAGE LIMITS controls for $-V$ (22) and $+V$ (20) polarities as required, monitoring output VOLTAGE meter (5) for the voltage limiting value. Proceed as follows:
 - a. Turn CURRENT CONTROL (8) fully counterclockwise.
 - b. Adjust $-V$ VOLTAGE LIMITS control (22) as required.
 - c. Turn CURRENT CONTROL (8) fully clockwise.
 - d. Adjust $+V$ VOLTAGE LIMITS control (20) as required.

- e. Turn CURRENT CONTROL (8) to the center of its range.
 - f. Set POWER circuit breaker/switch (1) to OFF and reconnect the load.
4. Set POWER circuit breaker/switch (1) to ON again, and adjust the operating current by means of CURRENT CONTROL (8) to the value required.

NOTE: If the output voltage exceeds the preadjusted value at any time the Current Mode indicator (10) will go out and the VOLTAGE LIMITS indicator will go on. After the cause of the overvoltage is eliminated, the indicators will return to their initial status.

3.3.4 LOCAL CONTROL OF VOLTAGE LIMITING

Figure 3-5 shows the Voltage Limiting circuit configured for local sensing and local (front panel) control. The circuit functions in a manner similar to the I_O Limit circuit described previously (refer to PAR. 3.3.2), except that the voltage limit feedback is derived by means of a voltage divider across the BOP output.

In the local (front panel) control mode, as well as in the external control mode, a 0 to 10 volt signal, applied at the inverting inputs of the $\pm E_O$ Limit Comparison amplifiers, will control the voltage limit point over the entire output current range of each BOP model. For the internal (front panel) control mode, the control signal is derived across both 10 volt reference sources, applied by means of the $\pm E_O$ Limit controls to the internal $\pm E_O$ Limit amplifiers and directed to the respective inputs of the $\pm E_O$ Limit Comparison amplifiers. In the internal control mode, both $\pm E_O$ Limit Amplifiers (EXT) are biased off by the 15V bias source.

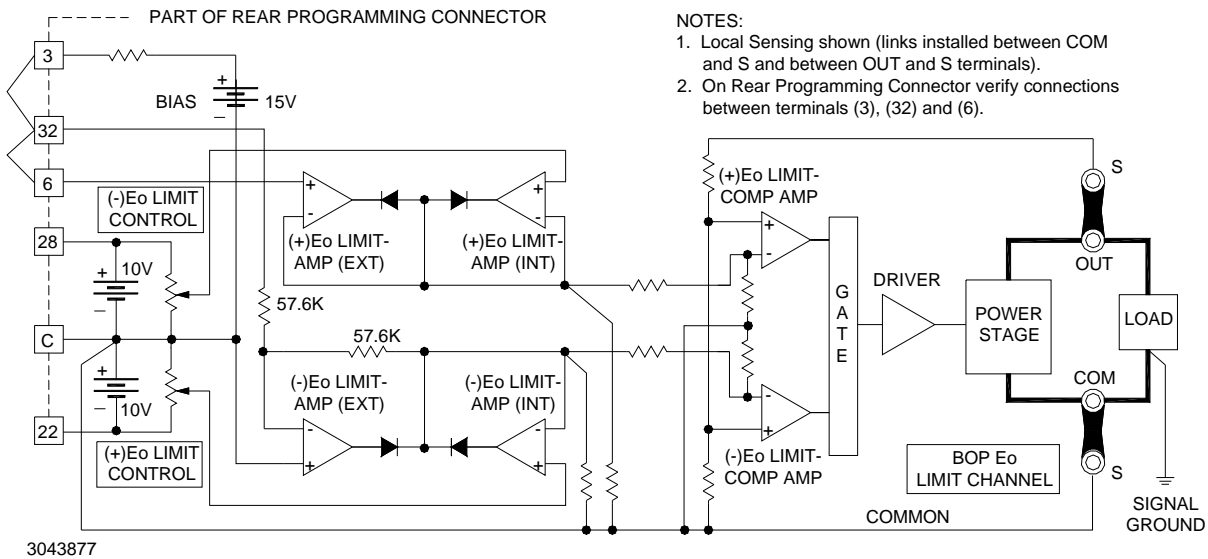

- NOTES:
1. Local Sensing shown (links installed between COM and S and between OUT and S terminals).
 2. On Rear Programming Connector verify connections between terminals (3), (32) and (6).

FIGURE 3-5. BOP (\pm) VOLTAGE LIMITING CIRCUIT (LOCAL CONTROL, LOCAL SENSING)

3.4 REMOTE CONTROL OF VOLTAGE CHANNEL

Remote control of the voltage channel is accomplished by using an external configuration to substitute for the internal control voltage produced by the front panel VOLTAGE CONTROL.

3.4.1 REMOTE VOLTAGE CONTROL USING RESISTANCE (POTENTIOMETER)

When configured as shown in Figure 3-6, Preamp "A" with the built-in feedback and input resistors has a gain of one and the fixed gain of all BOP models is designed so that a d-c input signal of zero to (\pm)10 volts will control the BOP output through its specified range. When the front panel VOLTAGE CONTROL switch (2, Figure 2-1) is set to OFF, operation is similar to local control described in PAR. 3.3.1, except that an external potentiometer is substituted for the front panel VOLTAGE control (3).

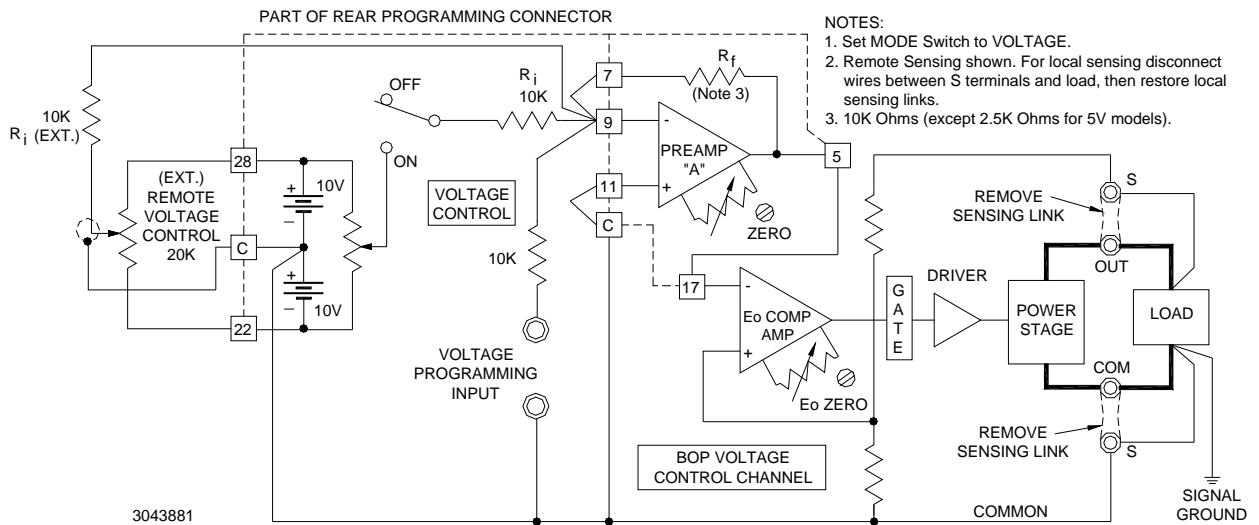

FIGURE 3-6. REMOTE POTENTIOMETER CONTROL OF D-C OUTPUT VOLTAGE

3.4.2 REMOTE VOLTAGE CONTROL USING RESISTANCE (DECADE BOX)

Two-terminal resistance control of the d-c voltage (for example, by means of a Decade Box (make-before-break type) or any variable resistance) can be exercised as shown in Figure 3-7.

The external switch (S1), connected across the (\pm) reference voltage, is used to pre-select either positive or negative output by setting it to the applicable reference voltage polarity.

PREAMP "A" functions here as an inverter. Its output can be expressed by the equation:

$$E_O (\text{PREAMP "A"}) = -E_{\text{ref}} (R_f/R_i). \text{ where}$$

R_f = Decade Resistor, 0 - 10K Ohms (except 0 - 2.5K Ohms for 5V models)

R_i = Ext. Input Resistor

The BOP output voltage will vary linearly with the change in decade resistance.

This programming system can be calibrated very accurately by setting the external Remote Voltage Control (Decade) to zero, and adjusting for zero output volts using the screwdriver-adjusted E_O ZERO control while monitoring the BOP output with a digital voltmeter. The maximum output voltage is calibrated by making all or part of R_i a rheostat and adjusting it with the Remote Voltage Control at maximum resistance, to the maximum BOP output voltage.

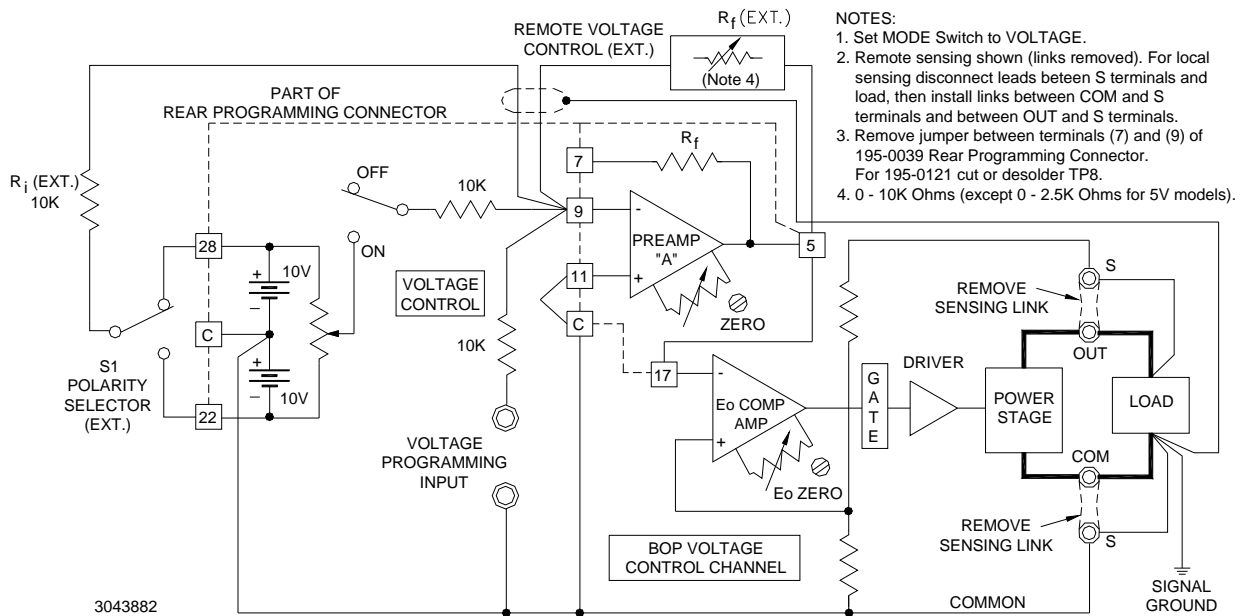

FIGURE 3-7. REMOTE D-C OUTPUT VOLTAGE CONTROL USING TWO-TERMINAL RESISTANCE (DECADE)

3.4.3 REMOTE VOLTAGE CONTROL USING D-C SIGNAL VOLTAGE

The BOP d-c output voltage can be controlled directly by a $\pm 10V$ d-c signal, applied to the front panel Voltage Programming Input terminals. An interesting example of how this can be implemented is the use of a Kepco SN Digital Programmer to convert digital input to the analog $\pm 10V$ d-c signal. The digital input to the SN programmer can be provided by a computer, or manually by means of a keyboard. The analog output from the SN is from zero to ± 10 volts and constitutes the input programming voltage for the BOP.

The connections between the SN Programmer and the BOP are illustrated in Figure 3-8. This programming system provides a resolution of 12-bits with a linearity of $(\pm)1/2$ LSB (0.0122%). The digital and the power supply grounds are isolated (optical isolation) to 1000 volts. Calibration of the system is performed with the provided controls on the SN Programmer.

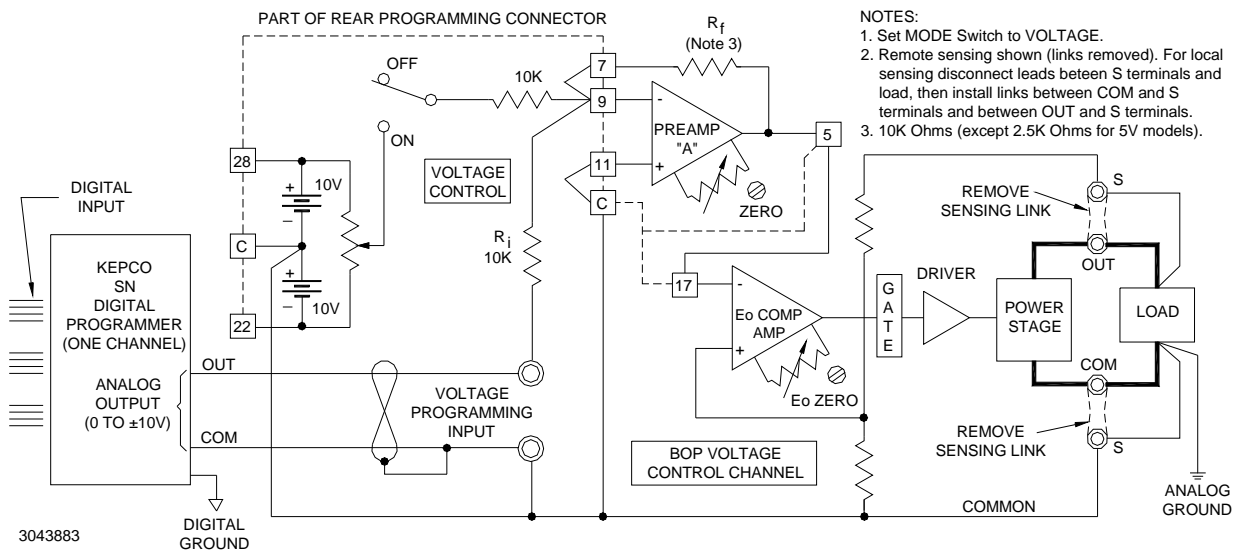

FIGURE 3-8. DIGITAL CONTROL OF THE D-C OUTPUT VOLTAGE

Since all terminals of Preamp "A" are available at the Rear Programming Connector, d-c output voltage control can be exercised in many other ways. Preamp "A" can be treated as an uncommitted operational amplifier, with its applicable transfer functions. Its initial offsets can be zeroed with the provided control. The basic principle of d-c output voltage control of the BOP is that a control voltage of $(\pm)10$ volts at 1 mA at the Voltage Programming Input (with the built-in feedback/input resistors) will produce the full d-c output voltage swing of the BOP. If the selected control signal does not have the required amplitude or if the required control current cannot be supplied, the Preamp "A" configuration can be altered to provide the proper interface for the application.

For example, if the BOP d-c output is to be controlled by means of a bipolar, 1 volt, high impedance source, it can be connected to the BOP as shown in Figure 3-9.

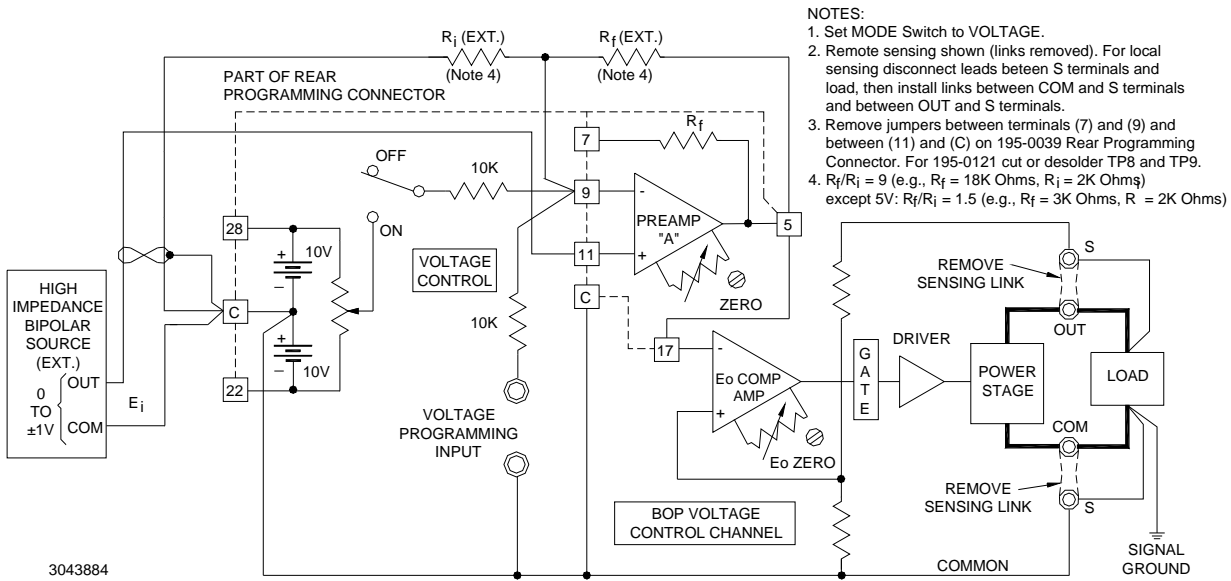

FIGURE 3-9. D-C OUTPUT VOLTAGE CONTROL WITH NON-INVERTING CONFIGURATION AND HIGH IMPEDANCE $\pm 1V$ SIGNAL SOURCE

As seen in Figure 3-9, the original input feedback components of Preamp "A" have been bypassed and are replaced by external resistors (metal film or wire-wound type resistors may be used and connected directly to the Rear Programming Connector terminals as shown). Preamp "A" is used in the non-inverting configuration, so the output voltage will have the same polarity as the input programming signal. Its output voltage (the necessary BOP control voltage) as shown in the examples below is given by:

$$E_O (\text{PREAMP "A"}) = E_i \frac{R_f + R_i}{R_i}$$

all models except 5V: $E_O (\text{PREAMP "A"}) = (\pm 1V) \frac{18K\text{Ohms} + 2K\text{Ohms}}{2K\text{Ohms}} = \pm 10V$

$$E_{O(\text{unit})} = (\pm 10V) (G) = \pm E_{O\text{nom}} (V)$$

where G = Closed loop Gain V/V (see Table 1-3)

5V models: $E_O (\text{PREAMP "A"}) = (\pm 1V) \frac{3K\text{Ohms} + 2K\text{Ohms}}{2K\text{Ohms}} = \pm 2.5V$

$$E_{O(\text{unit})} = (\pm 2.5V) (2V/V) = \pm 5V$$

Consequently, as the bipolar input voltage (E_i) is controlled from $-1V$ through zero to $+1V$, the BOP output voltage will follow over its specified range. Calibration of the system can be performed at the programming source, or the Preamp "A" ZERO (R_{41}) and E_O ZERO (R_{81}) controls can be used for the zero adjustment, while the feedback resistor (R_f) can be trimmed to calibrate full scale.

3.4.4 USING THE BOP AS A VOLTAGE AMPLIFIER

If, instead of the d-c control signal (see PAR. 3.4.3), an a-c signal voltage is applied to the Voltage Programming Input terminals, the BOP functions as a bipolar amplifier. As an amplifier, the BOP voltage gain is set on each BOP model so that (as with the d-c control signal) a bipolar a-c input signal with an amplitude of 0V to 20V (peak-to-peak) will drive the BOP output through its specified (\pm) output voltage range. All other dynamic specifications are given in Table 1-4.

The BOP can be used to amplify, sum or scale a variety of waveshapes, some of which are illustrated in Figure 3-10. All input signals are shown 180° out of phase with their corresponding output waveshapes. The latter can be readily produced in phase (i.e. with the output wave taking the same direction as the input signal) by addressing the non-inverting input of Preamp "A" instead of the front panel Voltage Programming Input terminals (inverting).

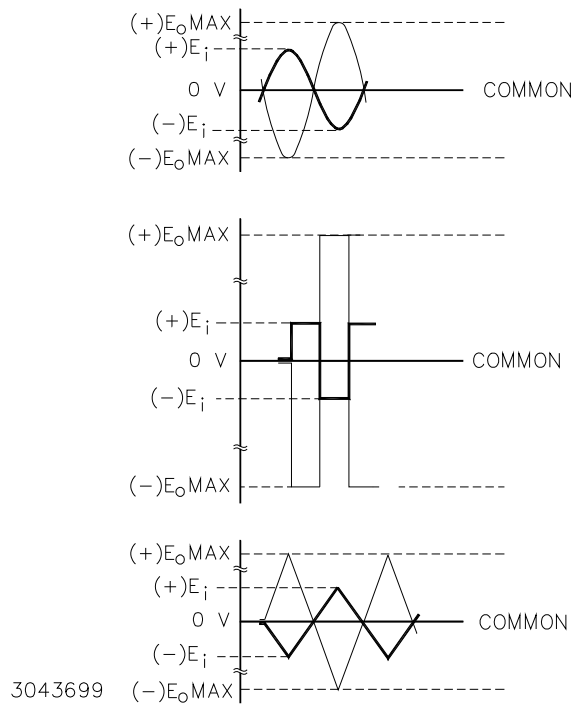
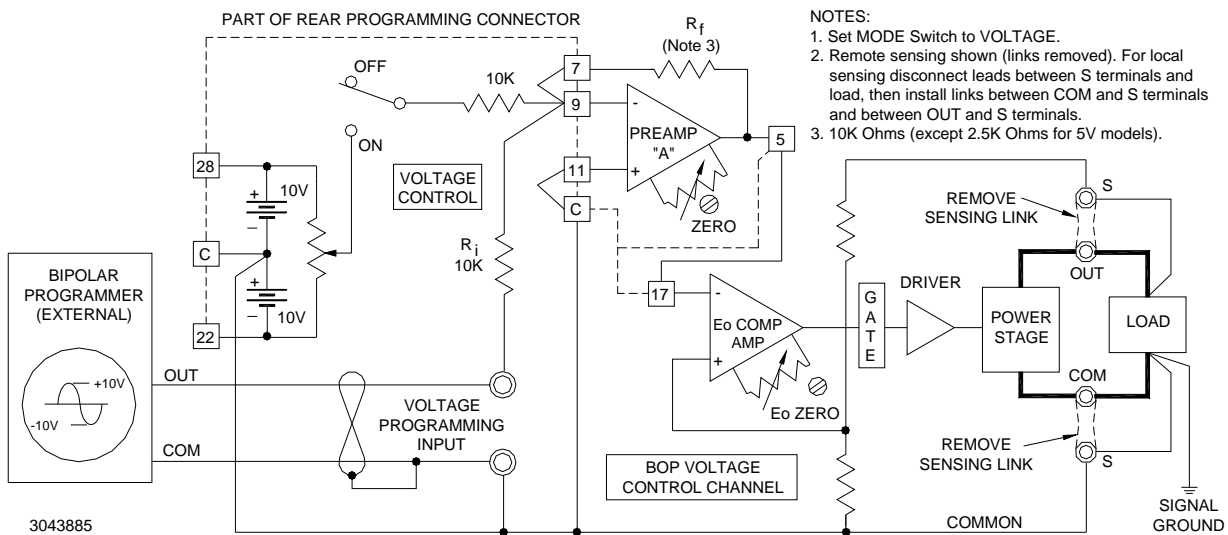

FIGURE 3-10. GRAPHS OF POSSIBLE INPUT/OUTPUT WAVESHAPES

The basic programming circuit used to produce the waveforms shown in Figure 3-10 is shown in Figure 3-11. Since all input signals of Figure 3-10 are shown with a ± 10 volts amplitude, the basic programming circuit in Figure 3-11 must be modified if the external signal source cannot produce 10 volts and if the full BOP output voltage swing is required.



- NOTES:
1. Set MODE Switch to VOLTAGE.
 2. Remote sensing shown (links removed). For local sensing disconnect leads between S terminals and load, then install links between COM and S terminals and between OUT and S terminals.
 3. 10K Ohms (except 2.5K Ohms for 5V models).

FIGURE 3-11. BASIC PROGRAMMING CIRCUIT FOR USE OF BOP AS BIPOLAR AMPLIFIER (VOLTAGE MODE)

If the external programming source does not have sufficient amplitude to drive the BOP over its full output range, the gain of Preamp "A" must be changed from the built-in value to suit the application. To calculate the required components for the new gain requirement, the output equation for Preamp "A" in the inverting configuration is used:

$$E_O (\text{PREAMP "A"}) = -E_i (R_f/R_i)$$

where E_O (Preamp "A") = $\pm 10\text{V}$ ($\pm 2.5\text{V}$ for 5V models), and the values of R_f and R_i depend on the available amplitude of the programming source. If, for example, a ± 1 volt source is available, the ratio R_f/R_i must be 10 (2.5 for 5V models), and the two resistor values can be $R_i = 10\text{K}$ and $R_f = 100\text{K}$ ($R_i = 10\text{K}$ and $R_f = 25\text{K}$ for 5V models) respectively. The built-in resistor ($R_i = 10\text{K}$) can be retained, and only R_f must be replaced with a 100K (25K for 5V models) metal film, 1/2 watt resistor. The necessary connections are illustrated in Figure 3-12. Gain control can be exercised by making R_f a rheostat instead of a fixed resistor.

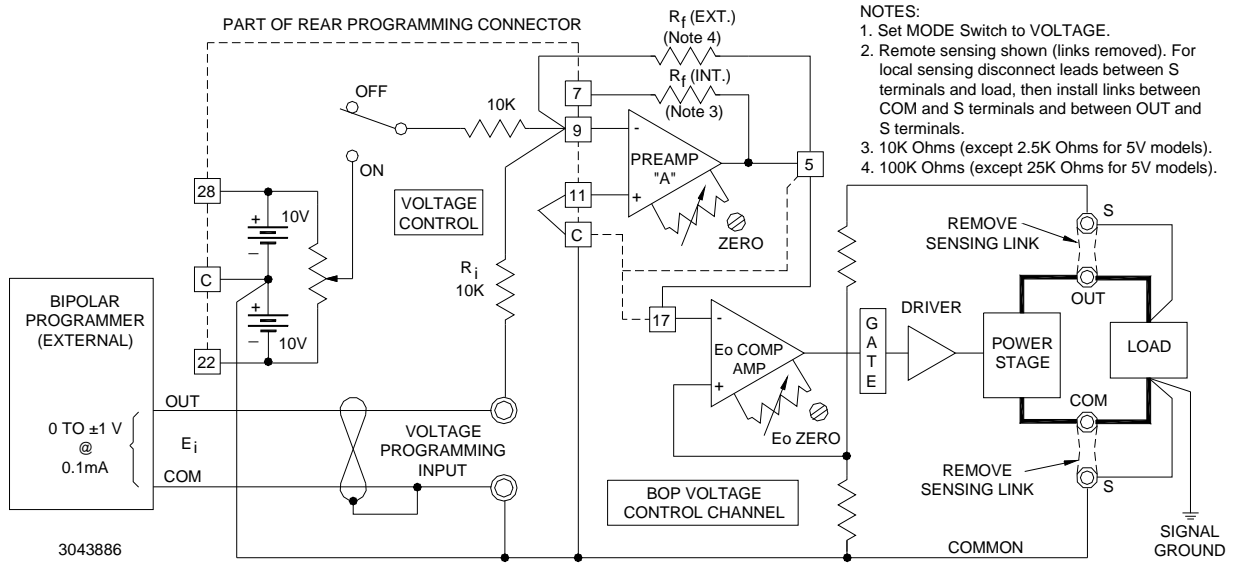

FIGURE 3-12. PROGRAMMING CIRCUIT FOR DRIVING OUTPUT VOLTAGE WITH $\pm 1V$ INPUT PROGRAMMING VOLTAGE

3.4.5 REMOTE CONTROL OF CURRENT LIMITING

For remote control of current limiting, the $\pm I_O$ Limit Amplifiers (EXT) are disconnected from the 15V Bias source by removing jumpers between (1) - (34) and (34) - (8) at the Rear Programming Connector (see Figure 3-13). An external 0 to +10V control signal is applied to terminals 8 and 34, with reference to common. This control signal programs both the negative and positive current limit simultaneously and symmetrically over the BOP output current range.

If individual control of the \pm current limits is desired, the jumper between (8) and (34) at the Rear Programming Connector must be removed and separate control sources must be connected: 0 to +10 volts to pin 8 for the $+ I_O$ limit, and 0 to +10 volts to pin 34 for the $- I_O$ limit, both with reference to common (see Figure 3-14).

NOTE: The front panel $\pm I_O$ LIMIT controls serve as a back-up when external current limit programming is used. These controls should be set to a value slightly larger than the external current limits that are to be programmed.

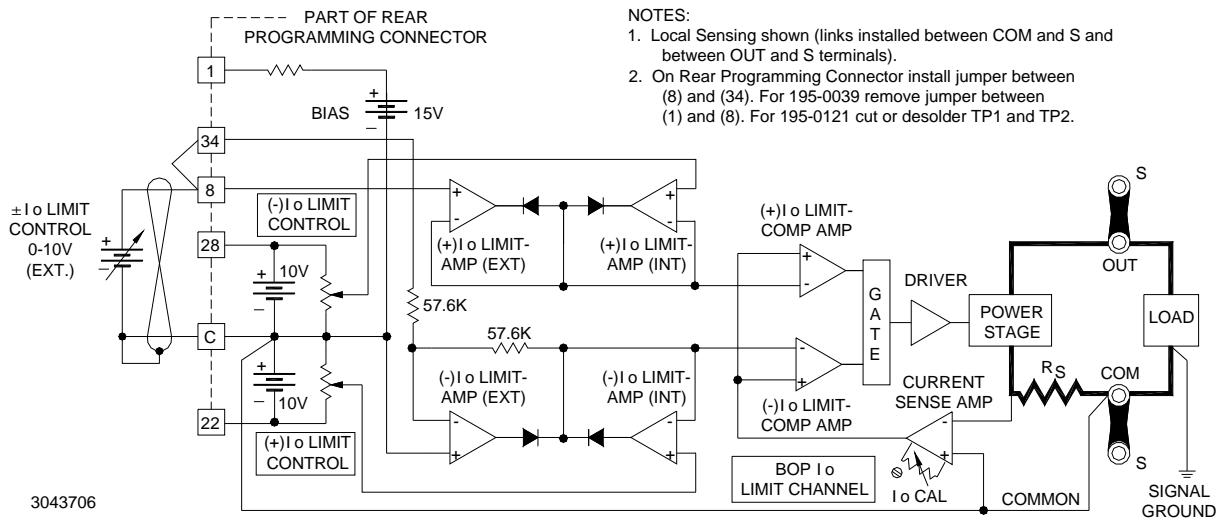

FIGURE 3-13. SYMMETRICAL REMOTE CONTROL OF THE CURRENT LIMITS

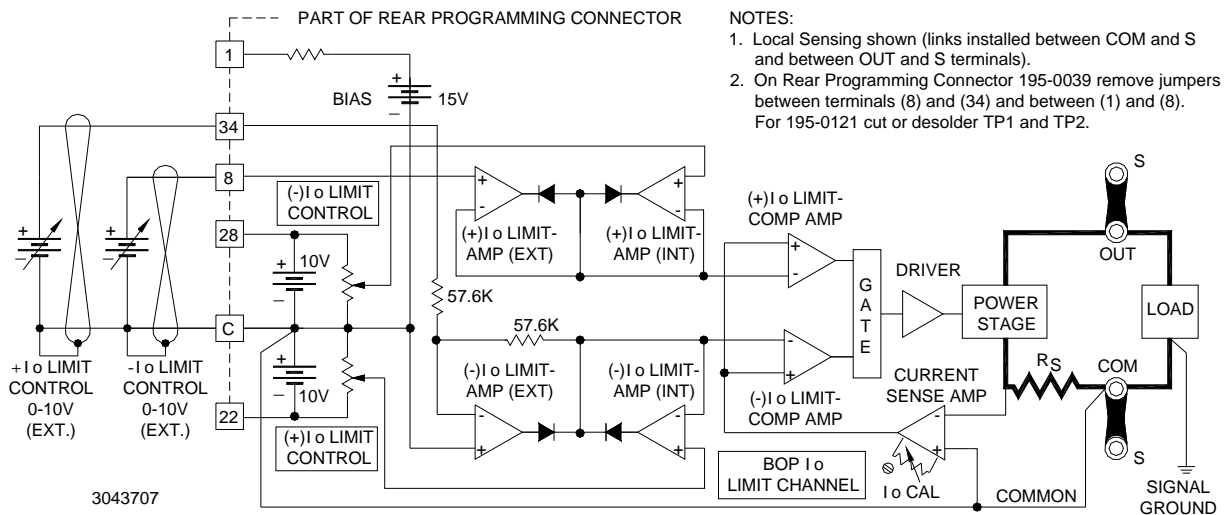

FIGURE 3-14. INDEPENDENT REMOTE CONTROL OF + I_o AND - I_o LIMITS

3.5 REMOTE CONTROL OF CURRENT CONTROL CHANNEL

Since the input signal requirements for the control of the BOP output current are the same as for programming the output voltage, and since the control circuitry of the current channel is almost identical to that of the voltage channel, all programming circuit descriptions for programming the output voltage of the BOP can be applied to current programming. The current programming circuits are illustrated in the following diagrams. Any comments specifically applicable to current channel programming are noted on the diagrams.

NOTE: Adjust the zero output current point by means of the built-in ZERO control of Preamp "B" (R42) or that of the I_o Comp. Amp (R81).

3.5.1 REMOTE CURRENT CONTROL USING RESISTANCE (POTENTIOMETER)

Similar to the local (front panel) control mode described in PAR. 3.3.3, the BOP output current can be controlled over the full output range by means of an external resistance in place of the front panel CURRENT CONTROL as shown in Figure 3-15. The control potential (zero to $\pm 10V$) is applied via Preamp "B," operating with unity gain, to the I_o Comp. Amp which drives the Power Stage with a fixed gain as listed in Table 1-3. A d-c control signal from zero to $\pm 10V$ will, therefore, control the BOP output current through its specified range.

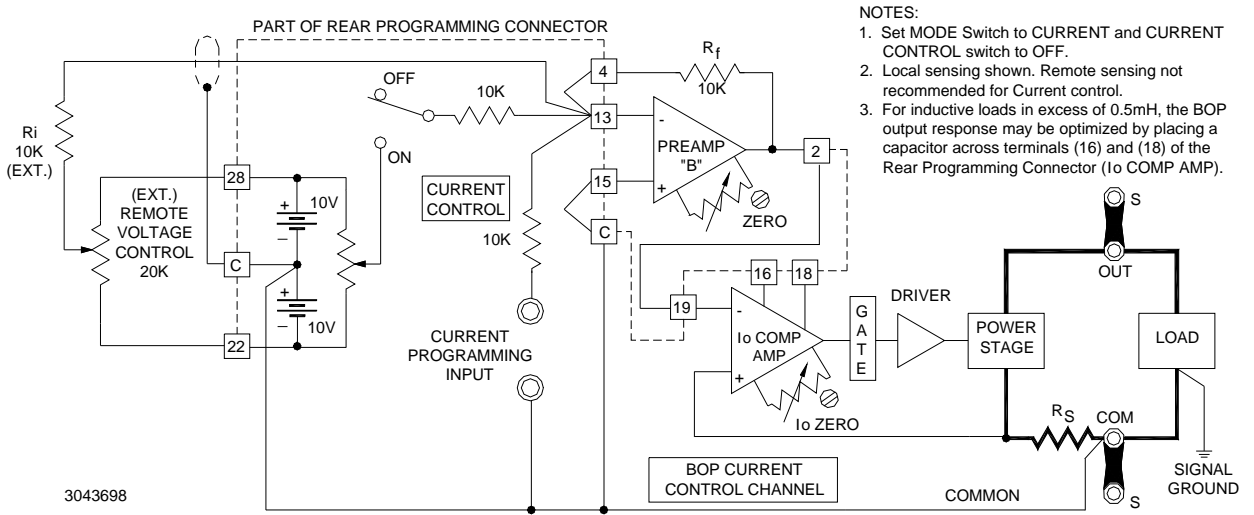

FIGURE 3-15. REMOTE POTENTIOMETER CONTROL OF THE BOP OUTPUT CURRENT

3.5.2 REMOTE CURRENT CONTROL USING RESISTANCE (DECADE BOX)

See Figure 3-16 for remote current control using a two-terminal resistance (decade box)

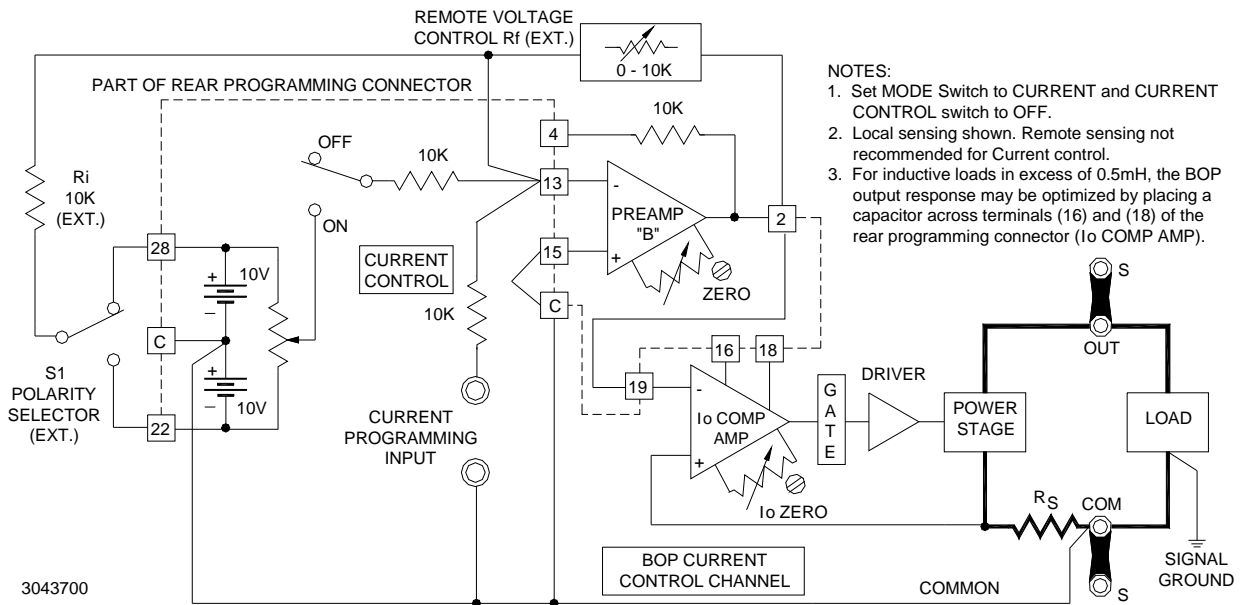
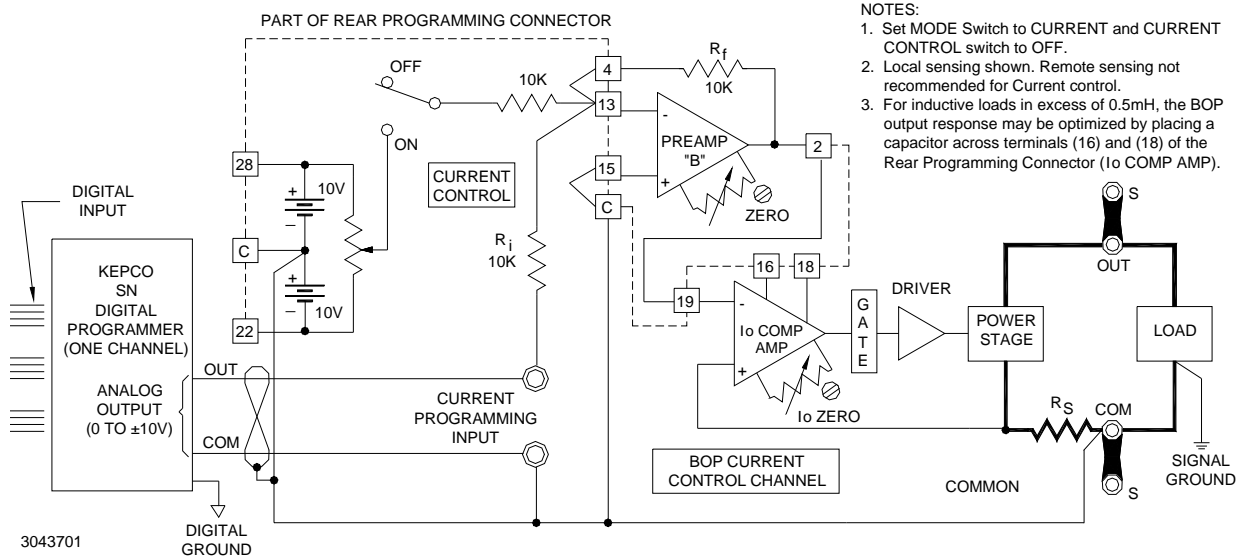

FIGURE 3-16. REMOTE D-C OUTPUT CURRENT CONTROL USING TWO-TERMINAL RESISTANCE (DECADE)

3.5.3 REMOTE CURRENT CONTROL USING D-C SIGNAL VOLTAGE

See Figure 3-17 for remote current control using a d-c signal voltage.

See Figure 3-18 for remote current control using a high impedance $\pm 1V$ voltage. Preamplifier "B" is used in the non-inverting configuration, so the output current will have the same polarity as the input programming signal.



- NOTES:
1. Set MODE Switch to CURRENT and CURRENT CONTROL switch to OFF.
 2. Local sensing shown. Remote sensing not recommended for Current control.
 3. For inductive loads in excess of 0.5mH, the BOP output response may be optimized by placing a capacitor across terminals (16) and (18) of the Rear Programming Connector (I_o COMP AMP).

FIGURE 3-17. DIGITAL CONTROL OF OUTPUT CURRENT

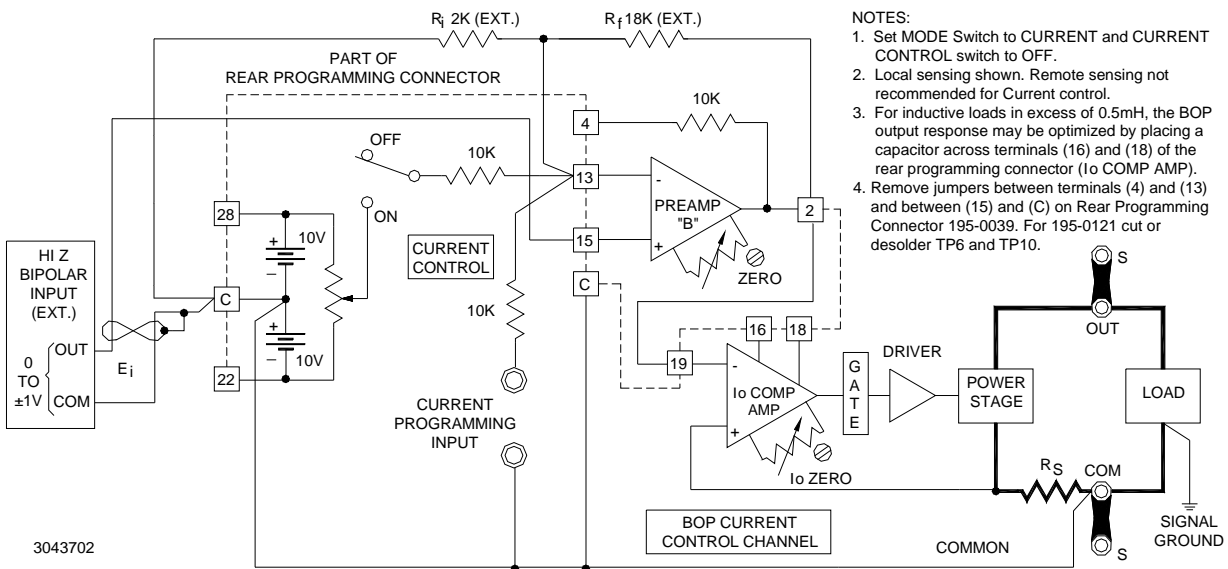

- NOTES:
1. Set MODE Switch to CURRENT and CURRENT CONTROL switch to OFF.
 2. Local sensing shown. Remote sensing not recommended for Current control.
 3. For inductive loads in excess of 0.5mH, the BOP output response may be optimized by placing a capacitor across terminals (16) and (18) of the rear programming connector (I_o COMP AMP).
 4. Remove jumpers between terminals (4) and (13) and between (15) and (C) on Rear Programming Connector 195-0039. For 195-0121 cut or desolder TP6 and TP10.

FIGURE 3-18. BOP OUTPUT CURRENT CONTROL WITH NON-INVERTING CONFIGURATION AND HIGH IMPEDANCE (± 1 VOLT SIGNAL SOURCE)

3.5.4 USING THE BOP AS A CURRENT AMPLIFIER

See Figure 3-19 to configure the BOP as a current-stabilized bipolar amplifier.

See Figure 3-20 to drive output current using a bipolar signal voltage less than $\pm 10V$.

See Figure 3-21 to drive output current using a high impedance source.

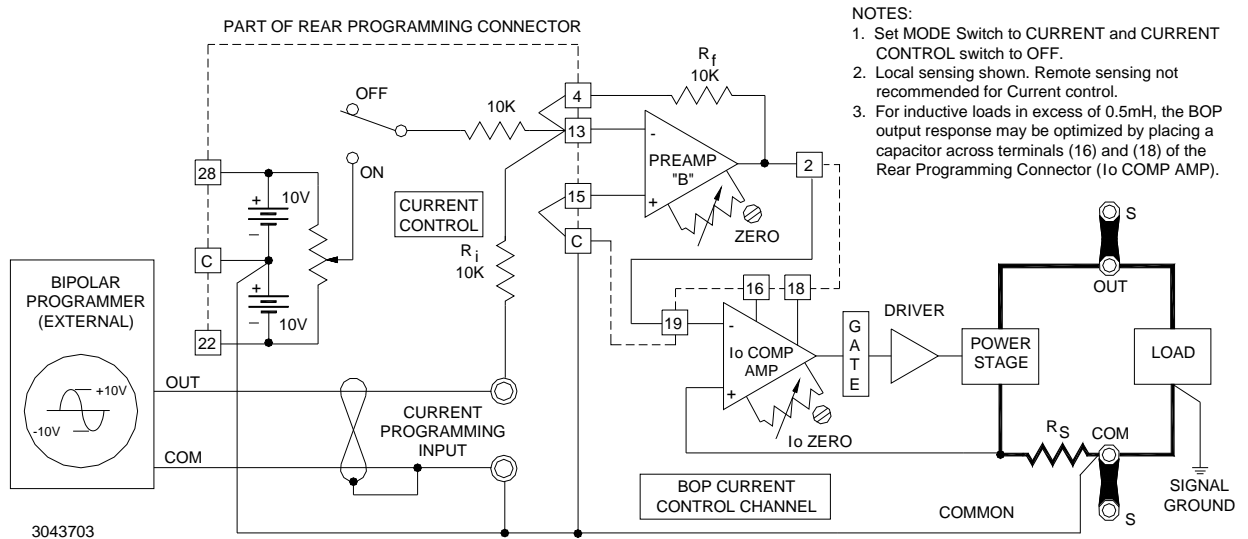

FIGURE 3-19. BASIC PROGRAMMING CIRCUIT FOR BOP AS BIPOLAR CURRENT-STABILIZED AMPLIFIER

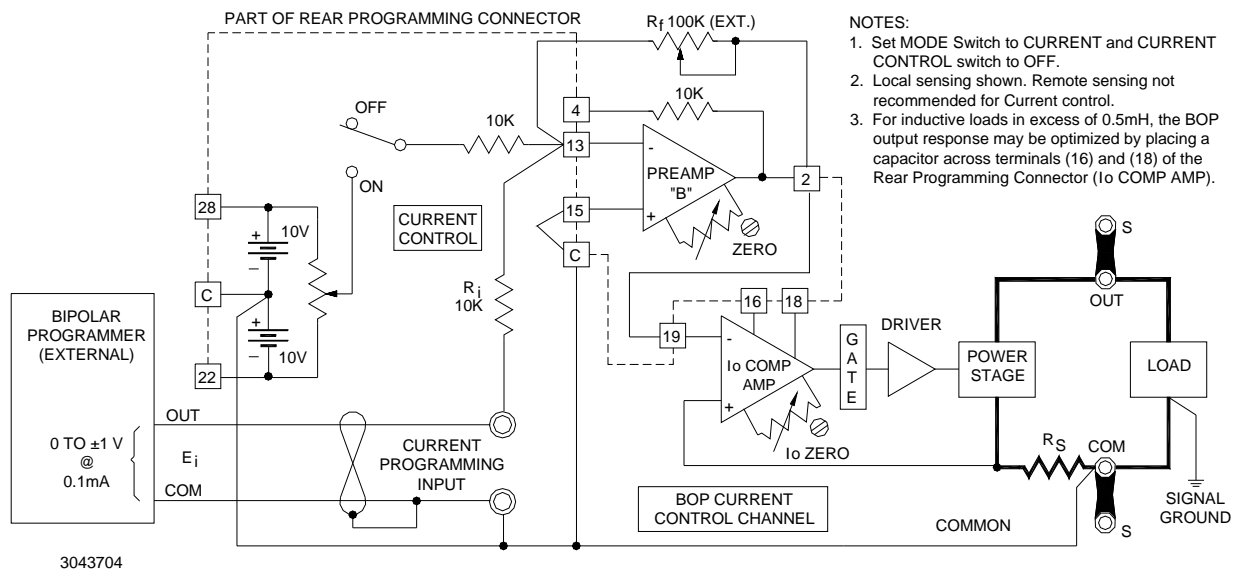

FIGURE 3-20. PROGRAMMING CIRCUIT FOR DRIVING OUTPUT CURRENT WITH $\pm 1V$ INPUT PROGRAMMING VOLTAGE

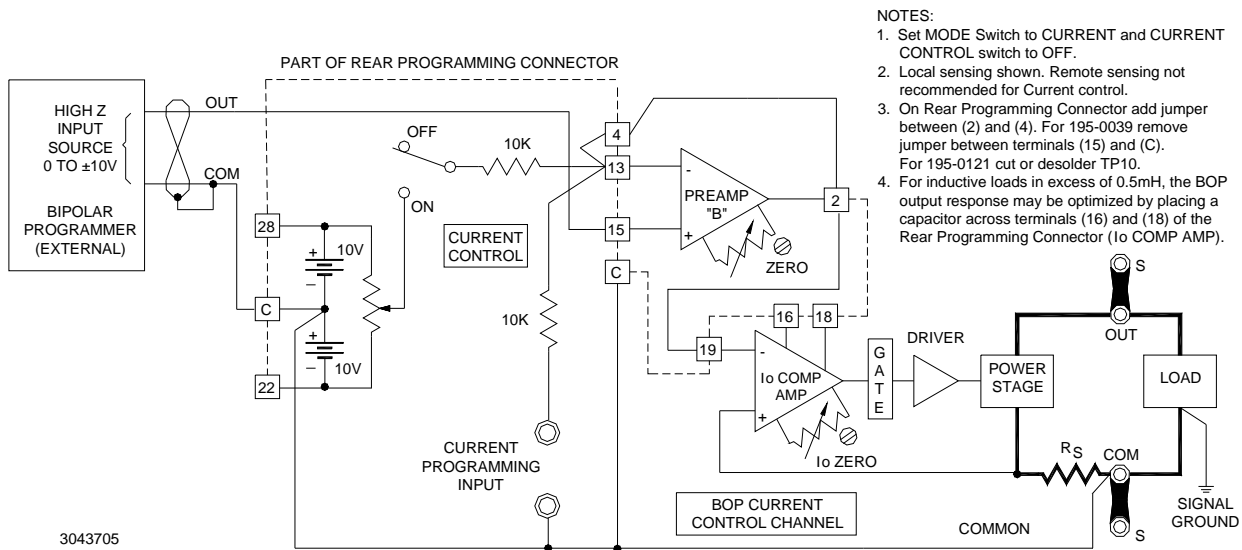

FIGURE 3-21. PROGRAMMING CIRCUIT FOR DRIVING OUTPUT CURRENT WITH A HIGH IMPEDANCE SOURCE

3.5.5 REMOTE CONTROL OF VOLTAGE LIMITING

The E_O Limit circuit can be configured to use a single external 0 to 10V d-c programming source to symmetrically control \pm Voltage Limits as shown in Figure 3-22. The circuit functions in a manner similar to the I_O Limit circuit (refer to Paragraph 3.4.5), except that the voltage limit feedback is derived by means of a voltage divider across the BOP output.

The + and - voltage limit can be controlled independently by individual 0 to 10V d-c sources, as illustrated in Figure 3-23.

NOTE: The front panel $\pm E_O$ LIMIT controls serve as a back-up when external voltage limit programming is used. The front panel VOLTAGE LIMIT CONTROLS should be set to their maximum positions if full range remote control of the BOP voltage limit is desired. For both local and remote control the voltage limit range is between 1% and 110% of the nominal voltage value.

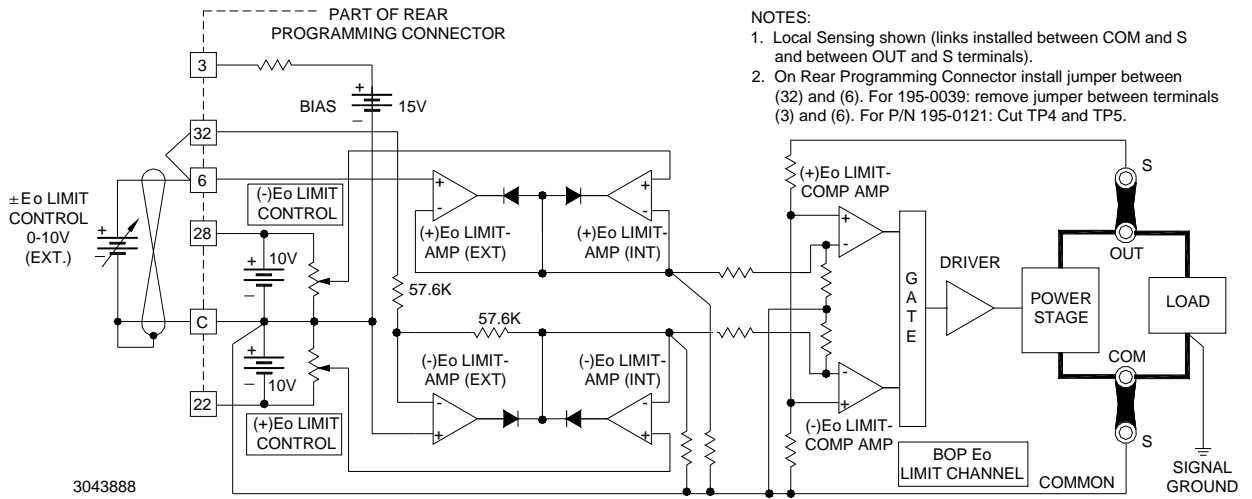

FIGURE 3-22. SYMMETRICAL REMOTE CONTROL OF VOLTAGE LIMIT

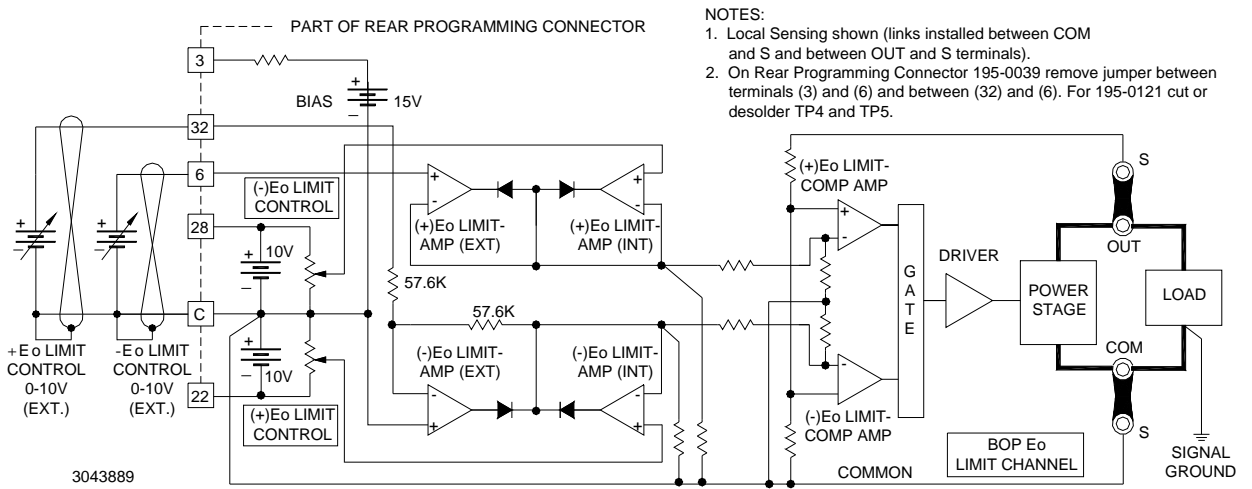

FIGURE 3-23. INDEPENDENT REMOTE CONTROL OF +E_o AND -E_o VOLTAGE LIMIT

3.6 SERIES AND PARALLEL CONNECTION OF BOP POWER SUPPLIES.

Voltage sources, such as batteries, cells or stabilized d-c power supplies can be readily series-connected, but normally they can not be paralleled. Even small differences in their terminal potential would cause large, damaging, circulating currents. By complementary reasoning, current sources can easily be paralleled, but not series-connected.

There are two basic methods which are commonly used for the series or parallel connection of stabilized d-c power supplies. The first method is the "Automatic" series or parallel connection by which the power supply outputs are simply connected together, in series or parallel, as required. The "Automatic" method presents no problems as long as it is confined to series connection with voltage sources, or to parallel connection with current sources. The proper settings for automatic series and parallel connection are as follows:

- Automatic series connection: MODE switches of all BOP to VOLTAGE. Set the CURRENT LIMIT for one BOP lower than CURRENT LIMIT for the others.
- Automatic parallel connection: MODE switches of all BOP to CURRENT. Set the VOLTAGE LIMIT for one BOP lower than VOLTAGE LIMIT for the others.

The second method for series or parallel connection of two or more units is the "Master/Slave" configuration, by which a designated Master supply controls the output of one or more Slave units. This control method permits control of the common output by a single unit - the MASTER. Since this method presents the least problems for either series or parallel connections and since it is readily implemented with BOP power supplies, it is the recommended method for this kind of operation and is described below.

3.6.1 SERIES CONNECTION, MASTER/SLAVE OPERATION



CAUTION: The following explanation is valid for analog control only. If a digital card is installed, analog control is only possible if the digital card is disabled. See application note titled "How to Disable BIT Card in a) BOP models with BIT 802E or 4886 Cards Installed or b) BOP 2X-DE Models," The application note also explains how to configure digital control of a master/slave combination. The application note can be downloaded from the Kepco web site at:

www.kepcopower.com/support/bop-app-note.htm

Three BOP power supplies can be connected in series to increase output voltage. One series-connection limitation is the isolation limit of the BOP itself (500V); contact Kepco if more than three units in series are required. The slave units are set to always be in voltage mode, adding to the output voltage of the master by repeating the master's voltage, while the master can operate in either voltage mode or current mode as needed. Figure 3-24 shows a master/slave connection of two BOP power supplies.

The BOP unit now designated the SLAVE becomes a kind of master for the next BOP unit to be added. Simply place the BOP outputs in series and connect a further coupling resistor (R_T) from the rear programming connector of the present SLAVE, terminal [C] to the new SLAVE, terminal 9. Place the MODE switch on the BOP added to the series combination to VOLTAGE and the VOLTAGE CONTROL switch OFF.

1. Connect the BOP supplies as shown in Figure 3-24. Set the MODE switches and the VOLTAGE CONTROL switches as directed in the set-up diagram, Figure 3-24.

To extend the concept of series connection to more than two BOP units, refer to FIG. 3-24. The Load-wire size should be rated to at least the maximum load current and load-wire pairs should be twisted or tied together to keep the inductance and EMI as low as possible. For remote sensing, use #22 AWG twisted pair wires.

- a. Use shielded cable for connecting the coupling resistor (R_T). Connect shield to chassis-ground. Either the positive or the negative output side of the system can be grounded.
 - b. The coupling resistor (R_T) should be either a wirewound or a metal film component with a low temperature coefficient. It is calculated by:
$$R_T \text{ (KOhms)} = (E_{OM} \text{ (MAX) Volts})/1\text{mA}$$

This value of R_T will be able to drive the BOP Slave unit to its (\pm) maximum output voltage as the BOP Master is controlled through its range.
 - c. Both BOP power supplies should be connected to the power line using a common circuit breaker. Alternatively, the BOP Circuit Breaker Control Circuit, as described in PAR. 3.6.2, can be used to interconnect both BOP's in such a way that if one of them should fail, the other one is automatically shut down also.
2. Turn BOP's on and begin operation. The system as shown in Figure 3-24 operates in Voltage Mode, since the Master MODE switch is in VOLTAGE position. For operation in Current Mode, transfer the Master MODE switch to CURRENT.

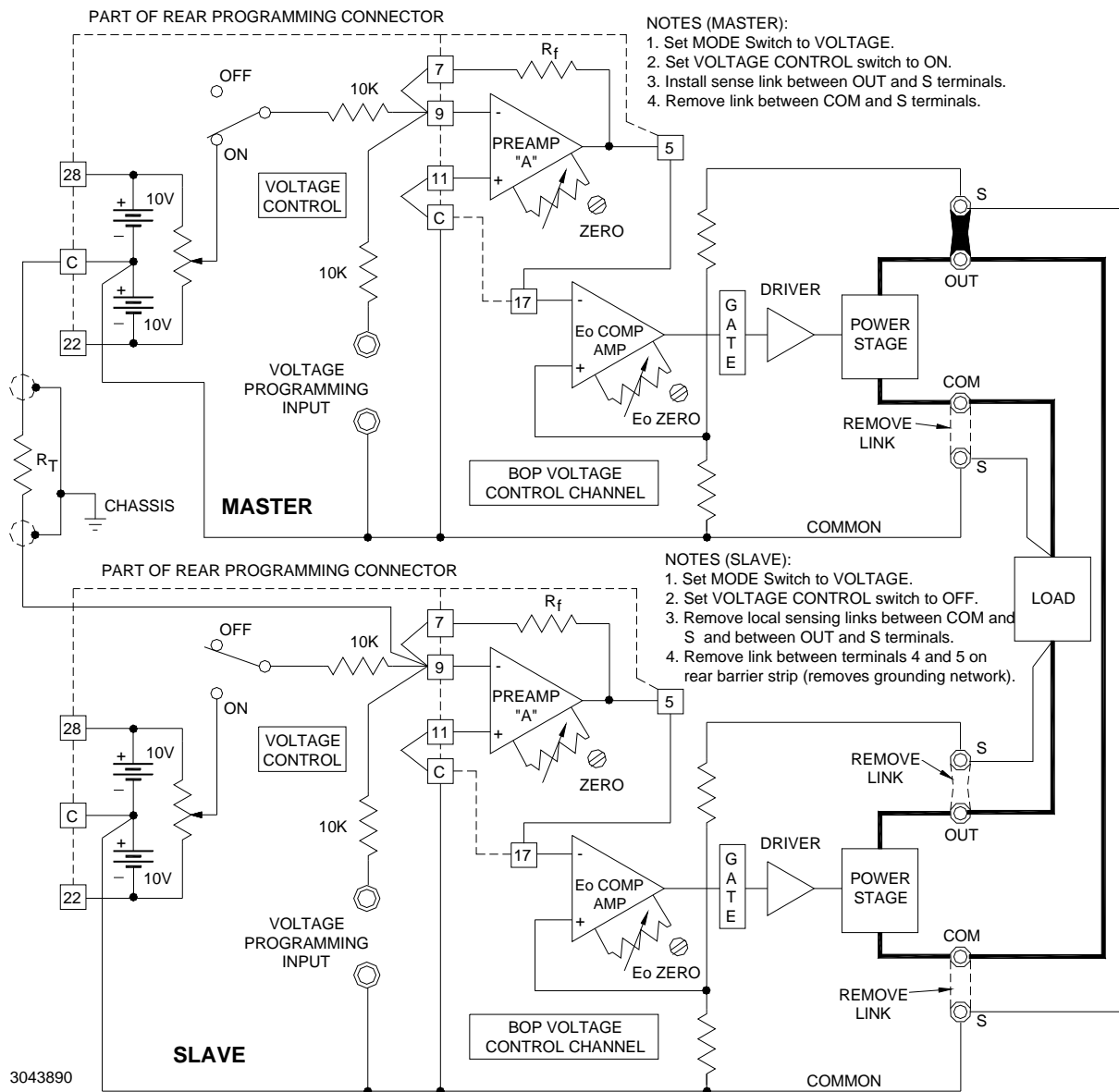

FIGURE 3-24. SERIES CONNECTION (MASTER/SLAVE) OF TWO BOP POWER SUPPLIES, WITH REMOTE ERROR SENSING AT THE COMMON LOAD

3.6.2 CIRCUIT BREAKER CONTROL CIRCUIT

The BOP is protected by the dual-coil circuit breaker/ON-OFF switch (CB101) as shown in Figure 3-25. The current sensing coil of CB101 is connected in series with the primary winding of T201, thus detecting overcurrent reflected into the primary circuit and subsequently tripping the circuit breaker. The voltage sensing coil of CB101 is connected in series with an SCR (CR4) across the driver collector supply. If the SCR is triggered on, the voltage sensing coil is energized and trips the circuit breaker. The SCR (CR4) can be triggered in several ways:

- On a-c line power loss or interruption, Q1 will loose its turn-on bias first, due to the small time-constant provided in its base circuit (not shown in the simplified block diagram). As

a result, Q2 is turned on, energizing the diode in the optical isolator (LC-1) and providing a turn-on signal for the SCR (CR4).

- In the event of an excessive heat rise on the power stage assembly, the thermal switch (S401) will close, energizing the diode in the optical isolator (LC-1) and providing thus the turn-on signal for the SCR (CR4).
- An input signal applied across terminals 49 (+) and 47 (-) of the Rear Programming Connector energizes the diode in the second optical isolator (LC-2) which, in turn, energizes the diode in the first optical isolator (LC-1), thus providing for SCR turn-on.

NOTE: Upon turn-off, an isolated output signal is available at Rear Programming Connector terminals 26 (+) and 36 (-). This output signal can be used to turn off other equipment when the BOP is turned off. As an example, applying it across terminals 49 and 47 of the Rear Programming Connector of a second BOP allows the master of a parallel or series configuration to turn off the slave when the master is turned off.

- A manual, non-isolated turn-off is provided which, when implemented with an external switch contact as shown in Figure 3-25, will energize the diode in the first optocoupler (LC-1), thus providing the SCR turn-on.
- If it is not desired to trip the circuit breaker (CB101) upon a-c line power loss, it can be prevented by a jumper wire or an external switch across terminals 24 and 25 on the Rear Programming Connector. In this manner, Q1 is inhibited from providing a turn-on signal for Q2, thus avoiding triggering the SCR and tripping the circuit breaker.

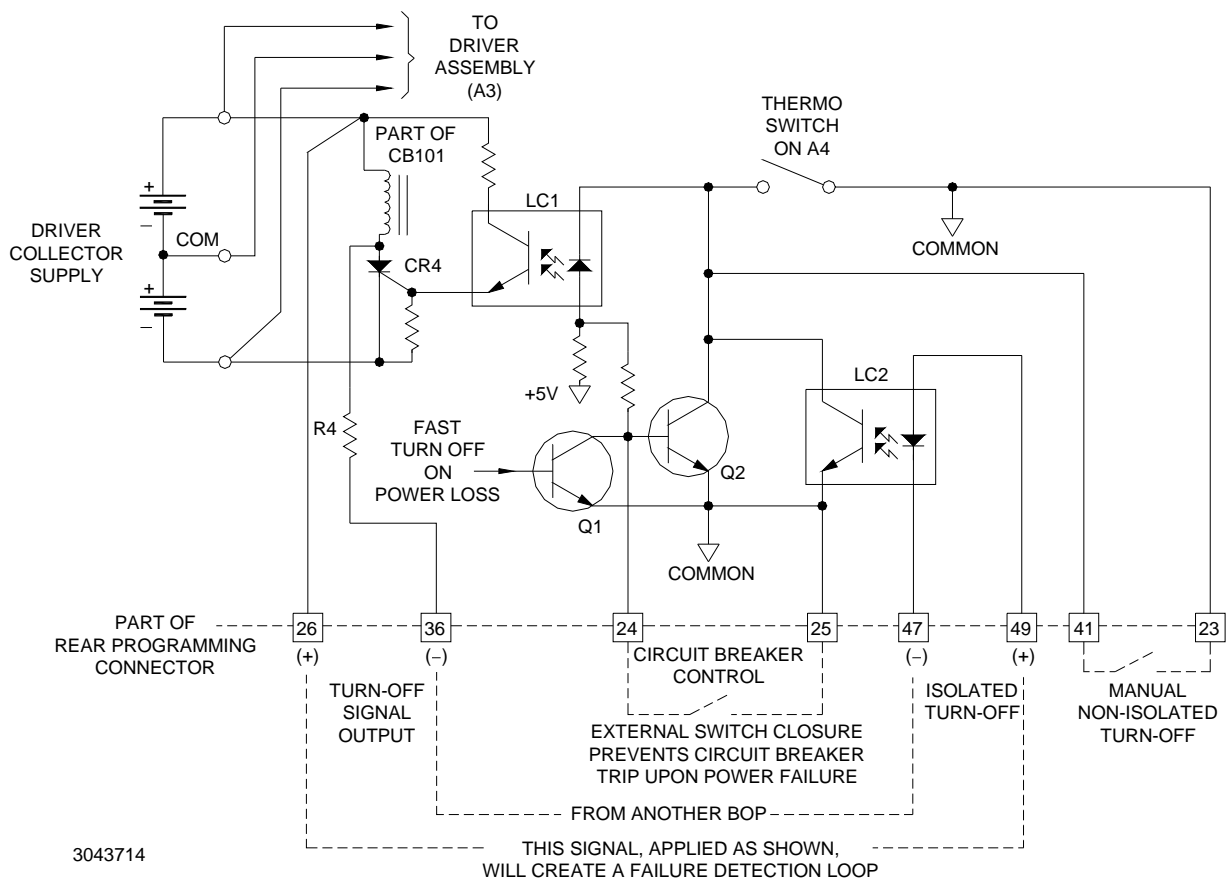

FIGURE 3-25. CIRCUIT BREAKER CONTROL CIRCUIT, SIMPLIFIED DIAGRAM.

3.6.3 PARALLEL CONNECTION, MASTER/SLAVE OPERATION



CAUTION: The following explanation is valid for analog control only. If a digital card is installed, analog control is only possible if the digital card is disabled. See application note titled "How to Disable BIT Card in a) BOP models with BIT 802E or 4886 Cards Installed or b) BOP 2X-DE Models," The application note also explains how to configure digital control of a master/slave combination. The application note can be downloaded from the Kepco web site at:

www.kepcopower.com/support/bop-app-note.htm

BOP power supplies can be connected in parallel to increase output current. One parallel-connection limitation is the load-wire size required for larger output current. The slave units are set to always be in current mode, adding to the output current of the master by repeating the master's current, while the master can operate in either voltage mode or current mode as needed. Contact Kepco if more than three units in parallel are required.

Figure 3-26 shows a simple parallel master/slave connection of no more than two BOP power supplies. The configuration shown in Figure 3-27 is more stable and accurate than that shown in Figure 3-26 since it includes compensation that eliminates the parasitic voltage drop on the COM connections of the slaves. The slave's preamplifier B is configured as a differential amplifier for the master's output current monitoring signal. Figure 3-27 is recommended for more than two units in parallel or where greater precision and stability is desired.

1. Connect the BOP supplies as shown in Figure 3-26 or 3-27 (see above for details).
 - a. Set the MODE switches and the VOLTAGE and CURRENT CONTROL switches as directed in the set-up diagram, Figure 3-26 or 3-27.
 - b. Load-wire size should be rated for at least the maximum load current and load-wire pairs should be twisted or tied together to keep the inductance and EMI as low as possible. Use shielded cable for the drive signal connection between the BOP's. Connect the shield to common ground. For remote sensing, use #22 AWG twisted pair wires.
 - c. Both BOP power supplies should be connected to the power line using a common circuit breaker. Alternatively, the BOP Circuit-Breaker Control Circuit, as described in PAR. 3.6.2 can be used to interconnect both BOPS in such a way, that if one of them should fail, the other one is automatically shut down also.
2. Following the set-up procedure as described above, turn BOP's on and commence operation. The system as shown in the set-up diagram, Figure 3-26 or 3-27, operates in the Voltage Mode, since the MASTER MODE switch is set to VOLTAGE. For operation in the current mode, set the MASTER MODE switch to CURRENT.

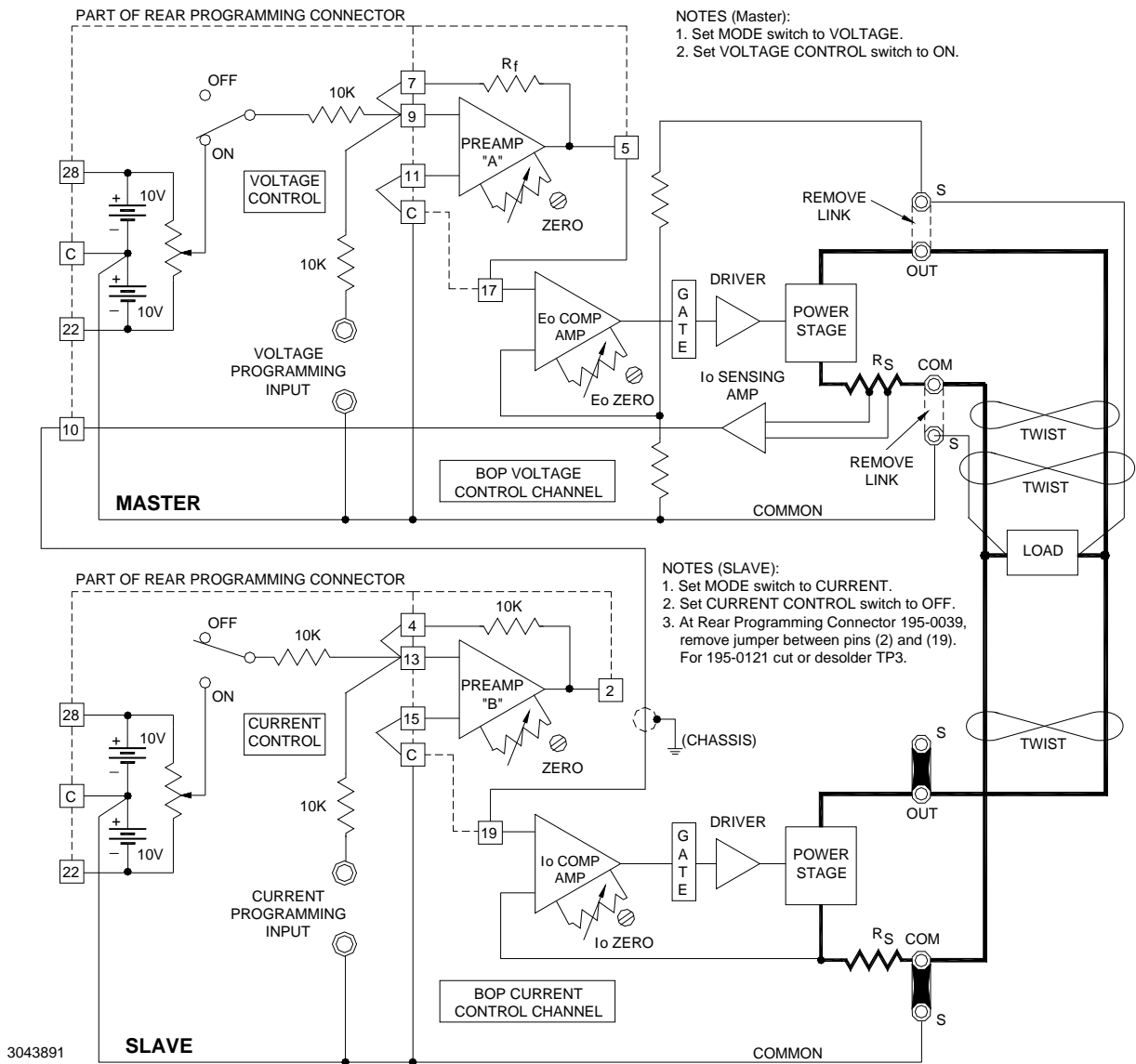

FIGURE 3-26. PARALLEL CONNECTION (MASTER/SLAVE) OF TWO BOP POWER SUPPLIES WITH REMOTE ERROR SENSING AT THE COMMON LOAD

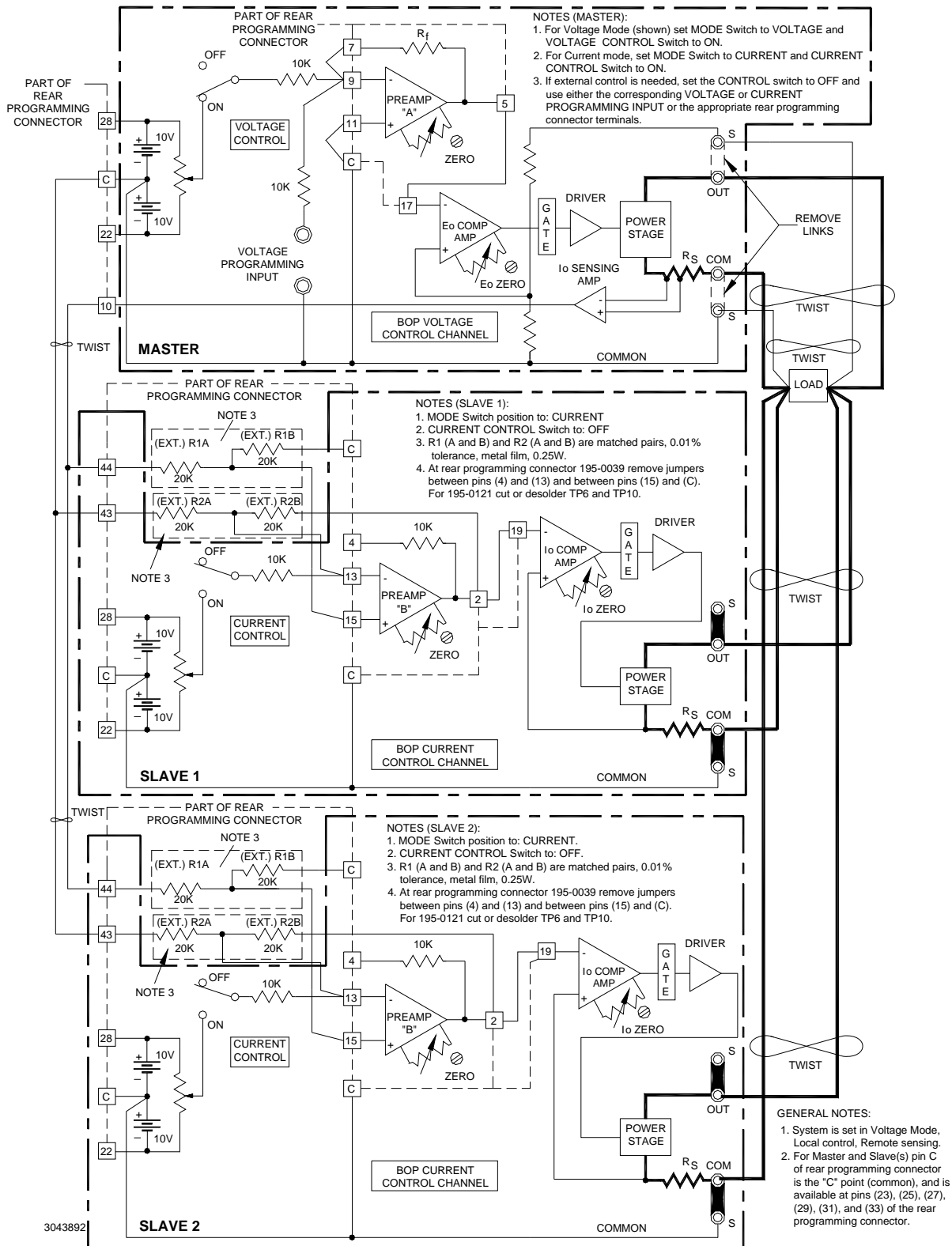

FIGURE 3-27. ALTERNATIVE PARALLEL CONNECTION (MASTER/SLAVE) FOR GREATER PRECISION AND STABILITY OF TWO OR MORE BOP POWER SUPPLIES

3.7 INDICATOR AND FLAG LOGIC CIRCUIT

Digital Logic Circuits (IC15, IC16, IC17) as shown in Figure 3-28 are used in the BOP to drive the front panel LEDs which indicate the prevailing operating mode:

- E_O LIMIT MODE (DS101)
- I_O LIMIT MODE (DS102)
- E_O MODE (DS103)
- I_O MODE (DS104)
- REMOTE (DS105)

Together with these visual front panel indicators, TTL-compatible status flags are provided at the Rear Programming Connector for the above BOP operating modes. All status flags available on the rear programming connector indicate a logic "0" if the BOP is operating in the indicated operating mode, and a logic "1" if it is not.

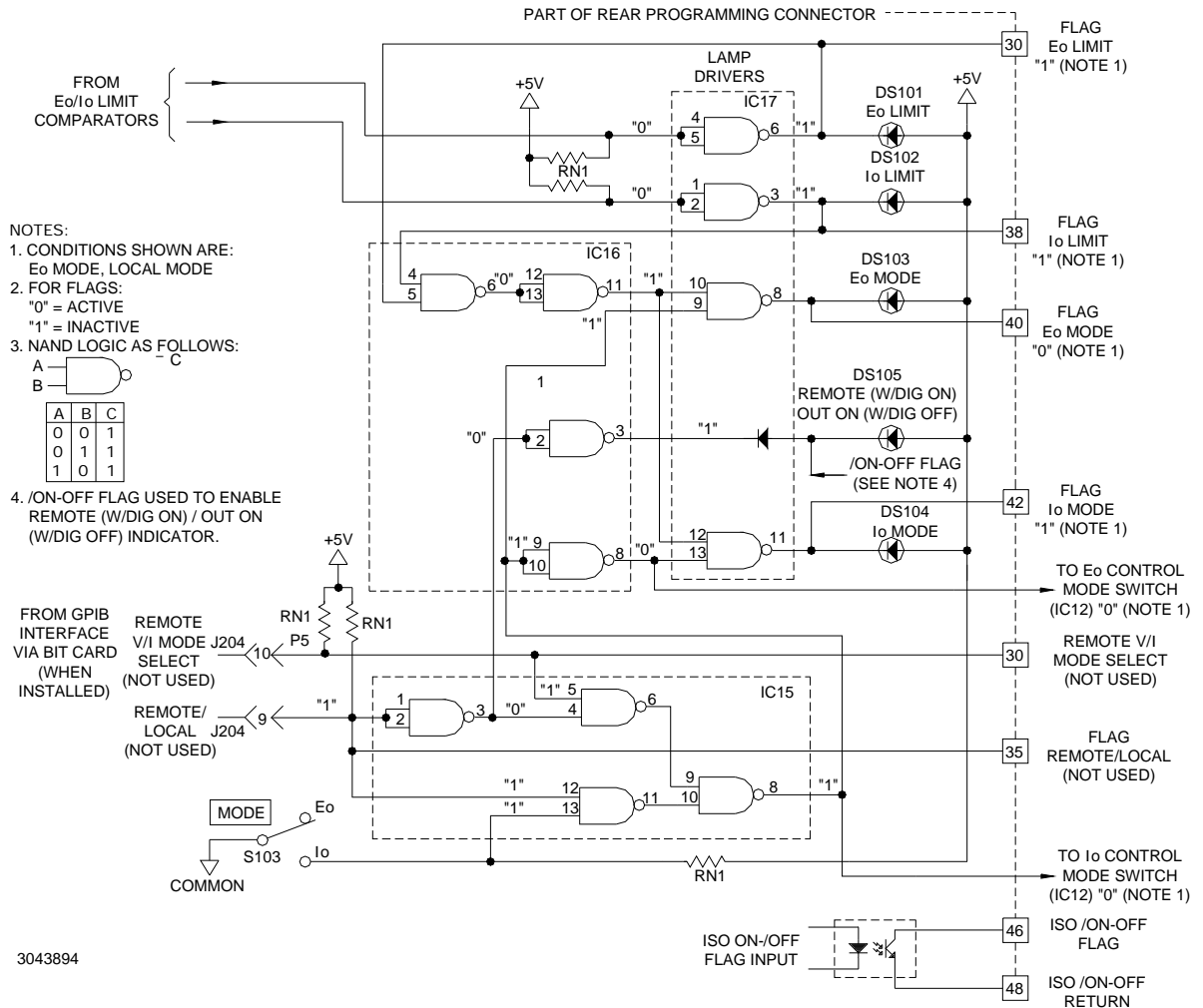

FIGURE 3-28. INDICATOR LIGHT AND FLAG LOGIC

The logic status signals shown in Figure 3-28 are valid for the BOP operating in voltage mode (E_O MODE) and local mode (not driven by the GPIB interface). The front panel REMOTE (W/DIG ON)/OUT ON (W/DIG OFF) indicator shows the output on-off status as determined by signals applied to the isolated OUTPUT ON-OFF control or to the non-isolated ON-OFF input control

3.8 DIGITAL CONTROL OF BOP POWER SUPPLIES.

The BOP is configured with a remote output ON-OFF PORT which interfaces electrically and mechanically with the digital control assembly used by a BIT Interface card which must be installed for digital control. If digital control is required, contact Kepco to order the proper BIT interface card and associated installation instructions. Digital control options available are via either GPIB and RS 232 using a BIT 4886 Interface Card, or ethernet/LAN using a BIT 802E Interface card. Both cards are compliant with IEEE 488 and SCPI commands and queries. For more details, see www.kepcopower.com/bit.htm.

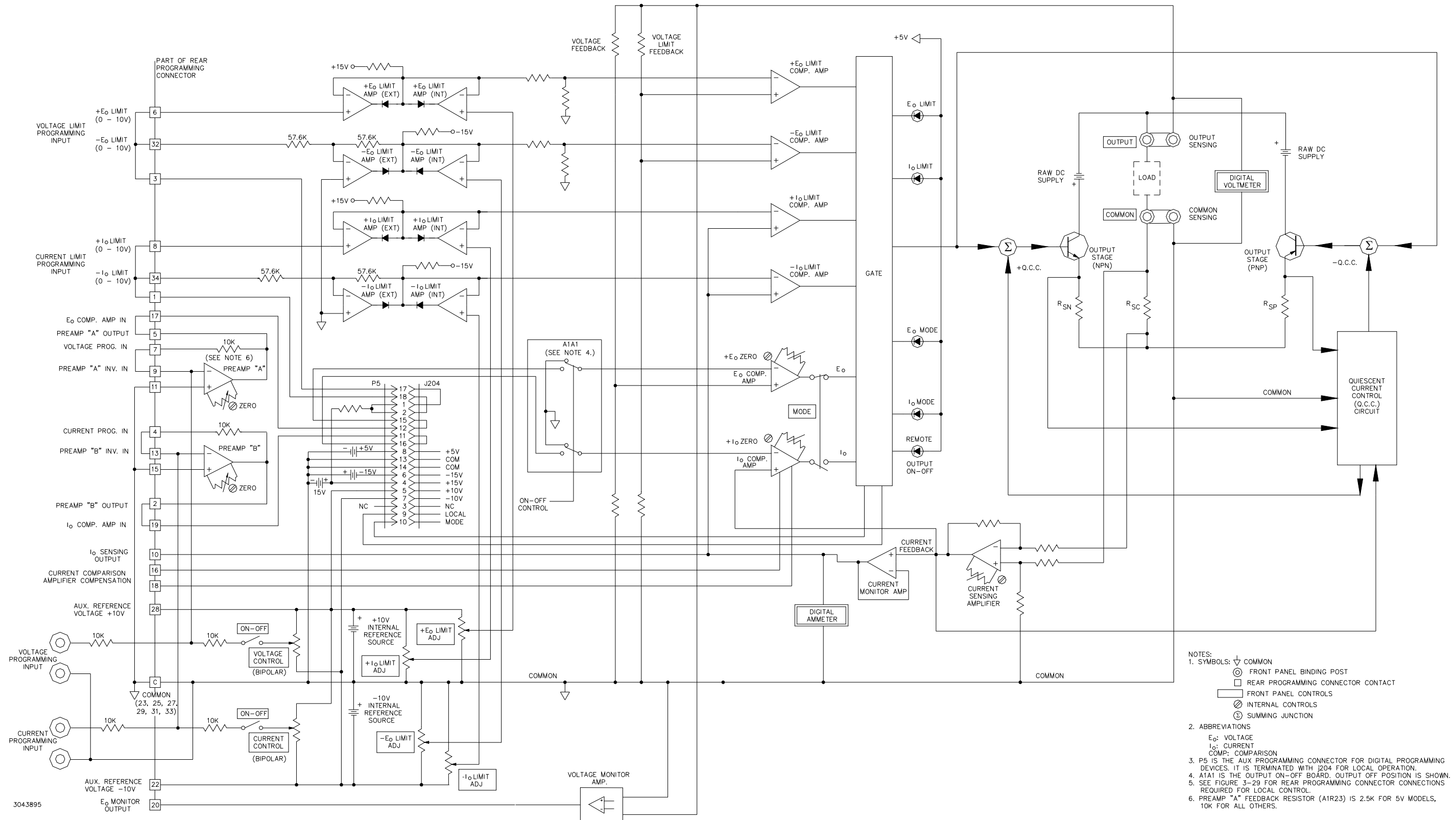
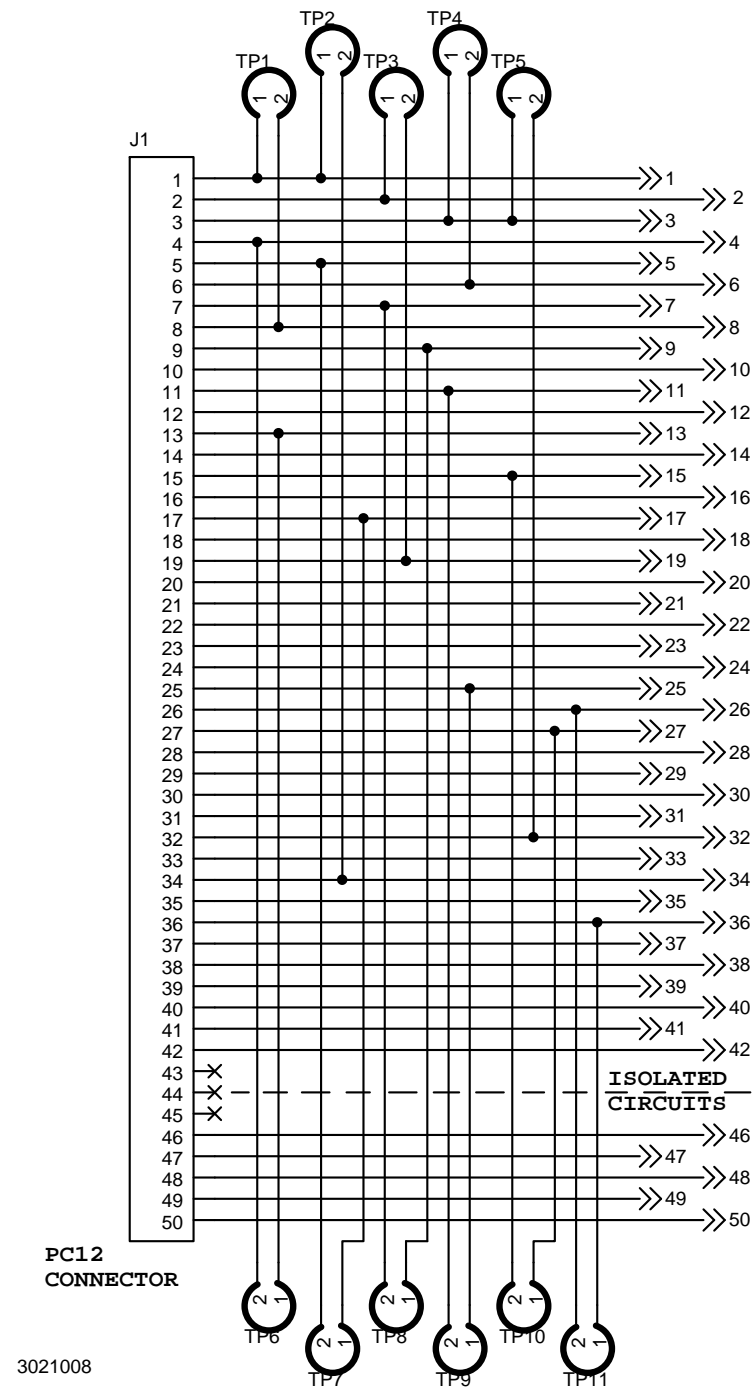

FIGURE 3-29. SIMPLIFIED SCHEMATIC DIAGRAM, BOP 100W, 200W, 400W



NOTES:

1. Connectors 195-0039 and 195-0121 both perform the same function. Connections shown are for PC 15, local control.

2. For P/N 195-0039, wires are added directly to the terminals for local control. User-added wires or components are connected directly to the terminals.

3. For P/N 195-0121 connections are made via the PWB traces and test points installed at the factory. The following table lists the pins connected when the test points are installed. For complete PWB connections, refer to the schematic diagram at the left.

TEST POINT	PINS CONNECTED WHEN TEST POINT INSTALLED	
TP1	PIN 1	PIN 8
TP2	PIN 1	PIN 34
TP3	PIN 2	PIN 19
TP4	PIN 3	PIN 6
TP5	PIN 3	PIN 32
TP6	PIN 4	PIN 13
TP7	PIN 5	PIN 17
TP8	PIN 7	PIN 9
TP9	PIN 11	PIN 25
TP10	PIN 15	PIN 27
TP11	PIN 26	PIN 36

4. For P/N 195-0121 if necessary to isolate any pins connected by a test point, cut the test point. **CAUTION: Improper soldering technique may damage the PWB beyond repair.** Holes are provided at the test points for user-added wires or components. In addition, three holes per pin are provided on the PWB for user-added wires or components.

5. PC 12 (unwired) uses connector 195-0039 for custom configurations. See PC 12 Installation Instructions for more details; available for download at www.kepcopower.com/support/opmanls.htm#pc

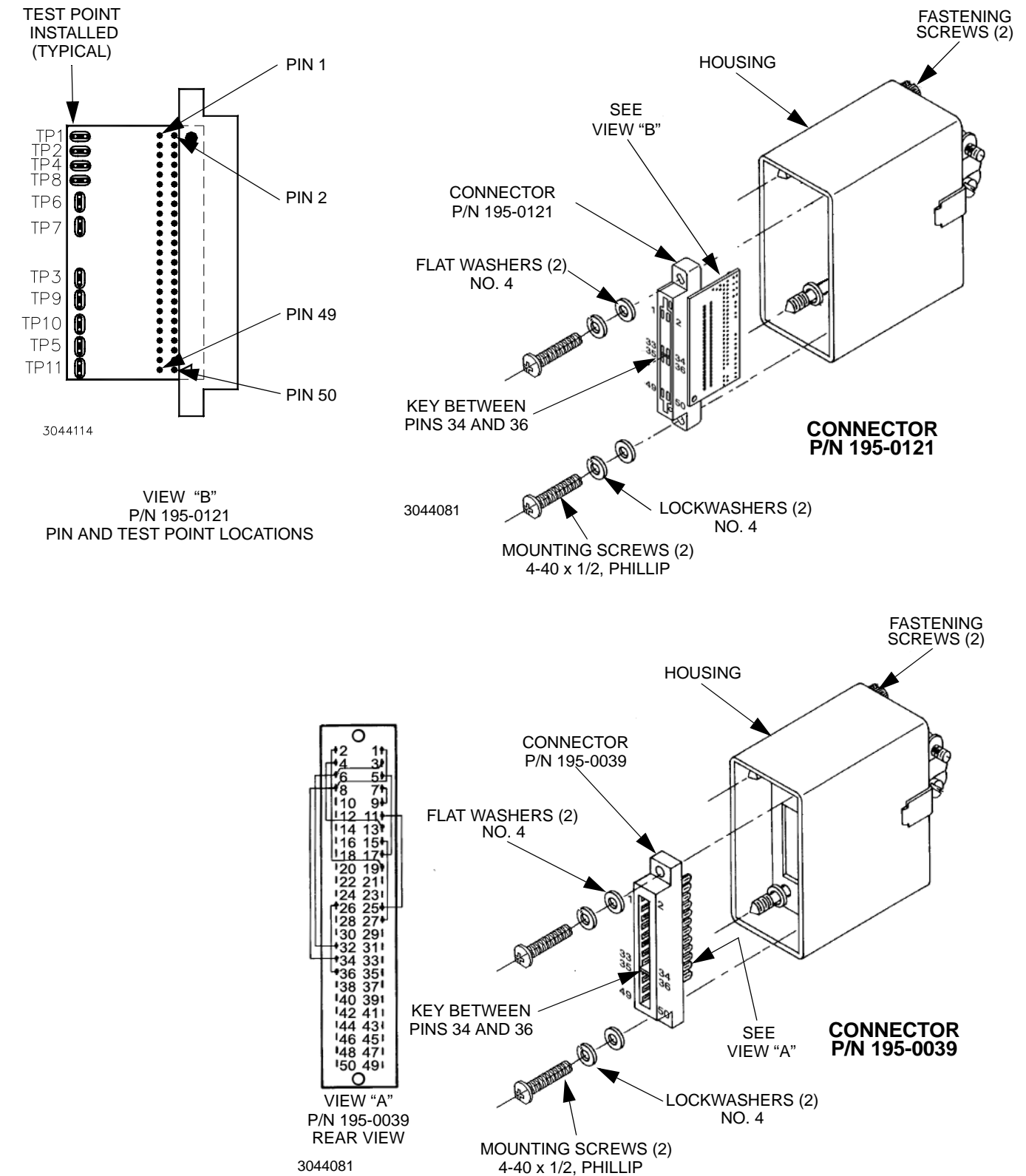

Figure 3-30. PC 15/PC 12 Rear Programming Connector Interconnections

SECTION 4 - CALIBRATION

4.1 INTRODUCTION



WARNING

Hazardous voltage is present within the unit when powered on while the cover is removed. Removal of the cover is permitted only by authorized Service personnel. Procedures and instructions found in this section are to be performed by authorized Service personnel only.

Calibration and adjustment procedures for the BOP are listed in Table 4-1. The locations of all internal controls are illustrated in Figure 4-1. Unless otherwise specified, procedures apply to both M and D suffix models as well as ML/DL and MC/DC options.

TABLE 4-1. INTERNAL ADJUSTMENTS AND CALIBRATIONS

Reference Designation	Control Name	Purpose	Adjustment Procedure																
R31, R32	±10V CAL	Reference Voltage Calibration	PAR. 4.3.1																
R41	PREAMP "A" ZERO	Uncommitted Amplifier "A" Zero Adjustment	PAR. 4.3.2																
R42	PREAMP "B" ZERO	Uncommitted Amplifier "B" Zero Adjustment	PAR. 4.3.3																
R81	E _O COMP AMP ZERO	Voltage Channel Zero Adjustment	PAR. 4.3.4																
R50	Ammeter Zero	Sensing Amplifier Offset Adjustment	PAR. 4.3.5																
R83	I _O COMP AMP ZERO	Current Channel Zero Adjustment	PAR. 4.3.6																
R316 ⁽¹⁾ (R314 on BOP 200-1) ⁽¹⁾	I _O CAL	Full Scale Output Current Calibration	PAR. 4.3.7																
R15A ⁽²⁾	Optocoupler Linearity	LC301 Optocoupler Linearization	PAR. 4.3.8																
A1R133	I _O OFF ZERO	Current Channel Zero Adjustment for OFF status	PAR. 4.3.9																
A1R136	E _O OFF ZERO	Voltage Channel Zero Adjustment for OFF status	PAR. 4.3.9																
<p>NOTES:</p> <p>(1) R316 (R314 on BOP 200-1) applies only to the following Model revision numbers (or higher):</p> <table style="width: 100%; border: none;"> <tr> <td style="width: 25%;">BOP 20-5: REV. 4</td> <td style="width: 25%;">BOP 20-10: REV. 20</td> <td style="width: 25%;">BOP 20-20: REV. 17</td> <td style="width: 25%;">BOP 36-6: REV. 20</td> </tr> <tr> <td>BOP 36-12: REV. 16</td> <td>BOP 50-2: REV. 23</td> <td>BOP 50-4: REV. 15</td> <td>BOP 50-8: REV. 13</td> </tr> <tr> <td>BOP 72-3: REV. 12</td> <td>BOP 72-6: REV. 15</td> <td>BOP 100-1: REV. 26</td> <td>BOP 100-2: REV. 17</td> </tr> <tr> <td>BOP 100-4: REV. 16</td> <td>BOP 200-1: REV. 10</td> <td></td> <td></td> </tr> </table> <p>(2) R15A for Model BOP 200-1 only.</p>				BOP 20-5: REV. 4	BOP 20-10: REV. 20	BOP 20-20: REV. 17	BOP 36-6: REV. 20	BOP 36-12: REV. 16	BOP 50-2: REV. 23	BOP 50-4: REV. 15	BOP 50-8: REV. 13	BOP 72-3: REV. 12	BOP 72-6: REV. 15	BOP 100-1: REV. 26	BOP 100-2: REV. 17	BOP 100-4: REV. 16	BOP 200-1: REV. 10		
BOP 20-5: REV. 4	BOP 20-10: REV. 20	BOP 20-20: REV. 17	BOP 36-6: REV. 20																
BOP 36-12: REV. 16	BOP 50-2: REV. 23	BOP 50-4: REV. 15	BOP 50-8: REV. 13																
BOP 72-3: REV. 12	BOP 72-6: REV. 15	BOP 100-1: REV. 26	BOP 100-2: REV. 17																
BOP 100-4: REV. 16	BOP 200-1: REV. 10																		

3044358

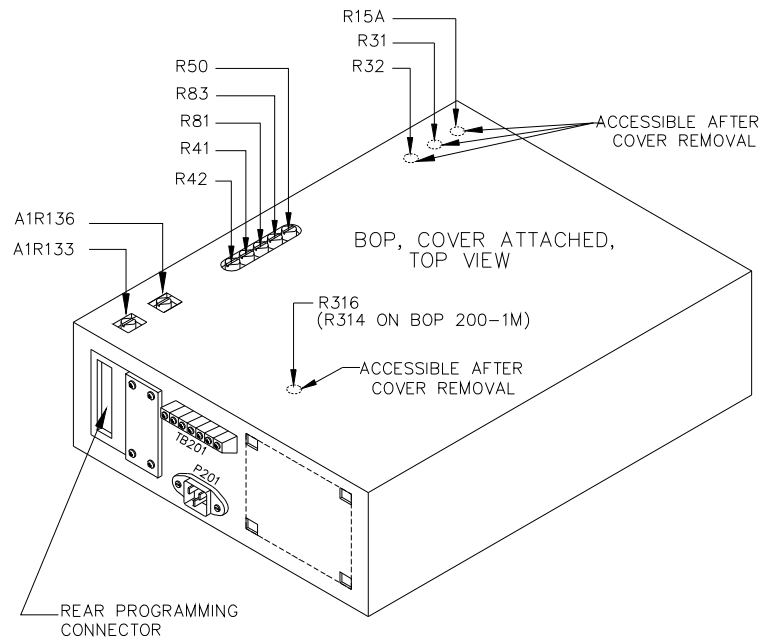

NOTE: See PAR. 3.2.3 and Figure 3-30 for Rear Programming Connector details.

FIGURE 4-1. LOCATIONS OF ADJUSTMENT AND CALIBRATION CONTROLS

4.2 TEST EQUIPMENT REQUIREMENTS

Table 4-2 lists sense resistors recommended for measuring current and includes Kepco and Manufacturer's part numbers. The value of the sense resistor chosen should be known with 0.001% accuracy. If other than a recommended sense resistor is to be used, it must be rated for at least 100W power dissipation (actual power dissipation will be less than 10W). The thermal coefficient of the sense resistor chosen should be 10 ppm/°C or better.

The digital voltmeter (DVM) used to measure output voltage and the voltage across the current sensing resistor should have at least six digits, multiple ranges, the smallest resolution must be at least one microvolt and the accuracy must be at least 0.0001%.

An oscilloscope and function generator capable of supplying a 20V p-p, 250Hz triangular wave is needed to adjust optocoupler linearity of BOP 200-1 (PAR. 4.3.8).

Adjustable resistive load is needed to adjust optocoupler linearity of BOP 200-1 (PAR. 4.3.8).

To calibrate the external programming capabilities of the BOP a DC reference voltage with the following minimum specifications is required.

- Value: 0.0V \pm 0.1mV and 10.0V \pm 0.1mV (either positive and negative or floating)
- Stability: better than 10⁻⁵
- Internal Impedance: better than 0.1 Ohms
- Output Current: >0.5mA when sourcing, >0.15mA when sinking

TABLE 4-2. SUGGESTED SENSE RESISTORS

MODEL	VALUE	KEPCO PART NO.	MANUFACTURER	MANUFACTURER PART NO.
BOP 5-20 BOP 5-30 BOP 20-5 BOP 20-10 BOP 20-20 BOP 36-6 BOP36-12	0.001 OHM	115-3033	ISOTEK	RUG-Z-R001-0.1 TK10
BOP 50-2 BOP 50-4 BOP 72-3 BOP 72-6 BOP100-1 BOP 100-2 BOP 100-4 BOP 200-1	0.01 OHM	115-2997	ISOTEK	RUG-Z-R010-0.1 TK10
NOTE: Selected sense resistor must be mounted on a heatsink with a minimum surface area of 36 square inches to maintain thermal stability during calibration; forced cooling is recommended. Kepco Heatsink P/N 136-0451 will provide adequate cooling for the sense resistor.				

4.3 INTERNAL ADJUSTMENTS AND CALIBRATIONS

See Figure 4-1 for location of adjustment controls. For complete calibration of the unit it is recommended that the adjustments be done in the order presented.



NOTES: 1. These controls are factory calibrated. Recalibration is necessary only if components related to the circuitry involving these controls have been replaced or if there are indications that the unit is out of calibration.

2. Before using the BOP in any application, please refer to Section 2 to get acquainted with the operating controls, a-c power requirements and information on load connections and grounding.

3. The Rear Programming Connector must be installed at all times.

4.3.1 ADJUSTMENT OF ±10 VOLT CALIBRATION CONTROLS (R31, R32)

1. Turn BOP off and disconnect it from source power. Then remove the BOP cover.
Full Rack models: 9 screws on each side, 1 screw at front, 1 screw on top
3/4 Rack models: 5 screws on each side. 1 screw on top
2. With the BOP powered off connect a DVM (see PAR. 4.2) to the Rear Programming Connector from COMMON (pin 23, 25, 27, 29, 31 or 33) to pin 28 (+10V) and subsequently to pin 22 (-10V).
3. Locate the calibrating controls R31 (+10V) and R32 (-10V). See Figure 4-1 for location. Turn on BOP.
4. First adjust R31 control to +10 Volts ±0.1mV on the digital voltmeter.
5. Move the DVM from pin 28 of the Rear Programming connector to pin 22 and adjust R32 to -10V ±0.1mV.
6. Turn off BOP.

4.3.2 PREAMPLIFIER "A" ZERO (R41)

1. Before adjusting Preamplifier "A" Zero control, turn BOP off and configure the preamplifier: set amplification factor as desired, either inverting or non-inverting,

NOTE: Whenever Preamplifier "A" configuration is changed, this Zero control R41 should be readjusted

2. Without a load connected to the BOP output, place a short circuit across the input of Preamplifier "A." For the default inverting configuration the short circuit is placed across the VOLTAGE PROGRAMMING INPUT terminals (24, Figure 2-1) on the front panel.
3. Set BOP to Voltage Mode (MODE switch, 6, Figure 2-1 to VOLTAGE position) with VOLTAGE CONTROL switch (2, Figure 2-1) to OFF position.
4. Connect the DVM to the Rear Programming Connector from COMMON (pin 23, 25, 27, 29, 31 or 33) to pin 5.
5. Locate the Preamplifier "A" Zero control R41 (see Figure 4-1).
6. Turn on BOP and adjust R41 for $0V \pm 0.1mV$ on the DVM.
7. Turn off BOP.

4.3.3 PREAMPLIFIER "B" ZERO (R42)

1. Before adjusting Preamplifier "B" Zero control, turn BOP off and configure the preamplifier: set amplification factor as desired, either inverting or non-inverting,

NOTE: Whenever Preamplifier "B" configuration is changed, this Zero control R42 should be readjusted

2. Without a load connected to the BOP output, place a short circuit across the input of Preamplifier "B." For the default inverting configuration the short circuit is placed across the CURRENT PROGRAMMING INPUT terminals (11, Figure 2-1) on the front panel.
3. Set BOP to Voltage Mode (MODE switch, 6, Figure 2-1 to VOLTAGE position) with VOLTAGE CONTROL switch (2, Figure 2-1) to OFF position.
4. Connect the DVM to the Rear Programming Connector from COMMON (pin 23, 25, 27, 29, 31 or 33) to pin 2.
5. Locate the Preamplifier "B" Zero control R42 (see Figure 4-1).
6. Turn on BOP and adjust R42 for $0V \pm 0.1mV$ on the DVM.
7. Turn off BOP.

4.3.4 VOLTAGE CHANNEL ZERO ADJUSTMENT (R81)

1. Turn off BOP. Without a load connected to the BOP output, connect a digital voltmeter to terminal 1 (OUTPUT SENSE) of TB 201 on the rear panel (2, Figure 2-2), with DVM return to TB 201 terminal 6 (COMMON SENSE).
2. Set BOP to Voltage Mode (MODE switch, 6, Figure 2-1 to VOLTAGE position) with VOLTAGE CONTROL switch (2, Figure 2-1) to OFF position.
3. Place a short circuit across the VOLTAGE PROGRAMMING INPUT terminals (24, Figure 2-1) on the front panel.
4. Turn BOP on and locate the Voltage Channel Zero Adjustment (R81, see Figure 4-1).
5. Adjust R81 for output voltage of $0V \pm (0.00001 \times E_{O\text{nom}})$ where $E_{O\text{nom}}$ is the nominal (rated) output voltage of the BOP (in Volts). So, e.g., for BOP 50-4 the tolerance is $0.00001 \times 50 = \pm 0.0005V$.
6. Turn off BOP.

4.3.5 AMMETER ZERO CONTROL ADJUSTMENT (R50)

1. Without a load connected to the BOP output, connect a digital voltmeter to the Rear Programming Connector from COMMON to pin 10.
2. Set BOP to Voltage Mode (MODE switch, 6, Figure 2-1 to VOLTAGE position) with VOLTAGE CONTROL switch (2, Figure 2-1) to OFF position.
3. Locate AMMETER ZERO control (R50, see Figure 4-1) and turn BOP on.
4. Adjust R50 control to 0 Volts $\pm 0.1\text{mV}$ on the digital voltmeter.

4.3.6 CURRENT CHANNEL ZERO ADJUSTMENT (R83)

1. Turn off BOP. Without a load connected to the BOP output, connect a precision 4-terminal current sensing shunt resistor (see Table 4-2) across the OUTPUT and COMMON terminals at either the front (16 and 18, Figure 2-1) or rear panel (terminals 2 and 5), Figure 2-2).
2. Connect the DVM to the shunt's sensing terminals.
3. Set BOP to Current Mode (MODE switch, 6, Figure 2-1 to CURRENT position) with CURRENT CONTROL switch (9, Figure 2-1) to OFF position.
4. Place a short circuit across the CURRENT PROGRAMMING INPUT terminals (11, Figure 2-1) on the front panel.
5. Locate Current Channel Zero Adjustment (R83, see Figure 4-1) and turn BOP on.
6. Adjust R83 for output voltage of $0V \pm (0.0001 \times I_{O\text{nom}} \times R_S)V$ where $I_{O\text{nom}}$ is the nominal (rated) output current of the BOP (in Amps) and R_S is the resistance of the current sensing shunt resistor (in Ohms). So, e.g., for BOP 50-4 with a 0.01-Ohm shunt resistor the tolerance is $0.0001 \times 4 \times 0.01 = \pm 0.00004V$.
7. Turn off BOP.

4.3.7 FULL SCALE OUTPUT CURRENT CALIBRATION (R316/R314)

NOTE: Applies only to Models listed in Table 4-1, Note (1).

1. Turn BOP off and disconnect it from source power. Then remove the BOP cover.
Full Rack models: 9 screws on each side, 1 screw at front, 1 screw on top
3/4 Rack models: 5 screws on each side. 1 screw on top
2. Without a load connected to the BOP output, connect a precision 4-terminal current sensing shunt resistor (see Table 4-2) across the OUTPUT and COMMON at either the front (16 and 18, Figure 2-1) or rear terminals (terminals 2 and 5), Figure 2-2).
3. Connect the DVM to the shunt's sensing terminals.
4. Connect $-10V \pm 0.1mV$ reference voltage across the CURRENT PROGRAMMING INPUT terminals (11, Figure 2-1) on the front panel.
5. Locate R316 (R314 for BOP 200-1) and turn on BOP.
6. Adjust R316 or R314 so that the DVM connected to the current sensing shunt indicates $(I_{O\text{nom}} \times R_S)V$ where $I_{O\text{nom}}$ is the nominal (rated) output current of the BOP (in Amps) and R_S is the resistance of the current sensing shunt resistor (in Ohms). Tolerance is $\pm 0.0001 \times I_{O\text{nom}}$ (in Amperes) $\times R_S$ (in Ohms). So, e.g., for BOP 50-4 with a 0.01-Ohm shunt resistor adjust R316 for $0.0001 \times 4 \times 0.01 = 0.04V \pm 0.00004V$.

4.3.8 ADJUSTMENT OF OPTOCOUPLER LINEARIZATION CONTROL R15A (MODEL BOP 200-1 ONLY)

1. Turn BOP off and disconnect it from source power. Then remove the BOP cover.
Full Rack models: 9 screws on each side, 1 screw at front, 1 screw on top.
2. Connect a resistive load to the output. Set load to produce the rated maximum output current.
3. Attach an oscilloscope probe to test point, located on A1 control board (see Figure 4-2). (Oscilloscope common should be connected to output common of the unit). Select W/Division or 2V/Division sensitivity on the oscilloscope.
4. Set BOP to Voltage Mode (MODE switch, 6, Figure 2-1 to VOLTAGE position) with VOLTAGE CONTROL switch (2, Figure 2-1) to OFF position.
5. Turn BOP on. Using the Voltage Programming Input terminals (24, Figure 2-1), program the unit using a triangular voltage source (Function Generator) producing a 20V p-p, 250 Hz triangular wave. Referring to Figure 4-3, observe the output Signal on the scope, and adjust R15A Linearization control (see Figure 4-1) until the non-linearity in the ramps of the triangular wave disappears.
6. Adjust $E_{O\text{-OFF ZERO}}$ (A1R136) for $0V \pm (0.01\% \text{ of } E_{O\text{nom}})$ as read on DVM. (E.g., for BOP 5-20D and BOP 5-30D $E_{O\text{nom}}$ is 5V and adjustment tolerance is $\pm 0.5mV$.)

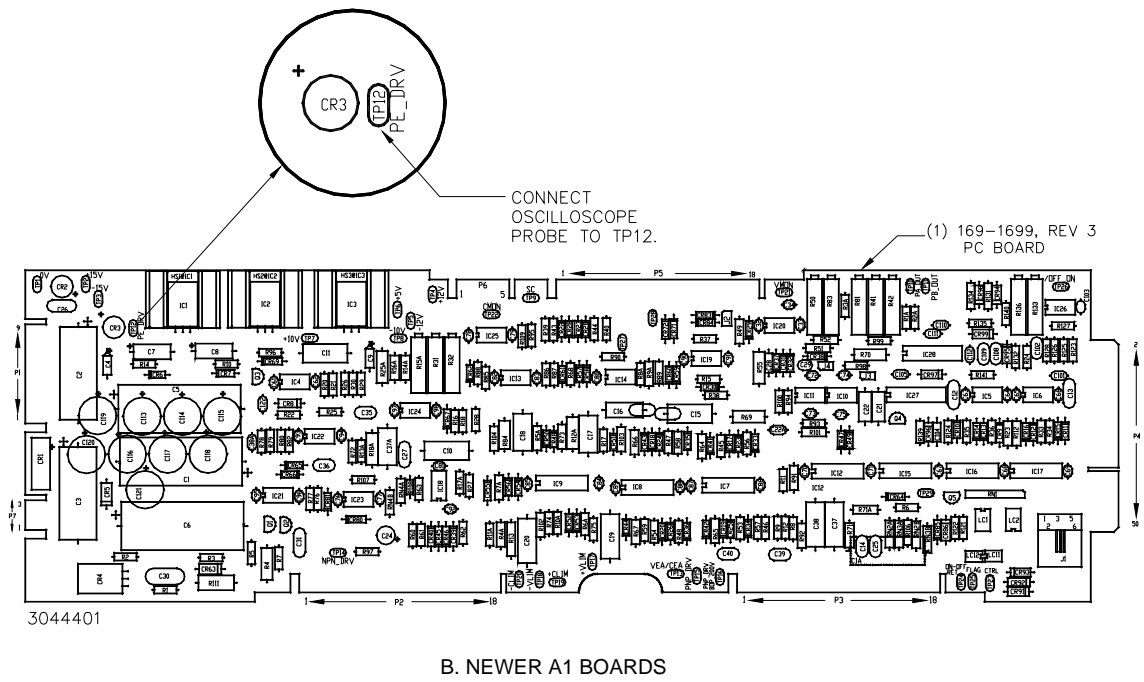
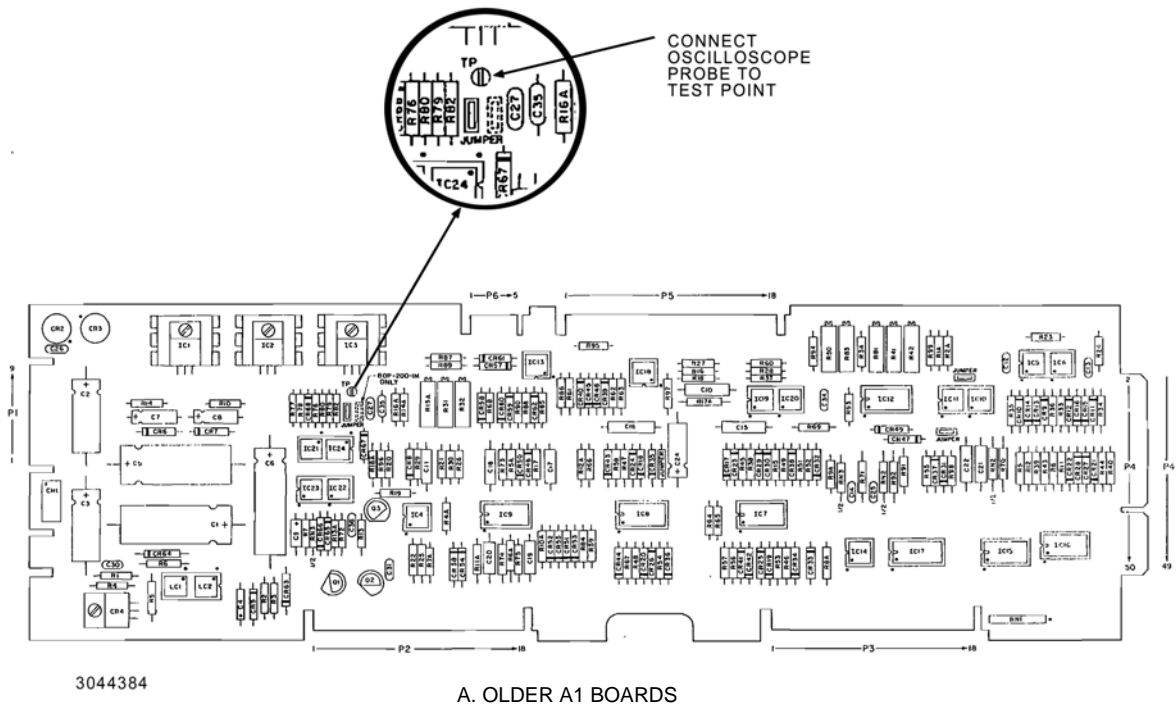
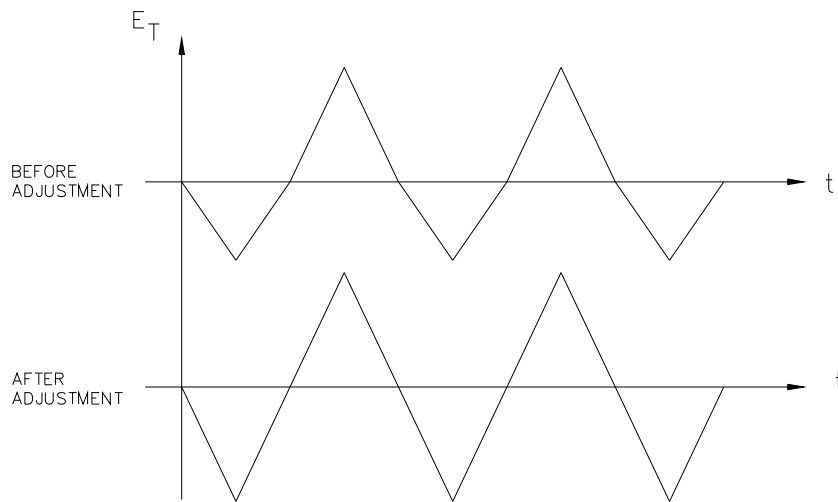

FIGURE 4-2. A1 BOARD, TEST POINT (TP) LOCATION



3044359

NOTE: THE TRIANGULAR WAVE DOES NOT HAVE TO SHOW ZERO VOLT DC AVERAGE.

FIGURE 4-3. OPTOCOUPLER LINEARIZATION (BOP 200-1 ONLY)

4.3.9 ADJUSTMENT OF I_O -OFF ZERO (A1R133) AND E_O -OFF ZERO (A1R136)

1. At rear panel, connect a wire jumper between terminals 21 and 23 of the Rear Programming connector to set the output to OFF (disabled).
2. Connect precision shunt resistor across the BOP OUTPUT and COMMON terminals. Connect DVM to the shunt's sensing terminals for output current measurements.
3. Set MODE switch to CURRENT and CURRENT CONTROL switch to OFF, then turn the BOP on.
4. Adjust I_O -OFF ZERO (A1R133) potentiometer (see Figure 4-1) for $0A \pm(0.01\% \text{ of } I_{O\text{nom}})$ as read on the DVM connected to the shunt. E.g., for BOP 5-20D $I_{O\text{nom}}$ is 20A and adjustment tolerance is $\pm 2\text{mA}$.
5. Turn off the BOP and remove the shunt resistor from the output. Connect the DVM to the output sensing terminals of the BOP (OUT S and COM S).
6. Set MODE switch to VOLTAGE and VOLTAGE CONTROL switch to OFF, then turn the BOP on.
7. Adjust E_O -OFF ZERO (A1R136) for $0V \pm(0.01\% \text{ of } E_{O\text{nom}})$ as read on DVM. E.g., for BOP 5-20 $E_{O\text{nom}}$ is 5V and adjustment tolerance is $\pm 0.5\text{mV}$.