

OPERATOR MANUAL

MAT 360W, 1/3-RACK SERIES POWER SUPPLY

MAT 6-32, MAT 15-20, MAT 25-14, MAT 36-10,
MAT 55-7, MAT 75-5, MAT 100-3.6, MAT 150-2.4

KEPCO INC.
An ISO 9001 Company.

CE	
MODEL MAT 360W POWER SUPPLY	
ORDER NO.	REV. NO.

IMPORTANT NOTES:

- 1) This manual is valid for the following Model and associated serial numbers:

MODEL	SERIAL NO.	REV. NO.
MAT 6-32		
MAT 15-20		
MAT 25-14		
MAT 36-10		
MAT 55-7		
MAT 75-5		
MAT 100-3.6		
MAT 150-2.4		

- 2) A Change Page may be included at the end of the manual. All applicable changes and revision number changes are documented with reference to the equipment serial numbers. Before using this Instruction Manual, check your equipment serial number to identify your model. If in doubt, contact your nearest Kepco Representative, or the Kepco Documentation Office in New York, (718) 461-7000, requesting the correct revision for your particular model and serial number.
- 3) The contents of this manual are protected by copyright. Reproduction of any part can be made only with the specific written permission of Kepco, Inc.

©2018, KEPCO, INC
P/N 243-1392



Conditions of Conformance

When this product is used in applications governed by the requirements of the EEC, the following restrictions and conditions apply:

1. For European applications, requiring compliance to the Low Voltage Directive, 73/23/EEC, this power supply is considered a component product, designed for "built in" applications. Because it is incomplete in construction, the end product enclosure must provide for compliance to any remaining electrical safety requirements and act as a fire enclosure. (EN61010-1:2001, Cl. 6, Cl. 7, Cl.8, and Cl. 9)
2. This power supply is designed for stationary installation within an RA 50 or RA 51 rack adapter. Mains power is supplied via a detachable power supply cord or via direct wiring to the source power terminal block.
3. This power supply is considered a Class 1 (earthed) product. It is intended for use as part of equipment meant for test, measurement and laboratory use, and is designed to operate from single phase, three wire power systems. This equipment must be installed within a suitably wired equipment rack, utilizing a three wire (grounded) mains connection. See wiring section of this manual for complete electrical wiring instructions. (EN61010-1:2001, Cl.6.10.1)
4. This power supply has secondary output circuits that are considered hazardous, and which exceed 240 VA at a potential of 2V or more.
5. The output wiring terminals of this power supply have not been evaluated for field wiring and, therefore, must be properly configured by the end product manufacturer prior to use.
6. This power supply employs a supplementary circuit protector in the form of a circuit breaker mounted on the front panel. This circuit breaker protects the power supply itself from damage in the event of a fault condition. For complete circuit protection of the end product, as well as the building wiring, it is required that a primary circuit protection device be fitted to the branch circuit wiring. (EN61010-1:2001, Cl. 9.5)
7. Hazardous voltages are present within this power supply during normal operation. All operator adjustments to the product are made via externally accessible switches, controls and signal lines as specified within the product operating instructions. There are no user or operator serviceable parts within the product enclosure. Refer all servicing to qualified and trained Kepco service technicians.

SAFETY INSTRUCTIONS

1. Installation, Operation and Service Precautions

This product is designed for use in accordance with EN 61010-1 and UL 3101 for Installation Category 2, Pollution Degree 2. Hazardous voltages are present within this product during normal operation. The product should never be operated with the cover removed unless equivalent protection of the operator from accidental contact with hazardous internal voltages is provided:



There are no operator serviceable parts or adjustments within the product enclosure. Refer all servicing to trained service technician.



Source power must be removed from the product prior to performing any servicing.



This product is factory-wired for the nominal a-c mains voltage indicated on the rating nameplate located adjacent to the source power connection on the product's rear panel. To reconfigure the product input for other nominal mains voltages as listed herein, the product must be modified by a trained service technician.

2. Grounding

This product is a Class 1 device which utilizes protective earthing to ensure operator safety.



The PROTECTIVE EARTHING CONDUCTOR TERMINAL must be properly connected prior to application of source power to the product (see instructions on installation herein) in order to ensure safety from electric shock.



PROTECTIVE EARTHING CONDUCTOR TERMINAL - This symbol indicates the point on the product to which the protective earthing conductor must be attached.



EARTH (GROUND) TERMINAL - This symbol is used to indicate a point which is connected to the PROTECTIVE EARTHING TERMINAL. The component installer/ assembler must ensure that this point is connected to the PROTECTIVE EARTH-ING TERMINAL.

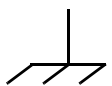

CHASSIS TERMINAL - This symbol indicates frame (chassis) connection, which is supplied as a point of convenience for performance purposes (see instructions on grounding herein). This is not to be confused with the protective earthing point, and may not be used in place of it.

3. Electric Shock Hazards

This product outputs hazardous voltage and energy levels as a function of normal operation. Operators must be trained in its use and exercise caution as well as common sense during use to prevent accidental shock.



This symbol appears adjacent to any external terminals at which hazardous voltage levels as high as 500V d-c may exist in the course of normal or single fault conditions.



This symbol appears adjacent to any external terminals at which hazardous voltage levels in excess of 500V d-c may exist in the course of normal or single fault conditions.

TABLE OF CONTENTS

SECTION	PAGE
SECTION 1 - INTRODUCTION	
1.1	Scope Of Manual..... 1-1
1.2	General Description..... 1-1
1.3	Specifications, Electrical..... 1-3
1.4	DC Output Ratings For 1/3, 2/3 And Full Rack Modules..... 1-4
1.5	Miscellaneous Features 1-7
1.6	Accessories 1-7
1.7	Safety 1-8
SECTION 2 - INSTALLATION	
2.1	Unpacking And Inspection..... 2-1
2.2	Transport instructions..... 2-1
2.3	Terminations..... 2-2
2.4	AC Input Requirement..... 2-5
2.5	Cooling 2-6
2.6	Installation 2-6
2.7	Grounding..... 2-7
2.7.1	Safety Grounding..... 2-7
2.7.2	DC (Output) Grounding..... 2-8
2.7.3	Power Module To Load Interface..... 2-8
2.7.4	Load Connection, Local Error Sensing..... 2-9
2.7.5	Load Connection With Remote Error Sensing..... 2-10
2.8	Operating Configuration 2-10
2.9	Preliminary Check-out 2-11
2.9.1	Example 1: Full Scale Voltage Check..... 2-12
2.9.2	Example 2: Full Scale Current Check..... 2-13
2.9.3	Example 3: To Reset the Power Module..... 2-14
SECTION 3 - OPERATION	
3.1	General..... 3-1
3.2	Series Connection Of MAT Power Modules..... 3-1
3.3	Power Module Controller/MAT Time Delays (To Obtain A Valid Status):..... 3-1
3.4	Power Loss Circuit 3-2
3.5	Introduction To Controlling The MAT Power Module Output..... 3-2
3.5.1	MAT/Power Module Controller System..... 3-4
3.5.2	MAT/TMA Pc-27 System 3-5
3.6	Remote Programming 3-6
3.6.1	General 3-6
3.6.2	SCPI Programming..... 3-6
3.6.2.1	SCPI Program Example..... 3-7
3.6.3	CIIL Programming..... 3-8
3.6.3.1	Examples Using CIIL To Program The MAT Power Module..... 3-8
3.6.3.1.1	Example 1: Program Positive Voltage With Current Limit..... 3-8
3.6.3.1.2	Example 2 : Program Negative Voltage With Current Limit 3-10
3.6.3.1.3	Example 3: Program Current And Voltage Limit 3-11
3.7	MAT Calibration Procedure 3-12
3.7.1	E/I Zero Calibration..... 3-13
3.7.2	E/I Full Scale Calibration 3-14
APPENDIX A - CIIL COMMAND DEFINITIONS	

LIST OF FIGURES

FIGURE	TITLE	PAGE
1-1	Remotely Controlled Power Supply Configurations Using Kepco Products	1-2
1-2	MAT Power Module Mechanical Outline Drawing	1-6
1-3	The TMA 4882-27 Controller And MAT Power Modules	1-8
2-1	Front View Of The 1/3 Rack MAT Power Supply	2-3
2-2	Rear View Of The 1/3 Rack Power Module.....	2-4
2-3	MAT Module Barrier Strip With Jumpers For 115 Or 230 Va-c	2-6
2-4	Variation Of Output Impedance With Frequency For A Voltage Source And A Current Source	2-8
2-5	Load Connections, Local Sensing.....	2-9
2-6	Load Connections, Remote Sensing.....	2-10
3-1	Two MAT 1/3 RACK Power Modules Connected In Series Via Their Output Connector	3-2
3-2	MAT Power Module Control Section, Top Cover Removed	3-3
3-3	Tree Diagram of SCPI Commands Used with MAT Power Supplies	3-6
3-4	Typical Example Of MAT Power Supply Program Using SCPI Commands.....	3-7
3-5	MAT Power Module Calibration Requires Adjustment Of The Above Controls.....	3-16
A-1	FNC — Function Command	A-1
A-2	INX — Initiate Op Code Command	A-2
A-3	FTH — Fetch Command	A-2
A-4	SET Command.....	A-3
A-5	OPN, CLS — Open, Close Relay Commands	A-4
A-6	RST — Reset Command.....	A-4
A-7	CNF, IST — Confidence Test, Internal Self Test Commands	A-4
A-8	STA — Status Command	A-5

LIST OF TABLES

TABLE	TITLE	PAGE
1-1	MAT Power Module Features And Specifications	1-3
1-2	MAT Power Modules Power Output Ratings	1-4
1-3	Safety Symbols	1-8
2-1	Hardware Required for Reshipment in Transport Cover	2-1
2-2	Internal Controls Accessible Through Top Cover	2-2
2-3	Front Control MAT Power Module	2-3
2-4	Rear Terminations MAT Power Module	2-4
2-5	Ac Input/Control Bus Connector Pin Designations	2-4
2-6	DC Output Connector Pin Designations	2-5
2-7	Internal Jumper Configuration	2-11
3-1	Device Address Selection For The MAT power Module	3-4
A-1	CIIL Subsystem Command/query Index	A-1
A-2	CIIL Error Messages	A-5

SECTION 1 - INTRODUCTION

1.1 SCOPE OF MANUAL

This manual contains instructions for the installation, operation, and calibration of the 1/3 Rack size 360W MAT series of voltage and current stabilized DC Power Modules manufactured by Kepco, Inc. Flushing, New York, U.S.A.

1.2 GENERAL DESCRIPTION

The Kepco MAT Power Module with overvoltage, overcurrent, overtemperature, polarity reversal, and power loss protection is a digitally controlled precision stabilized Power Module that delivers either stabilized voltage or current. A single front panel meter with a selector switch constantly monitors the output voltage or the output current. The prevailing operating mode is indicated by LED mode indicators on the front panel. Operating mode crossover is dependent on commands from a Host Computer. The Power Module has a linear and fully dissipative NPN pass transistor driven by high gain integrated circuit amplifiers. The output of the Power Module is fully programmable.

The Power Module features full range output control by means of a compatible Kepco Power Module Controller. Control of the MAT Power Module is via the IEEE 1118 2-wire serial bus operating at 375KHz; as many as 27 separate modules of either the MAT, MST, MBT or BOP Series design can be addressed via the bus (see Figure 1-1). Decoders for RS232, IEEE-488 and VXI are available in modular form and stand-alone types. As shown in Figure 1-1, the following controllers are available to control of MAT Power Modules directly from a computer.

- a. Controller Model TMA PC-27 plugs into a half-track slot of a DOS-based PC and allows keyboard control of the MAT via the IEEE 1118 bus.
- b. Controller Model TMA 4882-27 is freestanding and allows host computers designed for RS232 or IEEE 488 bus communication to control the MAT via the IEEE 1118 bus.
- c. Controller Model TMA-VXI-27 plugs into a slot in a VXI chassis and allows VXI-based computers to control the MAT via the IEEE 1118 bus.
- d. Controller Model MST 488-27 plugs into a slot in a Model RA 55 Rack Adapter and allows host computers designed for RS232 or IEEE 488 bus communication to control the MAT via the IEEE 1118 bus.
- e. The MAT Power Module can also be directly controlled via the keypad of the MBT Series ("G" Option) Power Supply via the IEEE 1118 bus.

An important feature of the MAT Series Power Module is the overvoltage and overcurrent protection circuits. This protection is provided by two autotracking amplifiers that have an overvoltage and overcurrent tracking range of $10\% \pm 3\%$ above the programmed Power Module output voltage or current.

The MAT series Power Modules are built in 1/3 Rack, 2/3 Rack and Full Rack mechanical sizes according to their approximate output power rating (see Mechanical Outline Drawing of the Power Module Chassis, Figure 1-2).

Power transistors and drivers on all Power Module designs are mounted on highly efficient patented heat sink assemblies that are cooled by fans.

MAT 1/3 and 2/3 Rack size modules are designed to operate in either one of two housings called RA 50 and RA 51. RA 50 is 5-1/4" x 19" x 25" and accepts up to three 1/3 Rack Power Modules. RA 51 is similarly sized, but configured for one 1/3 Rack Module and one 2/3 Rack Module. Full Rack MAT Power Modules mount directly into a standard 19 inch Equipment Rack.

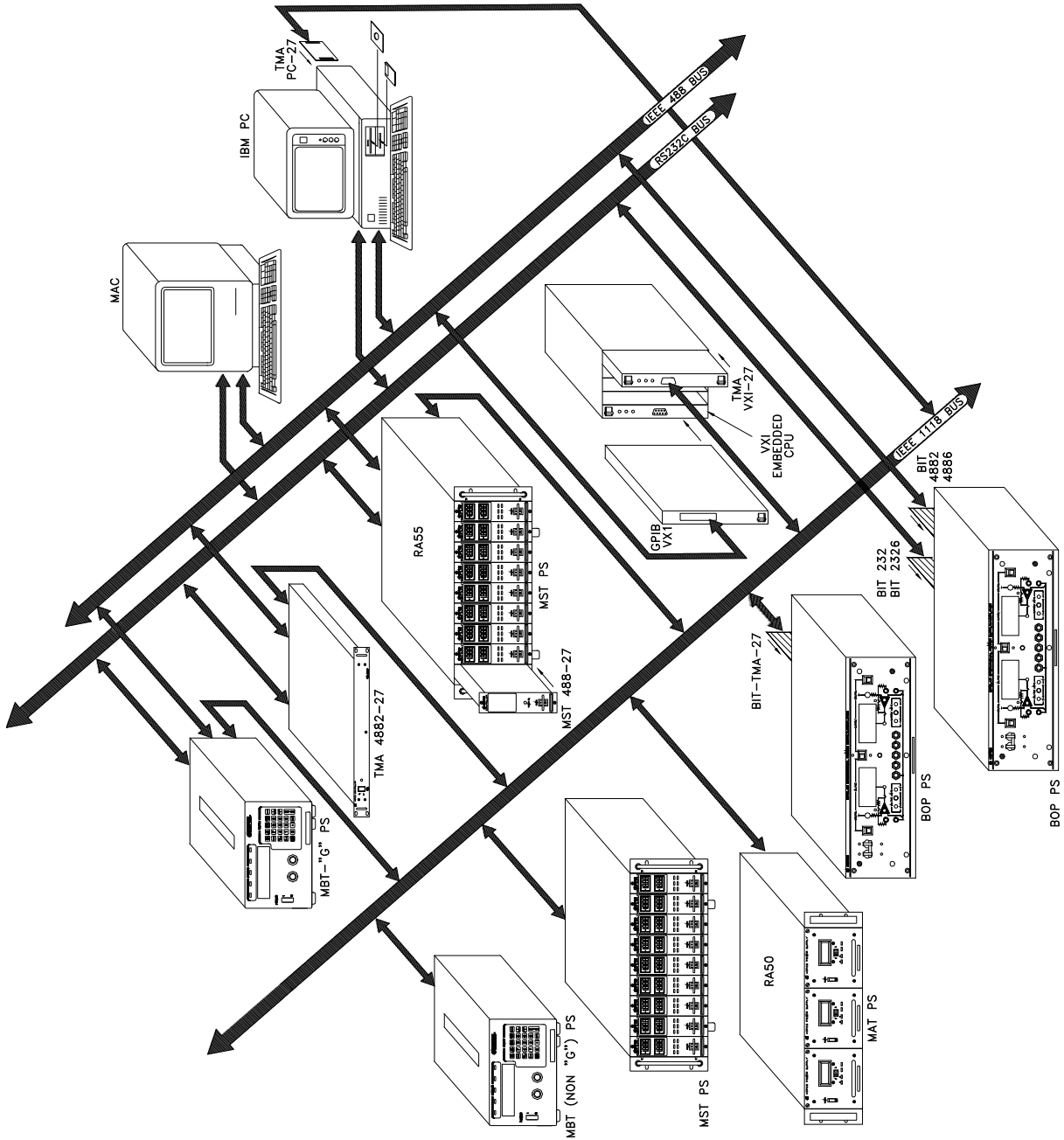

3040800

FIGURE 1-1. REMOTELY CONTROLLED POWER SUPPLY CONFIGURATIONS USING KEPSCO PRODUCTS

1.3 SPECIFICATIONS, ELECTRICAL

a) MAT Power Module Features And Specification

TABLE 1-1. MAT POWER MODULE FEATURES AND SPECIFICATIONS

PARAMETER	CONDITION	MAT POWER MODULE		
		1/3 RACK	2/3 RACK	FULL RACK
Input Voltage Range	USER SELECTABLE	105-125 VAC 210-250 VAC		
Input Current Max	115 VAC	7.0A	14.0A	21.0A
	230 VAC	3.5A	7.0A	10.5A
Input Frequency	RANGE	47-63 Hz		
Voltage/Current Adjustment Range	RANGES	0 to 100% of rating, by preprogrammed setting, within inherent resolution limits		
Programming Resolution	Voltage	0.024% Eo max (12 bits)		
	Current	0.024% Io max (12 bits)		
Programming Accuracy	Voltage	0.024% Eo max		
	Current	0.1% Io max		
Data Read Back Accuracy via Digital Bus	Voltage	0.1% Eo max		
	Current	0.12% Io max		
Source Effect	Voltage	0.001% Eo max		
	Current	0.005% Io max		
Load Effect	Voltage	0.002% Eo max		
	Current	0.024% Io max or 4 mA (whichever is greater)		
Time 8 Hour Drift	Voltage	0.01% Eo max		
	Current	0.02% Io max		
Temperature Coefficient/°C	Voltage	0.01% Eo max		
	Current	0.02% Io max		
Ripple & Noise	Voltage	rms: 0.001% Eo max or 0.3 mV (whichever is greater) p-p: 0.01% Eo max or 3 mV (whichever is greater)		
	Current	rms: 0.03% Io max p-p: 0.3% Io max		
Transient Recovery	Voltage	150 µsec to recover within 0.1% Eo max for 10% to 100% step in rated load current		
Temperature	Operating	0 to 50 °C		
	Storage	-20 to +70 °C		
Cooling		Built-in fan, air exhaust to rear		
Remote Sensing	Range	0.5 volts per lead (Provision for 4-terminal connection to load)		
DC Output Isolation	Voltage	500 Vdc		
Leakage Current	Output to chassis	5µA rms or 50µA p-p @ 115V a-c		
Series/Parallel Operation		Consult Kepco application engineering		
Output Display	3-1/2 digit LCD Panel Meter	Switch selectable voltage/current		
Indicators	4 LEDs	Voltage and Current Mode, Output Enabled, Polarity Reversed		
Output Enable/Disable		Built in power and sensing relays controlled through IEEE 1118 bus		
Polarity Reversal		Built in power and sensing relays controlled through IEEE 1118 bus		

TABLE 1-1. MAT POWER MODULE FEATURES AND SPECIFICATIONS (CONTINUED)

PARAMETER	CONDITION	MAT POWER MODULE		
		1/3 RACK	2/3 RACK	FULL RACK
Protection	Overtoltage	Tracks program voltage, Crowbars output and turns off input		
	Overcurrent	Tracks program current, Crowbars output and turns off input		
	Overtemperature	Monitors heat sink temperature, Crowbars output and turns off input		
	Polarity Reversal	Built in diodes protect unipolar supply output		
	Power Loss	Detects loss of ac input power, disables output		
Source Connections		3-wire power entry, via user-configurable mating connector (supplied) and proper gage wires (not supplied)		
Load Connections		5-wire connection, via user-configurable mating connector (supplied) and proper gage wires (not supplied) DC Power Output: 2 wires Output Sense Terminals: 2 wires Ground: 1 wire		
Remote Control Signal Connections		Two 2-wire connections via user-configurable mating connector supplied and 22 AWG wire (not supplied). Connectors in parallel for daisy chaining multiple power supplies (full rack only).		
Dimensions		See Figure 1-2.		
Weight	LBS	33	60	75
Mounting	Front	Three 1/3 rack modules plug into RA 50. One 1/3 and one 2/3 rack modules plug into RA 51	One 1/3 and one 2/3 rack modules plug into RA 51	Full Rack mounts directly into 19 inch Rack
Filler Panels	For either RA 50 or RA 51	RFP 50-1: 1/3 Panel RFP 50-2: 2/3 Panel.		

1.4 DC OUTPUT RATINGS FOR 1/3, 2/3 AND FULL RACK MODULES

- a. MAT Power Module DC Output Ratings 1/3, 2/3, and Full Rack Size - see Table 1-2
- b. Output range:
 - 1) Voltage mode: 0-100% of rated voltage
 - 2) Current mode: 0-100% of rated current

TABLE 1-2. MAT POWER MODULES POWER OUTPUT RATINGS

360W MODULES-1/3 RACK SIZE-DC OUTPUT RATINGS			
MODEL	VOLTS	AMPS	POWER
MAT 6-32	0-6	0-32	192
MAT 15-20	0-15	0-20	300
MAT25-14	0-25	0-14	350
MAT 36-10	0-36	0-10	360
MAT 55-7	0-55	0-7	385
MAT 75-5	0-75	0-5	375
MAT 100-3.6	0-100	0-3.6	360
MAT 150-2.4	0-150	0-2.4	360

TABLE 1-2. MAT POWER MODULES POWER OUTPUT RATINGS

360W MODULES-1/3 RACK SIZE-DC OUTPUT RATINGS			
720W MODULES-2/3 RACK-DC OUTPUT RATINGS			
MODEL	VOLTS	AMPS	POWER
MAT 6-64	0-6	0-64	384
MAT 15-40	0-15	0-40	600
MAT25-28	0-25	0-28	700
MAT 36-20	0-36	0-20	720
MAT 55-14	0-55	0-14	770
MAT 75-10	0-75	0-10	750
MAT 100-7.2	0-100	0-7.2	720
MAT 150-4.8	0-150	0-150	720
1080W MODULES-FULL RACK-DC OUTPUT RATINGS			
MODEL	VOLTS	AMPS	POWER
MAT 6-100	0-6	0-100	600
MAT 15-60	0-15	0-60	900
MAT 25-42	0-25	0-42	1050
MAT 36-30	0-36	0-30	1080
MAT 55-20	0-55	0-20	1100
MAT 75-15	0-75	0-15	1125
MAT 100-10	0-100	0-10	1000
MAT 150-7	0-150	0-7	1050

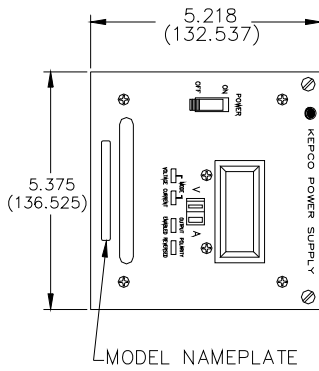
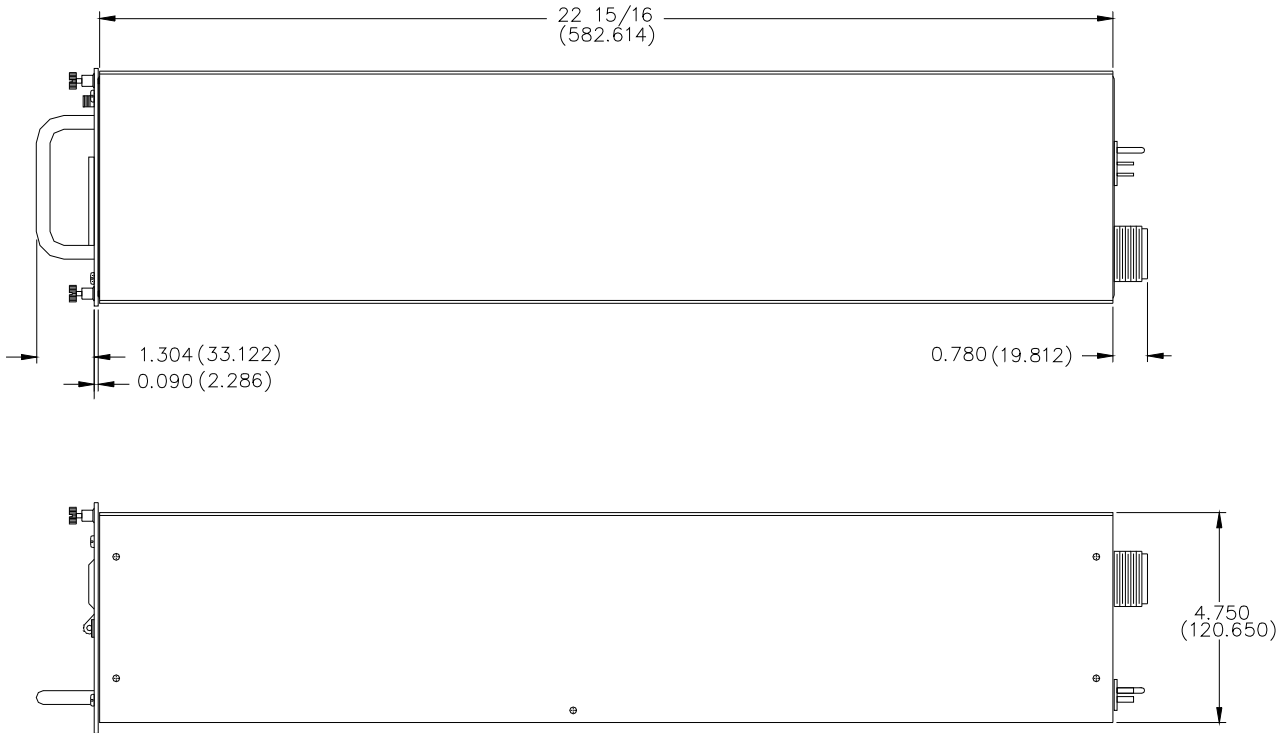

NOTES:

1. MATERIAL
 - A) CHASSIS: 0.06 THICK COLD ROLLED STEEL
 - B) COVER: THE COVER IS USED ONLY FOR TRANSPORT PURPOSES, IT IS HELD IN PLACE WITH EIGHT SCREWS
 - C) FRONT PANEL: 0.09 THICK ALUMINUM (6061-T6)
2. FINISH
 - A) CHASSIS: CADMIUM PLATED 0.0005 WITH A CHROMATE WASH (IRIDESCENT YELLOW)
 - B) FRONT PANEL: KEPKO GRAY, HARTIN PAINT No.15-22493
3. DIMENSIONS IN PARENTHESIS ARE IN MILLIMETERS
4. TOLERANCES
 - A) BETWEEN MOUNTING HOLES: $\pm 1/64$ (± 0.4)
 - B) ALL OTHER DIMENSIONS $\pm 1/32$ (± 0.8) EXCEPT AS NOTED

3010033

FIGURE 1-2. MAT POWER MODULE MECHANICAL OUTLINE DRAWING

1.5 MISCELLANEOUS FEATURES

- a. Mode flag: A pair of panel LED indicators indicate whether the Power Module is in voltage mode or in current mode.
- b. Remote error sensing: Separate voltage-sensing terminals permit 4-wire connections to a load to compensate for static load effects (up to 0.5V per lead). An additional 1 volt output voltage, beyond the nominal voltage rating of each MAT Power Module, is provided for this purpose.
- c. Storage temperature range: -20 to +85° C.
- d. Cooling: The fans are high efficiency, single bearing fans with special low-noise non-metallic blades

1.6 ACCESSORIES

NOTE: All Kepco rack adapters fit standard EIA rack dimensions. They are drilled for chassis slides (see the RA 50 or RA 51 manual).

- a. Kepco Rack Adapter Model RA-50 is for three 1/3 Rack Size Power Modules. Filler panels are available to cover empty slots, if the adapter is not used to its full capacity.
- b. Kepco Rack Adapter Model RA-51 is for one 1/3 Rack Size, and one 2/3 Rack Size Power Modules. Filler panels to cover empty slots are available if the adapter is not used to its full capacity. The Full Rack MAT Power Modules fit directly into a standard 19 inch Rack.
- c. One 2 meter long shielded twisted pair cable with two mating connectors, one at each end (Kepco P/N 118-0699) is supplied with each Rack Adapter (RA 50 or RA 51) and with each Full Rack MAT Power Module. The Power Module Controller (see PAR. 1.2) and up to 27 MAT Power Modules can be connected in a daisy chain configuration as shown in FIG. 1-3. The last (in the daisy chain) Power Module Control Bus Outlet must be terminated with a Terminating Connector Assembly (Kepco P/N 195-0075) that is supplied with the Power Module Controller.

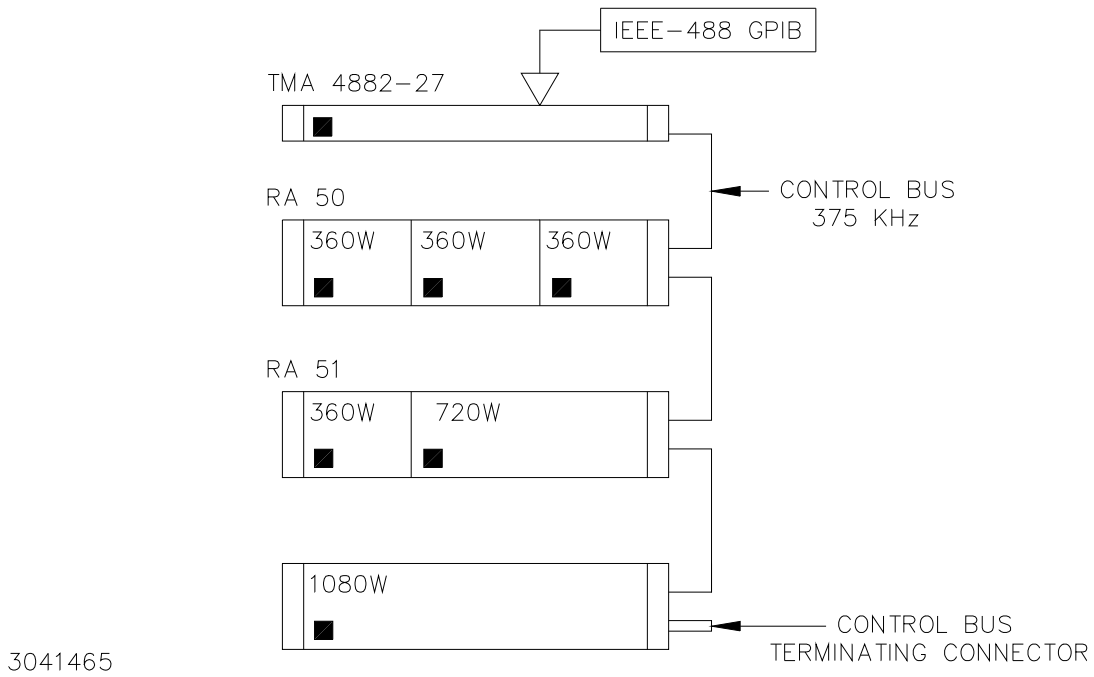



FIGURE 1-3. THE TMA 4882-27 CONTROLLER AND MAT POWER MODULES

1.7 SAFETY

There are no operator serviceable parts inside the case. Service must be referred to authorized personnel. Using the power supply in a manner not specified by Kepco, Inc. may impair the protection provided by the power supply. Observe all safety precautions noted throughout this manual. Table 1-3 lists symbols used on the power supply or in this manual where applicable.

TABLE 1-3. SAFETY SYMBOLS

SYMBOL	Meaning
	CAUTION: RISK OF ELECTRIC SHOCK.
	CAUTION: REFER TO REFERENCED PROCEDURE.
WARNING	INDICATES THE POSSIBILITY OF BODILY INJURY OR DEATH.
CAUTION	INDICATES THE POSSIBILITY OF EQUIPMENT DAMAGE.

SECTION 2 - INSTALLATION

2.1 UNPACKING AND INSPECTION

This instrument has been thoroughly inspected and tested prior to packing and is ready for operation. After careful unpacking, inspect for shipping damage before attempting to operate. Perform the preliminary operational check as outlined in PAR 2.9 If any indication of damage is found, file an immediate claim with the responsible transport service.

The MAT 1/3 rack module may be received in either of two ways; with a special transport cover or in a RA 50 or RA 51 housing. Below are the procedures necessary to remove the MAT power module from its housing or transport cover

- a. For the MAT 1/3 rack power module in a transport cover, there are ten screws (self tapping countersunk Flat Head Phillips size no. 6-32 x 3/8, Kepco P/N 101-0344) located at each side of the transport cover. These screws must be removed and saved with the cover for later transport use.

NOTE: If the Power Modules are shipped in the RA 50 or RA 51 Rack Adapter, the power modules must be removed before installing the rack adapter in a rack.

- b. To remove the 1/3 rack power module from the RA 50/RA 51 housing, loosen the two slotted captive thumb screws on the front panel, then remove and save the six Flat Head Phillips screws from the base of the housing. Slide the power module out of the housing and set the Control Bus Address (see PAR. 3.5). Slide the power module back into the housing and fasten the two slotted captive thumb screws It is not advisable to replace the six Flat Head Phillips screws in the base of the housing unless the unit is going to be transported.

2.2 TRANSPORT INSTRUCTIONS

CAUTION

THE MAT POWER MODULE SHOULD BE SHIPPED ONLY IN THE RACK ADAPTER OR IN A TRANSPORT COVER. FAILURE TO PROPERLY SECURE THE MAT POWER MODULE BEFORE SHIPPING WILL RESULT IN SEVERE DAMAGE TO THE EQUIPMENT AND VOID THE WARRANTY.

The MAT Power Module is a relatively heavy piece of equipment, particularly due to the main Power Transformer, chassis frame and electrolytic capacitors. This means that the unit when shipped, must be properly fastened in a transport cover, rack adapter or by other means; otherwise the Power Module may buckle at the center of gravity of the chassis due of its weight.

To transport the MAT Power Module in the transport cover (supplied with the unit) secure the power module with 6-32 steel round head phillips screws (see Table 2-1).

TABLE 2-1. HARDWARE REQUIRED FOR RESHIPMENT IN TRANSPORT COVER

FOR THESE MAT POWER MODULES	USE THIS TRANSPORT COVER KEPCO P/N	USE THESE SCREWS	
		6-32 x 3/8 (KEPCO P/N 101-0344)	6-32 x 3/4 (KEPCO P/N 101-0349)
1/3 RACK	129-0231	QTY 10	N/A
2/3 RACK	129-0232	QTY 14	QTY 2

To transport the MAT Power Module in the Rack Adapter RA 50/ RA 51, secure each Power Module with Flat Head Phillips screws (self tapping countersunk Flat Head Phillips size no. 8-5/8, Kepco P/N 101-0421), six for 1/3 rack models and eight for 2/3 rack models.

If a transport cover is not available, the MAT power module may be mounted on a 3/4 inch thick (or greater) piece of wood by using 8-18 thread-forming screws with a type B style point. A screw should be used to secure the wood to each of the mounting grommets in the bottom of the chassis.

2.3 TERMINATIONS

1. Internal Calibration Controls: Refer to Table 2-2 and Figure 3-2.
2. Front Panel: Refer to Table 2-3 and Figure 2-1.
3. Rear Panel: Refer to Table 2-4 and Figure 2-2.

TABLE 2-2. INTERNAL CONTROLS ACCESSIBLE THROUGH TOP COVER

REFERENCE DESIGNATION	CONTROL	PURPOSE
A1R28	$I_{O\ ZERO}$ (NOTE 1)	Used to adjust output current of power supply to initial value. CONDITIONS: current mode, shunt at the output.
A1R20	$E_{O\ ZERO}$ (NOTE 1)	Used to adjust output voltage of power supply to zero. CONDITIONS: voltage mode, no load.
A1R15	$I_{\ CURRENT\ SENSING\ ZERO}$ (NOTE 1)	Used to adjust current monitor amplifier to zero. CONDITIONS: voltage mode, no load.
A1R16	$I_{\ FULL\ SCALE\ CURRENT\ ADJUST}$ (NOTE 1)	Used to calibrate the full scale value of the output current. CONDITIONS: current mode, shunt at the output.
A1R11	$V_{\ REF}$ (NOTE 1)	Used to calibrate full scale voltage. CONDITIONS: voltage mode, no load.
A1R12	$I_{\ REF}$ (NOTE 1)	Used to adjust internal full scale current. CONDITIONS: current mode, shunt at the output.
A3S1	Node Address	Used to select Node address (node number or channel number) of the MAT Power Supply from 1 - 31
A1TP1	Test Points	Provides four test points used for testing/calibration 1 - CURRENT REFERENCE 2 - CURRENT MONITOR 3 - VOLTAGE REFERENCE 4 - COMMON
NOTES: 1. These adjustments must be done in accordance with the calibration procedure (see PAR. 3.7).		

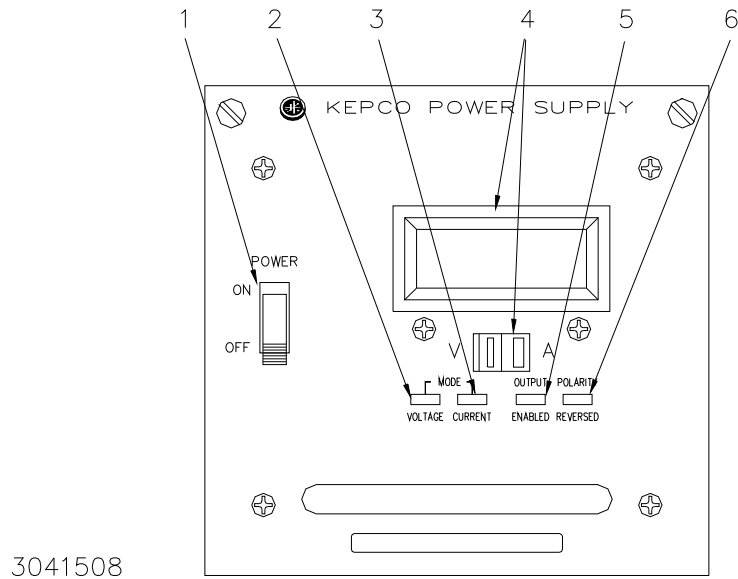

3041508

FIGURE 2-1. FRONT VIEW OF THE 1/3 RACK MAT POWER SUPPLY

TABLE 2-3. FRONT CONTROL MAT POWER MODULE

ITEM NO. (See Fig. 2-1)	CONTROL	FUNCTION
1	AC POWER Switch/circuit Breaker	Serves as an a-c power switch and turns the ac power line off on overvoltage, overcurrent, over-temperature or power loss. CAUTION: DO NOT repeatedly toggle the Switch/circuit Breaker as this may cause unit to fault. Set Power ON/OFF Switch/circuit Breaker on front panel to ON. If actuator does not lock when released, wait a few seconds before trying again. The circuit breaker is "trip-free" design; if over-load exists or the protection is activated, contacts cannot be held closed by actuator.
2	VOLTAGE MODE indicator, Green LED	Energized in VOLTAGE MODE.
3	CURRENT MODE indicator, Yellow LED	Energized in CURRENT MODE.
4	VOLTAGE/CURRENT Meter with Selection Switch, Green LED/ Yellow LED	Energizes to read output voltage. Energizes to read output current.
5	OUTPUT ENABLED indicator, green LED	Energized when relay closes and voltage is present at the power module output terminals.
6	POLARITY Reversed indicator, green LED	Energized when relay closes and polarity at power module output terminals is reversed.

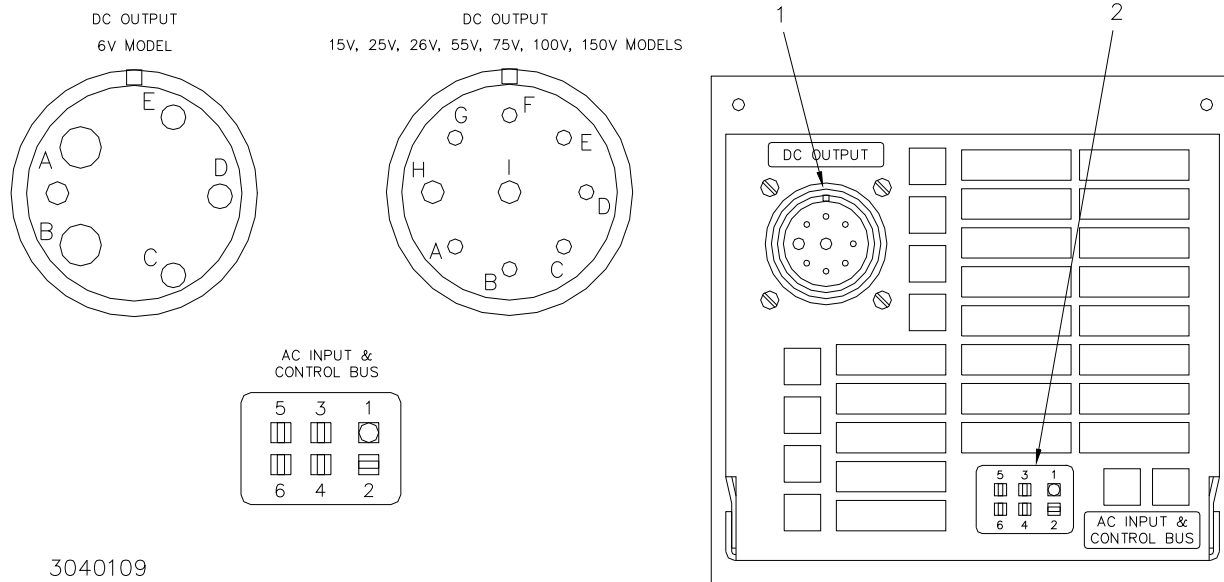

3040109

FIGURE 2-2. REAR VIEW OF THE 1/3 RACK POWER MODULE

TABLE 2-4. REAR TERMINATIONS MAT POWER MODULE

ITEM NO. (See Fig. 2-2)	REAR TERMINATION	FUNCTION
1	DC OUTPUT CONNECTOR	Connects the MAT power module output lines, sensing lines and ground line to the load (See Table 2-6 for pin designations.) Connector for 6V Model is Type MS3102A20-14S (mating connector is MS3106A20-14P, KEPCO P/N 142-0312, supplied). For all other models connector is Type MS3102A16-10P, (mating connector is MS3108A16--10S, KEPCO P/N 143-0331, supplied).
2	AC INPUT POWER/CONTROL BUS CONNECTOR	Connects MAT power module to a-c input power source and Bitbus controller via RA 50 or RA 51 rack adapter. Five pins are used for ac input, two for control bus connections (see Table 2-5). The power module controller and up to 27 MAT power modules can be connected (daisy chained) to the control bus (see PAR. 1.2).

TABLE 2-5. AC INPUT/CONTROL BUS CONNECTOR PIN DESIGNATIONS

CONNECTOR PIN (See Figure 2-2)	FUNCTION
1	SAFETY GROUND
2	AC "H" (HOT)
3	AC "N" (NEUTRAL)
4	NOT USED
5	CONTROL BUS (IEEE 1118 BUS) LINE
6	CONTROL BUS (IEEE 1118 BUS) LINE

TABLE 2-6. DC OUTPUT CONNECTOR PIN DESIGNATIONS

6V MODEL CONNECTOR PIN (See Figure 2-2)	15V, 25V, 36V, 55V, 75V, 100V, 150V MODELS CONNECTOR PIN (See Figure 2-2)	FUNCTION
A	H	CONNECTED TO OUTPUT TERMINAL 1
B	I	CONNECTED TO OUTPUT TERMINAL 2
E	A	CONNECTED TO SENSE TERMINAL 1
C	E	CONNECTED TO SENSE TERMINAL 2
D	D	CONNECTED TO SAFETY GROUND

2.4 AC INPUT REQUIREMENT

These Power Modules operate on a single phase, 115 Va-c nominal line. The Power Module can also be connected to 230 Va-c by the following procedure:

1. Disconnect the AC Input power from the RA 50 or RA 51 rack adapter
Turn OFF the circuit breaker on the module (if operating).
2. Remove the MAT Power Module from the RA 50 or RA 51 Rack Adapter by loosening two slotted captive screws at the top of the MAT front panel, then locate the barrier terminal block mounted on the chassis.

NOTE: Do not move the wires connected to the barrier strip, they are properly placed for both 115 Va-c and 230 Va-c operation.

3. Figure 2-3A shows the barrier terminal block set to 115 Va-c operation. Remove the jumpers on the barrier strip connecting terminals 2 to 3, and terminals 4 to 5.
4. Place a jumper between terminals 3 and 4. For 230 Va-c the barrier strip appears as in Figure 2-3B.
5. Verify that the source voltage on the Rack Adapter matches that of the Power Module.
6. Return the Module to the Rack Adapter

NOTE: To return to 115 Va-c operation reverse the procedure. Remove the jumper in step 4 and replace the jumpers in step 3.

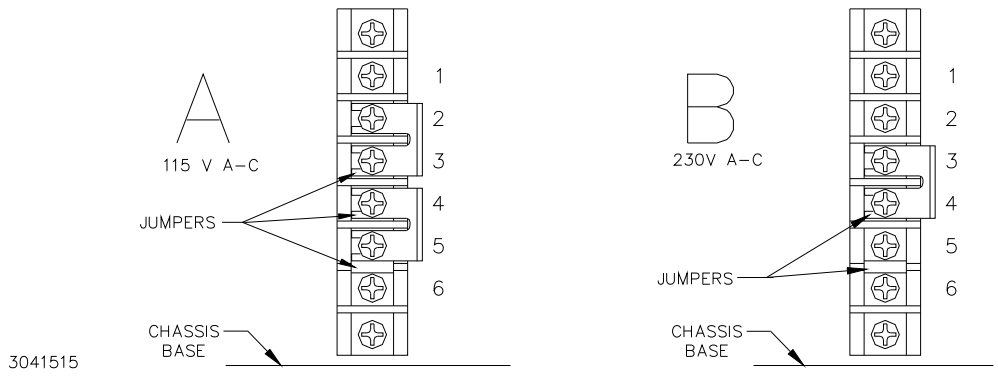

FIGURE 2-3. MAT MODULE BARRIER STRIP WITH JUMPERS FOR 115 OR 230 VA-C

2.5 COOLING

The power transistors and rectifiers in the MAT Power Module are maintained within their operating temperature range by means of special heat sink assemblies, cooled by an internal fan. **SIDE PANEL OPENINGS AND THE TOP OF THE CASE MUST BE KEPT CLEAR FROM OBSTRUCTIONS TO ENSURE PROPER AIR CIRCULATION.** If the MAT Power Module is rack mounted, or installed in confined spaces, care must be taken that the ambient temperature (the temperature immediately surrounding the Power Module) does not rise above the limit specified in Table 1-1.

2.6 INSTALLATION

If the unit is to be rack mounted install the RA 50 or RA 51 Rack Adapter in the rack per Rack Adapter instruction manual. Install the MAT 1/3 Rack Power Module in the Rack Adapter housing and secure with two front panel slotted screws. Refer to Rack Adapter manual for electrical connections of the rack adapter.

The following steps are recommended for inserting the Power Module into the Rack Adapter.

- Tilt the front of the Power Module slightly lower than the rear, set the two rear-most grommets of the Module on the front lip of the Rack Adapter opening.
- Lift the front of the Module until the bottom is approximately parallel to the bottom of the Rack Adapter and gently begin sliding in the Module, maintaining support with both hands as needed to prevent the bottom of the Module from scraping the lip of the Rack Adapter.
- Once the Module has been inserted approximately 1 inch, lift the handle upward, raising the front of the Power Module some 20° up relative to the back bottom edge of the unit (about an inch over the bottom front lip of the Rack Adapter). Allow the Module to slide against the bottom inside guides of the Rack Adapter. As this step is being done **MAKE SURE** that the top of the Power Module, in particular the white connector on top of the power module, clears the top edge of the Rack Adapter.
- Continue to lift the unit by the front handle while inserting the Module, until the front-most pair of grommets clear the front lip of the Rack Adapter, then allow the Module weight to be fully supported by the grommets on the bottom of the Module.

- Proceed further to slide the Module in by lifting the handle upward. When the Module is half way inserted (at the beginning of the transformer) remove the hand from the bottom of the unit
- At this point of the insertion process ensure that the Bit Bus twisted pair of white wires on the right side of the Power Transformer (as viewed when looking down over the front panel towards the back of the unit) does not get caught by the right edge of the Rack Adapter
- As the Power Module is inserted inside the Rack Adapter completely, a slight resistance will be felt when the Module connectors engage the mating connectors of the Rack Adapter. Continue to apply steady but firmer pressure to overcome the insertion force of the various connectors.
- If the module cannot be inserted fully using this type of force, remove the Power Module and inspect the rear panel and Rack Adapter for obstruction or damage. If the damage cannot be isolated return both the Power Module and Rack Adapter to Kepco along with a complete description of the problems encountered.
- when installed in a Rack Adapter that is in a Rack, the Rack Adapter must be securely fastened to the Rack **before** the Power Module is installed to avoid structural damage to the Rack Adapter.
- when being installed into the Rack Adapter, must be supported not only at the front of the assembly at the handle (by one hand), but also at or near the center of gravity of the chassis, underneath the assembly near the Power Transformer (by the other hand).
- if already in a Rack Adapter which is to be installed in an Equipment Rack, must be handled in exactly the same way as when installing the Power Module itself into a Rack Adapter. Failure to observe this caution could result in misalignment of the Power Modules with the Rack Adapter.

MAT Power Modules may also be operated as a bench type instrument. Leave the RA 50 or RA 51 feet installed, then install the MAT 1/3 Rack Power Module in the RA 50 or RA 51 Rack Adapter housing and secure with two front panel slotted screws. The RA 50 Rack Adapter houses up three 1/3 Rack Power Modules. The Rack Adapter may be equipped with Front Filler panels. The RFP 50-1 may be used to close one channel in the RA 50 or RA 51 Rack Adapter. Filler Panel RFP 50-2 can be used to close two channels in the RA 50 or RA 51 Rack Adapter.

For installation into confined spaces care must be taken that the surrounding environment does not exceed the maximum specified ambient temperature of 50°C (see PAR. 2.5).

2.7 GROUNDING

2.7.1 SAFETY GROUNDING

- a. AC Safety Ground: The Power Module is connected to the AC safety ground via the AC INPUT/CONTROL BUS connector and the corresponding rack adapter connector.
- b. Isolation From Ground: The DC output is isolated from the ac source and from the chassis or ground. The maximum output voltage that can be supported between either output terminals and ground or chassis is 500 Vdc plus the maximum output voltage of the Power Module. Either terminal of the output may be grounded.

2.7.2 DC (OUTPUT) GROUNDING

DC output connections are those between the Power Module and the load, including remote sensing connections if necessary. Despite precautions to eliminate noise such as shielding and twisted wire-pairs, output connections may pick up radiated noise of a wide frequency. To minimize such undesired effects, one side of the Power Module output/load should be grounded.

Successful D.C. grounding depends on careful analysis of the system operation. However here, only general guide lines are provided. One of the major points, is to avoid ground loops. Ground loops are created when two or more points of different ground potentials in the output circuit are grounded. A noise voltage is developed that is superimposed on the load (output potential). A way to avoid ground loops is to investigate for points of resistance to ground. Differences in ground potential can be avoided if the output circuit is completely isolated. A single point is then selected along the Power Module output circuit and returned to ground with a single wire. This method is dependent on the specific application.

The MAT Power Modules are designed with Power Isolation relays that comply with MATE (Modular Automated Test Equipment) Test Module Adapter requirements. Each output is fully isolated from other outputs and from ground.

2.7.3 POWER MODULE TO LOAD INTERFACE

The general function of a voltage or current stabilized Power Module is to deliver rated output to the load. The load may be fixed or variable; resistive, capacitive, or inductive; and may be located close to or far away from the Power Module. The Power Module is designed for varied applications. The aim of the following paragraphs is to instruct the user in the interface of the Power Module to the load.

The perfect interface between a Power Module and load insures optimum performance. To approach this state of operation, one must be familiar with certain requirements, such as inter-connection guidelines, Ohm's Law and ac theory.

Load Wire Selection - A stabilized dc Power Module is not an ideal voltage or current source with zero output impedance (voltage mode) or infinite output impedance (current mode): All voltage sources have some amount of impedance which increases with frequency and all current sources have impedance which decreases with frequency. (See FIG. 2-4).

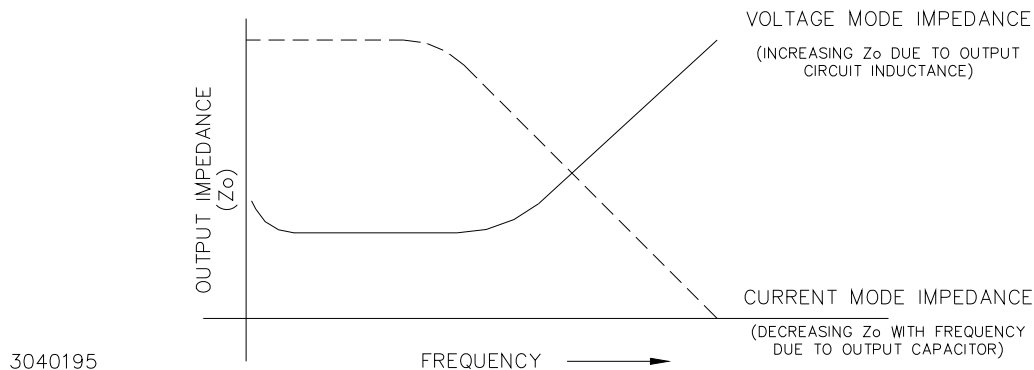

FIGURE 2-4. VARIATION OF OUTPUT IMPEDANCE WITH FREQUENCY FOR A VOLTAGE SOURCE AND A CURRENT SOURCE

A practical model for a voltage stabilized Power Module includes a series inductance representing dc and low frequency source impedance. Load leads should have minimum voltage drops (error sensing is discussed below) and minimum inductance (error sensing does not compensate for this). Similarly a model for a current stabilized Power Module includes a parallel capacitor representing the dc and low frequency source impedance.

These considerations are important if:

- 1) The load is constantly changing value
- 2) The load is switched "on" and "off"
- 3) The output of the Power Module is step programmed
- 4) The load is reactive
- 5) Dynamic output response of the Power Module is of concern

2.7.4 LOAD CONNECTION, LOCAL ERROR SENSING

The DC OUTPUT connector is located on the back of chassis, and is designated A6-J2 in the schematic. Table 2-6 and Figure 2-2 provide the function and location of DC OUTPUT connector pins.

NOTE: The sense terminals MUST be configured for either local sensing (as follows) or remote sensing (see PAR. 2.7.5) for the MAT Power Module to operate. If left unconnected the unit will automatically isolate the load and shut down.

For Local sensing connect Output Terminal 1 to Sense Terminal 1, and Output Terminal 2 to Sense Terminal 2 at the DC Output connector (see Figure 2-5).

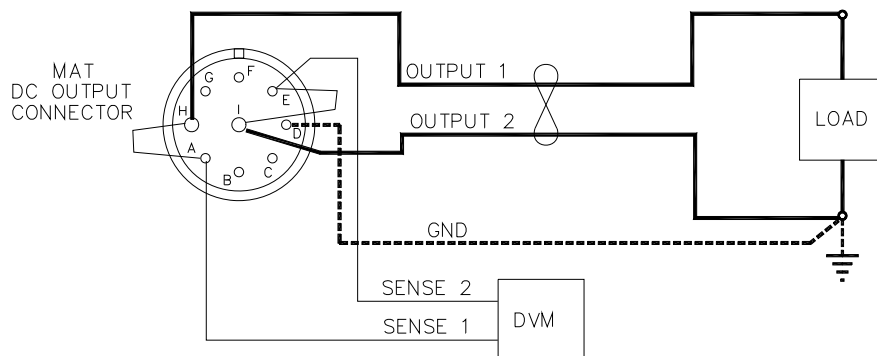

3041943

NOTE: DASHED LINE REPRESENTS GROUNDED LOAD CONNECTION.

FIGURE 2-5. LOAD CONNECTIONS, LOCAL SENSING

2.7.5 LOAD CONNECTION WITH REMOTE ERROR SENSING

The MAT series of Power Modules can operate with sensing external to the Module. Sensing should be with a twisted wire pair to reduce noise. The sensing wires must be connected as follows: Output terminal 1 to Sense Terminal 1 and Output Terminal 2 to Sense Terminal 2, each at the load (see Figure 2-6). Refer to Table 2-6 and Figure 2-2 for DC Output connector pin functions and locations.

When the MAT Power Module is connected for remote error sensing (in the voltage mode), a situation might occur where the output capacitor C14 must be supplemented to achieve optimum performance. If oscillations are observed at the output terminals or at the load, the load should be decoupled with another high quality capacitor of a value equal to or greater than C14.

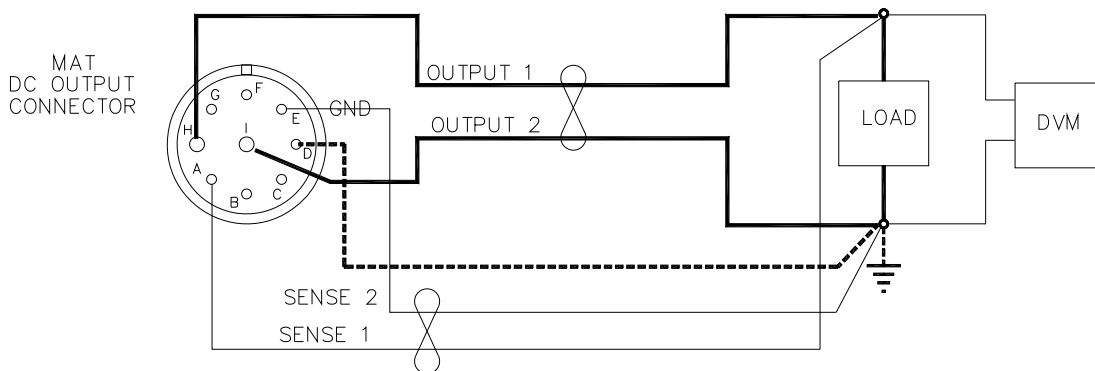

3041944

NOTE: DASHED LINE REPRESENTS GROUNDED LOAD CONNECTION.

FIGURE 2-6. LOAD CONNECTIONS, REMOTE SENSING

2.8 OPERATING CONFIGURATION

The complete operating configuration is defined by

- The Model Number (e.g. MAT 36-10)
- Jumper configuration of internal boards.

Table 2-4 lists the location of the internal jumpers and their function. This information is provided for reference purposes only, to indicate the configuration options available. Do not attempt to

alter the jumper configuration. For assistance in changing any jumper-selected parameter contact Kepco Applications Engineering.

TABLE 2-7. INTERNAL JUMPER CONFIGURATION

LOCATION	FUNCTION	JUMPER INSTALLED	JUMPER NOT INSTALLED	DESCRIPTION
A1	Establish the Model	J1-J5		MAT 6-32
		J1,J2,J3,J4	J5	MAT 15-20
		J1,J2,J3, J5	J4	MAT 25-14
		J1,J2-J3	J4 J5	MAT 36-10
		J1-J3	J4,J5	MAT 55-7
		J1,J2, J4	J3,J5	MAT 75-5
		J1, J2, J5	J3, J4	MAT 100-3.6
		J1,J2	J3-J5	MAT 150-2.4
	Path Fault Protection	J7		Enables crowbar protection circuit to trip circuit breaker and shut off unit if path fault detected.
			J7 (Default)	Allows software complete control of path fault protection. Outputs (voltage and current) are programmed to zero and relays opened to isolate load in case of path fault.
A2	Input Power Loss Protection	J5 (Default)		Enables crowbar protection circuit to trip circuit breaker and shut off unit when power loss detected.
			J5	Disables crowbar protection circuit which trips circuit breaker and shuts off unit when power loss detected.

2.9 PRELIMINARY CHECK-OUT

For a preliminary electrical check-out of the MAT Power Module a Host Computer, a Power Module Controller (see PAR. 1.2) and all the necessary interconnection cables are required. Connect the MAT Power Module DC Output connector for local sensing: Output 1 to Sense 1, Output 2 to Sense 2 (see Table 2-4). Connect a resistive load across Output 1 and Output 2 that is capable of dissipating the maximum current and voltage capabilities of the Power Module.

In this procedure the MAT Power Module Control Bus address is 3, (it is set at the factory to 3). Connect the Kepco Power Module Controller and the MAT Power Module (following check-out uses a Power Module Model MAT 36-10 as an example) to the Control Bus. Connect the Host Computer and the Power Module Controller to the IEEE 488 GPIB. Apply the ac power to the units in the following sequence: MAT Power Modules first and Power Module Controller last. In the event that this sequence is reversed (the Power Module Controller is connected first, and then the MAT Power Module is connected second) the operator must send a IEEE 488 GPIB Device Clear Interface Function via the Host Computer. For proper time delays between commands refer to PAR. 3.3. For details on the CIIIL commands refer to PAR. 3.6.3 and Appendix C as well as the Power Module Controller Manual. The following does not include the IEEE 488 Bus Commands.

1. To verify the Power Module is operational the Host Computer sends:

CNF (cr) (1 f)

- a. The Power Module Controller does self test

- b. All MAT Power Modules output enable relays open, all Power Modules go to maximum rating, and the Power Module Controller checks for error flags. After the test, the relays remain open and the Power Modules are set to zero.
2. To verify the CNF command was implemented, the Host Computer sends:

STA(cr)(lf)

The Power Module Controller sends back (if no errors occur)

(sp)(cr)(lf)

3. Proceed per PAR. 2.9.1 through 2.9.3 substituting full scale voltage/current values appropriate to the model being checked

2.9.1 EXAMPLE 1: FULL SCALE VOLTAGE CHECK

Program the Power Module MAT 36-10 to full scale voltage and check that the front panel meter reading and internal measured values are the same.

1. To program the Power Module to 36 volts, with a current limit of 10 amps the Host Computer sends:

FNC DCS :CH3 SET VOLT 36 SET CURL 10(cr)(lf)

The MAT at address 3, is now set to 36 volts, with a current limit of 10 amps.

2. To verify the FNC command was implemented, the Host Computer sends:

STA(cr)(lf)

The Power Module Controller sends back (if no errors occur):

(sp)(cr)(lf)

3. To measure the voltage at the output the Host Computer sends:

FNC DCS VOLT :CH3(cr)(lf)

The MAT at address 3 is now set to take a reading;

4. To take a reading the Host Computer sends:

INX VOLT(cr)(lf)

- a. The MAT previously set up now starts to measure and send the proper time delay needed for the measurement.
- b. The Power Module Controller will send the time delay value back to the Host Computer when it has been properly Talk Addressed (see specific IEEE 488 interface requirements):
00(cr)(lf)

- The Host Computer then sends:

FTH VOLT(cr)(lf)

- The MAT then sends the measured voltage in scientific notation to the Power Module Controller (for example 36.005 volts) which
- The Power Module Controller in turn sends:

3.6005E1(cr)(lf)

- Check that the front panel meter reading and the computer value are identical within the measurement tolerance. The meter selection switch must be set to "voltage" for a reading.

2.9.2 EXAMPLE 2: FULL SCALE CURRENT CHECK

Program the Power Module MAT 36-10 to full scale current and check that the front panel meter and internal measured values are the same.

- To program the Power Module to 10 amps, with a voltage limit of 36 volts, the Host Computer sends:

FNC DCS :CH3 SET CURR 10 SET VLTL 36(cr)(lf)

The MAT at address 3, is now set to 10 amps, with a voltage limit of 36 volts.

- To verify the FNC command was implemented, the Host Computer sends:

STA(cr)(lf)

The Power Module Controller sends back (if no errors occur):

(sp)(cr)(lf)

- To measure the current at the output the Host Computer sends:

FNC DCS CURR :CH3(cr)(lf)

The MAT at address 3 is now set to take a reading,

- To take a reading the Host Computer sends:

INX CURR(cr)(lf)

- The MAT previously set up now starts to measure and send the proper time delay needed for the measurement.
- The Power Module Controller will send the time delay value back to the Host Computer when it has been properly Talk Addressed (see specific IEEE 488 interface requirements):
00(cr)(lf)

5. The Host Computer then sends:

FTH CURR(cr)(lf)

- a. The MAT then sends the measured current in scientific notation to the Power Module Controller (for example 9.9998 amps) which
- b. The Power Module Controller in turn sends

9.9998E0(cr)(lf)

6. Check that the front panel meter reading and the computer are identical within their measurement tolerance. The meter selection switch must be set to "Current" for a reading.

2.9.3 EXAMPLE 3: TO RESET THE POWER MODULE

1. To reset the Power Module at address 3 the Host Computer sends:

RST DCS :CH3(cr)(lf)

2. To verify the RST command was implemented, the Host Computer sends:

STA(cr)(lf)

The Power Module Controller sends back (if no errors occur):

(sp)(cr)(lf)

3. This concludes the preliminary check-out of the MAT Power Module.

SECTION 3 - OPERATION

3.1 GENERAL

Interconnections linking a stabilized Power Module to an AC power source and a load are critical. For optimum performance certain rules must be observed. These rules are described in detail in the following paragraphs.

3.2 SERIES CONNECTION OF MAT POWER MODULES

When connecting MAT Power Modules in series, it is recommended that they be enabled and disabled in sequentially. That is to say the output enable relays will be closed or opened one immediately preceding the other. The Power Modules can be enabled or disabled in any order. The system Status must be checked after a Relay Enable or Disable Command is sent. The two MAT Power Module addresses in this example are 17 and 21.

To enable the Modules connected in series, the Host Computer sends:

```
CLS :CH17(cr)(lf)
STA(cr)(lf)
CLS :CH21(cr)(lf)
STA(cr)(lf)
```

To disable the Modules connected in series, the Host computer sends:

```
OPN :CH21(cr)(lf)
STA(cr)(lf)
OPN :CH17(cr)(lf)
STA(cr)(lf)
```

For parallel operation it is recommended that the user seek the manufacturer's assistance for specific applications.

3.3 POWER MODULE CONTROLLER/MAT TIME DELAYS (TO OBTAIN A VALID STATUS):

After sending a command that might affect the output of the Power Modules or their relays, it is recommended that the Status command be sent. For information on this command see the Power Module Controller Operator's Manuals. The required time delay before a valid status of the TMA/MAT system is as follows:

After an Open, Close, Change of Polarity, or Change of Mode wait approximately 300 milliseconds.

After a Confidence Test command or an Internal Self Test wait approximately 400 milliseconds.

After a Reset command wait approximately 300 milliseconds

After an INX Command the maximum delay time is 2 seconds

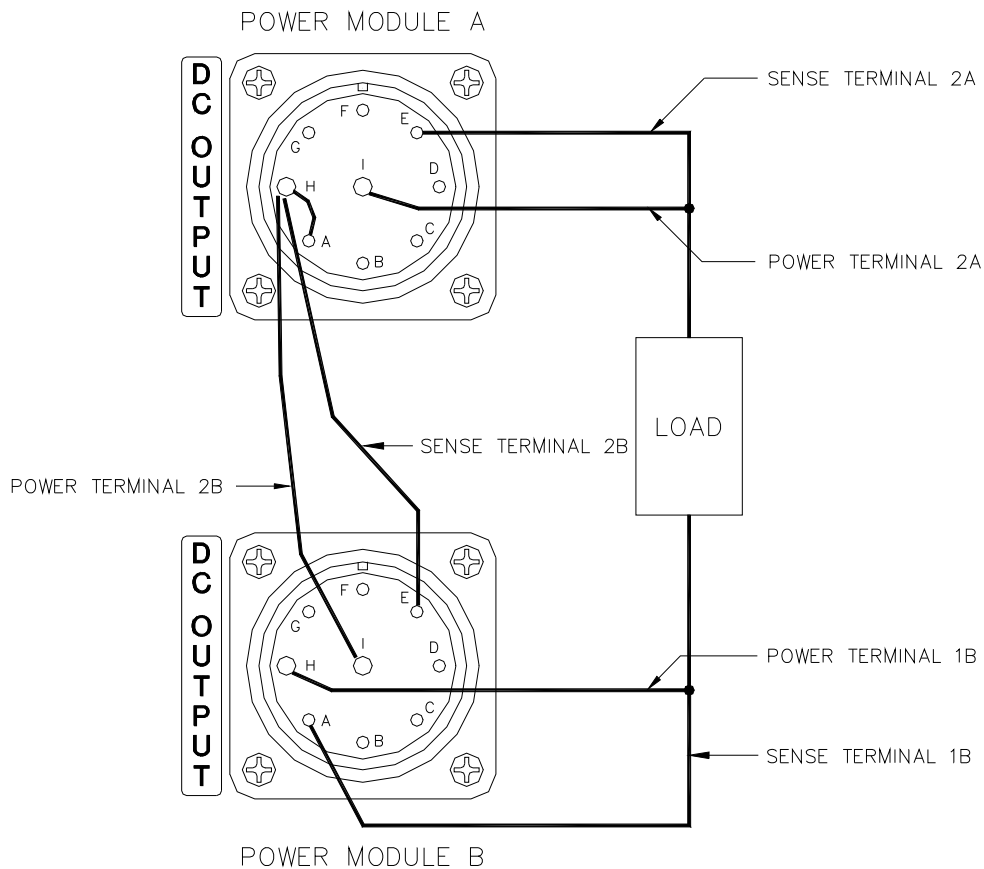

3041506

FIGURE 3-1. TWO MAT 1/3 RACK POWER MODULES CONNECTED IN SERIES VIA THEIR OUTPUT CONNECTOR

3.4 POWER LOSS CIRCUIT

An Automatic Shutdown option is available when a Power Loss is detected. Dependent on the setting of jumper J5 on the A2 Sense and Polarity Relay Board, the Power Module will shutdown automatically or remain in operation (see Figure 3-2). If the jumper is in place the AC Input Power circuit breaker will trip; if the jumper is removed the circuit breaker will not trip. The MAT Power Module is supplied with the jumper installed. To remove the jumper see Section 6 for PCB access, and Figure 3-2.

3.5 INTRODUCTION TO CONTROLLING THE MAT POWER MODULE OUTPUT

The MAT family of Power Modules communicates remotely with a controller via the Control Bus. Each MAT Power Module has a specific address on the bus. The address (from 1 to 30) is selected by the switches on the side of the unit (see FIG. 3-2 and Table 3-1). This address is set at Kepeco to 3.

The MAT family of Power Modules is controlled by the Power Module Controller (see PAR. 1.2). For an explanation of remote programming refer to PAR 3.6 and Appendix A, as well as the applicable Power Module Controller Manuals.

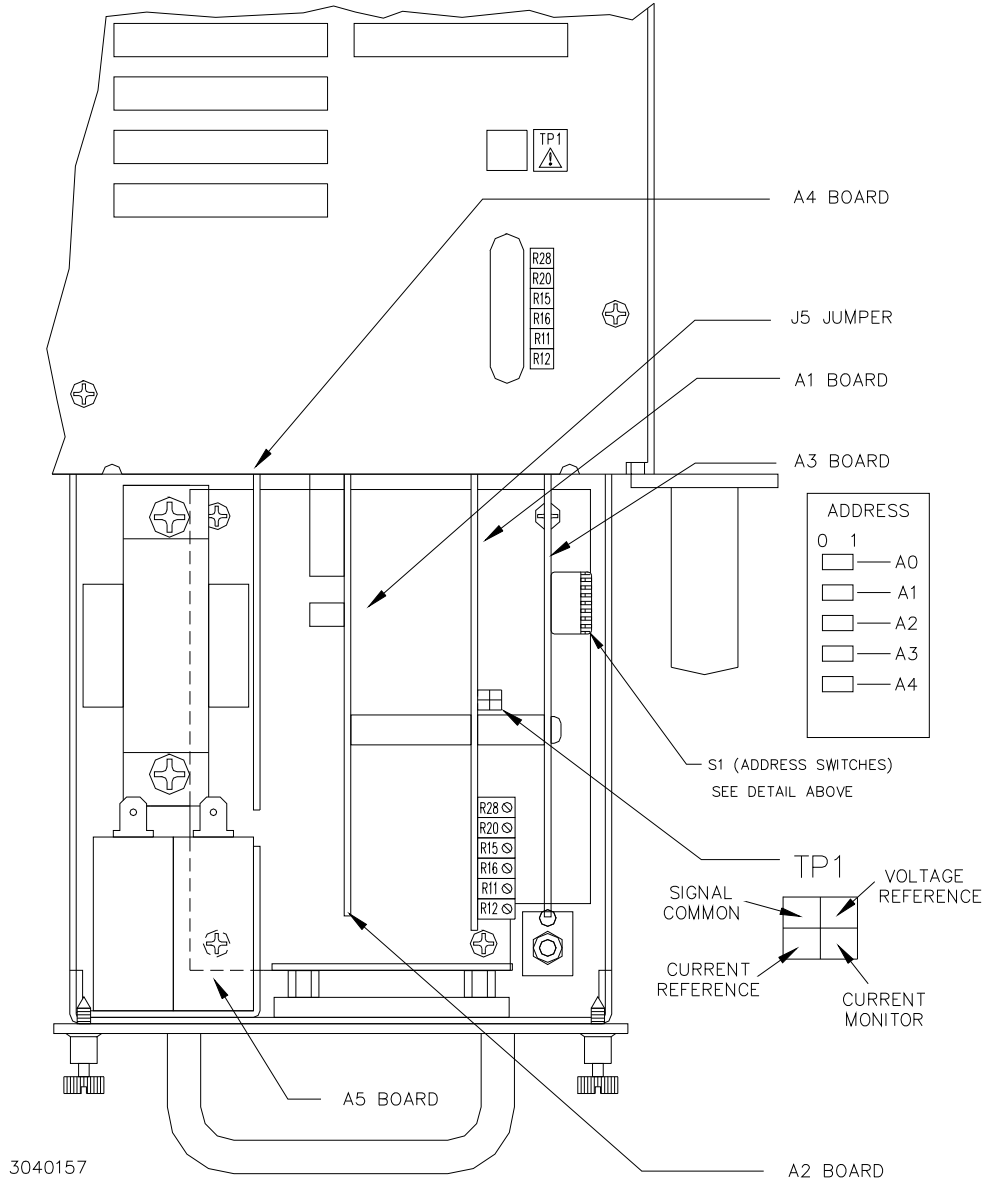

FIGURE 3-2. MAT POWER MODULE CONTROL SECTION, TOP COVER REMOVED

TABLE 3-1. DEVICE ADDRESS SELECTION FOR THE MAT POWER MODULE

DECIMAL ADDRESS	A3S1-4 (A4)	A3S1-3 (A3)	A3S1-2 (A2)	A3S1-1 (A1)	A3S1-0 (A0)
1	0	0	0	0	1
2	0	0	0	1	0
3	0	0	0	1	1
4	0	0	1	0	0
5	0	0	1	0	1
6	0	0	1	1	0
7	0	0	1	1	1
8	0	1	0	0	0
9	0	1	0	0	1
10	0	1	0	1	0
11	0	1	0	1	1
12	0	1	1	0	0
13	0	1	1	0	1
14	0	1	1	1	0
15	0	1	1	1	1
16	1	0	0	0	0
17	1	0	0	0	1
18	1	0	0	1	0
19	1	0	0	1	1
20	1	0	1	0	0
21	1	0	1	0	1
22	1	0	1	1	0
23	1	0	1	1	1
24	1	0	0	0	0
25	1	11	0	0	1
26	1	1	0	1	0
27	1	1	0	1	1
28	1	1	1	0	0
29	1	1	1	0	1
30	1	1	1	1	0
31	1	1	1	1	1

3.5.1 MAT/POWER MODULE CONTROLLER SYSTEM

MAT Power Modules are digitally controlled power supplies. Up to twenty seven Power Modules at a maximum distance of 1000 feet (300 meters) can be controlled by the Power Module Controller (see PAR. 1.2). The Power Module Controller communicates as a Talker/Listener with a Host Computer over the IEEE-488 GPIB using either the Standard Commands For Programma-

ble Instruments (SCPI) or the Control Interface Intermediate Language (CIIL). Refer to the Power Module Controller Operator's Manual for details regarding SCPI and CIIL commands. Communications with the MAT Power Modules are accomplished via a two-wire high speed (375 KHz) bidirectional serial communications bus, called the Control Bus.

The Power Module Controller is designed with a microcomputer board containing a relatively powerful CPU, 256K of RAM, programmable timers, priority interrupt circuits, an RS-232 input/output interface port and ROM firmware (embedded software). A discrete fault line is designed into the Power Module Controller to report catastrophic failures. Communications with an external terminal are achieved via an RS-232 communications bus and related interface card.

Power for the microcomputer board of the TMA 4882-27 Power Module Controller is provided by a wide range input Power Supply, Kepco Model MRW 150KV. The AC input voltage can range from 95 Volts AC to 264 Volts AC, thereby eliminating the need for an input voltage selector.

The IEEE-488 GPIB implements a number of Interface Functions from the IEEE-488 protocol (see the Power Module Controller Operator's Manual for details on these functions). The Power Module Controller microcomputer continuously polls all the Power Modules on the high speed Control Bus for any change in their Status conditions. A Status Monitor Interface Board is provided in the Power Module Controller as an interface to the Host Computer for reporting catastrophic failures within the Power Modules. If such an error is reported back to the Power Module Controller, the Host Computer then sends a Device Clear Command to open the isolation relays and reset all the Power Modules to zero. Following that, a Status command is sent to determine the nature of the failure. In Data Mode the Power Module Controller sends or receives messages per the IEEE 488 GPIB protocol. The messages are Enabled when the Attention line goes high. A Handshake cycle is performed for every ASCII character sent or received over the IEEE-488 GPIB.

3.5.2 MAT/TMA PC-27 SYSTEM

A Power Module Controller is available from Kepco that plugs directly into any DOS based computer to control the Power Modules (up to twenty seven Modules daisy-chained to a single Control Bus) without the need for an IEEE 488 GPIB. The use of the TMA PC-27 allows the Power Module Controller microcomputer board, the IEEE-488 GPIB interface input/output port and the RS 232 interface input/output port to be bypassed.

The TMA PC-27 Software can be loaded into a DOS based computer either as a Terminate and Stay (TSR) resident program, or as a stand-alone program. As a TSR it may be called from any of the following languages TURBO C, QUICK C, POWER C, TURBO PASCAL, QUICK PASCAL, QUICK BASIC and INTERPRETED BASIC.

With the TMA Software loaded, the MAT Power Modules may be programmed over the Control Bus using CIIL or KPL (Kepco Programming Language). KPL is a simplified command set based on CIIL. Catastrophic error messages will remain in memory until the cause of the failure is determined and the error condition is corrected. Additional functions not supported by CIIL have been included. A non-CIIL command, T0, calls for a noncatastrophic error message to be erased when a command other than Status is sent. A T1 command causes noncatastrophic error messages to be stacked in memory until interrogated by a Status command.

A programming language, referred to as KPL (Kepco Programming Language), is used to facilitate input/output operations for the TMA PC-27. It has embedded in it the software that supports the TMA PC-27 and is also compatible with National Instruments NI 488 DOS Handler for the IEEE-488 GPIB.

3.6 REMOTE PROGRAMMING

3.6.1 GENERAL

Kepeco MAT Power Supplies are programmed over a control bus using either SCPI (Standard Commands for Programmable Instruments) or CIIL (Control Interface Intermediate Language) commands. SCPI and CIIL provide a common language conforming to IEEE488.2 for instruments used in an automatic test system. The control bus can be either the IEEE 488 standard communication bus (General Purpose Interface Bus, GPIB), or the RS232C communication bus. Remote programming of the MAT requires connection to one of the controllers specified in PAR. 1-2.

3.6.2 SCPI PROGRAMMING

SCPI (Standard Commands for Programmable Instruments) is a programming language conforming to the protocols and standards established by IEEE 488.2 (reference document *ANSI/IEEE Std 488.2, IEEE Standard Codes, ForMATS, Protocols, and Common Commands*). SCPI commands are sent to the MAT Power Supply as output strings within the selected programming language (PASCAL, BASIC, etc.) in accordance with the manufacturer's requirements for the particular GPIB interface card used and the Kepeco controller selected (see PAR 1-2.)

Figure 3-3 illustrates typical SCPI commands used for remote programming of the MAT power supply. For the complete command set, and detailed SCPI programming information, consult the Technical Manual for the applicable controller (the SCPI command sets among Kepeco controllers are slightly different). See PAR.3.5 to establish the MAT power supply Control Bus (BIT-BUS) address.

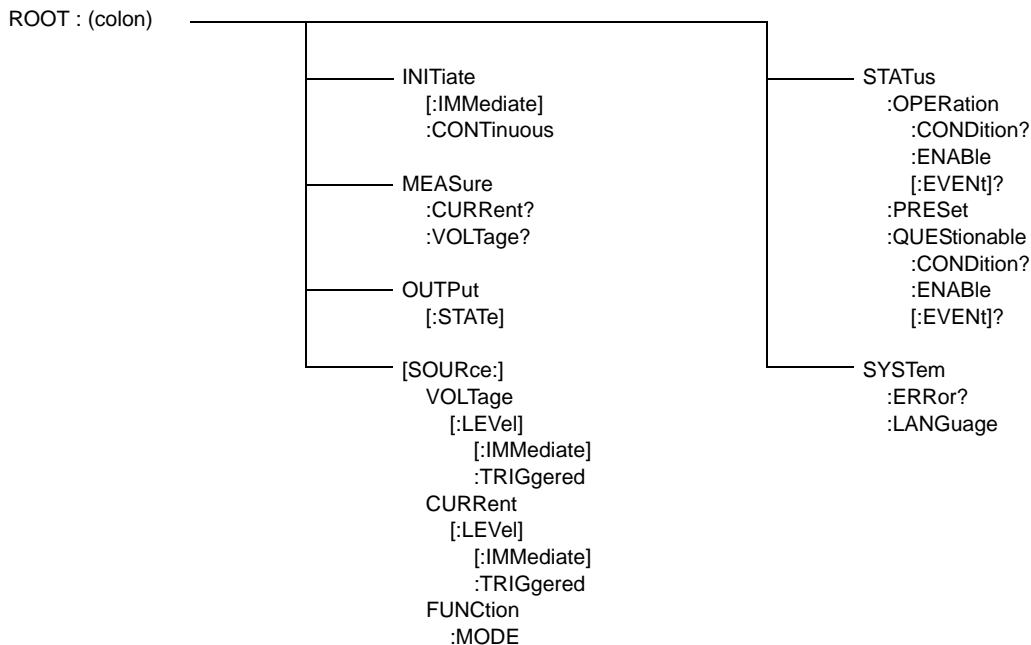

FIGURE 3-3. TREE DIAGRAM OF SCPI COMMANDS USED WITH MAT POWER SUPPLIES

3.6.2.1 SCPI PROGRAM EXAMPLE

Figure 3-4 is an example of a program using SCPI commands to program the MAT Power Supply. The program illustrated is for a configuration using an IBM PC or compatible with a National Instruments GPIB interface card. (It will be necessary to consult the manufacturer's data to achieve comparable functions with an interface card from a different manufacturer.) This program sets output voltage (Voltage mode) or voltage limit (Current mode) to 5V, and current limit (Voltage mode) or output current (Current mode) to 1A, then reads the measured (actual) voltage and current, then prints the measurements.

```

/*****
/*   Sample Program For KEPCO power supply, using National Instruments   */
/*   GPIB interface card and IBM PC or compatible computer               */
/*****

#include <stdio.h>
#include "decl.h"

char rd_str[80];           // Input buffer
char dat_str[80];         // Output buffer
int  bd,adr;

main() {
    adr = ibfind("DEV6");   // Open DEV6 (defined by IBCONF)
    bd = ibfind ("GPIB0"); // Open GPIB card
    ibsic (bd);             // Send Interface Clear
    ibsre(bd,1);           // Set remote line true

    strcpy(dat_str,"VOLT 5;CURR 1"); // Define a set command
    strcat(dat_str,"\r\n");          // Append delimiter
    ibwrt(adr,dat_str,strlen(dat_str)); // Send string to power supply

    strcpy(dat_str,"MEAS:VOLT?;CURR?"); // Define a measure command
    strcat(dat_str,"\r\n");          // Append delimiter
    ibwrt(adr,dat_str,strlen(dat_str)); // Send string to power supply

    strset(rd_str,'\0');           // Clear input buffer
    ibrd(adr,rd_str,64);           // Read result of measure
    printf("received : %s\n",rd_str); // Print voltage and current
}

```

FIGURE 3-4. TYPICAL EXAMPLE OF MAT POWER SUPPLY PROGRAM USING SCPI COMMANDS

3.6.3 CIIL PROGRAMMING

The CIIL command language is used on early models of Kepco power supplies and controllers. The command functions are included here for compatibility with other equipment programmed with CIIL commands. The CIIL command set for the MAT Power Supply is defined and explained in Appendix C.

CIIL is the test instrumentation module programming language standard for all new Air Force MATE test equipment programs. CIIL is a subset of a higher level language used in automatic test equipment systems, ATLAS (Abbreviated Test Language for All Systems).

The CIIL statements sent to monitor and program Power Modules consist of CIIL operation codes, nouns and noun modifiers, with data values expressed as ASCII integer, decimal or in scientific notation.

3.6.3.1 EXAMPLES USING CIIL TO PROGRAM THE MAT POWER MODULE.

The following examples show the use of CIIL (Control Interface Intermediate Language). They do not show the IEEE 488 bus commands from the Host Computer to the Power Module Controller nor do they show the proper time delays (refer to PAR. 3.3). The examples are for a MAT 55-7 model with Control Bus address 9. The ASCII characters for space, carriage return and line feed are represented as (sp), (cr) and (lf) respectively. The MAT Power Module, the Power Module Controller, a Host Computer, and the IEEE 488 must be interconnected for this routine

Note: Make sure the sense leads are connected to their respective load leads. When output current is programmed, a load must be connected at the output terminals.

1. To verify the Power Module, is operational, the Host Computer sends:

```
CNF(cr)(lf)
```

The Power Module Controller does self test All MAT Power Module output relays are disabled, all Power Modules go to maximum ratings and the Power Module Controller checks for error flags. After the test, the relays remain disabled and the Power Modules are then set to zero.

2. To verify the CNF command was implemented the Host Computer sends:

```
STA(cr)(lf)
```

The Power Module Controller sends back (if no errors occur):

```
(sp)(cr)(lf)
```

3.6.3.1.1 EXAMPLE 1: PROGRAM POSITIVE VOLTAGE WITH CURRENT LIMIT

1. To program the Power Module MAT 55-7 to 50 volts with a current limit of 3 amps, the Host Computer sends:

```
FNC DCS :CH9 SET VOLT 50 SET CURL 3(cr)(lf)
```

The MAT at address 9, is then set to 50 volts, with a current limit of 3 amps

2. To verify the previous command was implemented the Host Computer sends:

STA(cr)(lf)

The Power Module Controller sends back (if no errors occur)

(sp)(cr)(lf)

3. To close the Output Enable relay (connects the Power Module to the load) the Host Computer sends

CLS :CH9(sp)(lf)

The Power Module at address 9, closes the relay

4. To verify the previous command was implemented the Host Computer sends:

STA(cr)(lf)

The Power Module Controller sends back (if no errors occur):

(sp)(cr)(lf)

5. To measure the current at the output the Host Computer sends:

FNC DCS CURR :CH9(cr)(lf)

The MAT at address 9 is now set to take a reading

6. To take a reading the the Host Computer sends:

INX CURR(cr)(lf)

- a. The MAT previously set up now starts to measure and sends the proper time delay needed for the measurement
- b. The Power Module Controller will send the time delay back to the Host Computer when it has been Talk Addressed (see specific IEEE 488 interface requirements):
00(cr)(lf)

7. The Host Computer then sends:

FTH CURR(cr)(lf)

- a. The MAT then sends the measured current in scientific notation to the Power Module Controller (for example 1.9598 amps)
- b. The Power Module Controller in turn sends:

1.9598E0(cr)(lf)

8. To open the Output Enable relay (disconnect the load from the Power Module), the Host Computer sends:

```
OPN :CH9(cr)(lf)
```

The Power Module relay at address 9 is open

9. To verify the previous command was implemented, the Host Computer sends:

```
STA(cr)(lf)
```

The Power Module Controller sends back (if no errors occur)

```
(sp)(cr)(lf)
```

3.6.3.1.2 EXAMPLE 2 : PROGRAM NEGATIVE VOLTAGE WITH CURRENT LIMIT

1. To program the Power Module MAT 55-7 to -45 volts with a current limit of 2 amps, the Host Computer sends:

```
FNC DCS :CH9 SET VOLT -45 SET CURL 2(cr)(lf)
```

The MAT at address 9, is then programmed to -45 volts, with a current limit of 2 amps

2. To verify the previous command was implemented the Host Computer sends:

```
STA(cr)(lf)
```

The Power Module Controller sends back (if no errors occur):

```
(sp)(cr)(lf)
```

3. To enable output (connect the load to the Power Module), the Host Computer sends:

```
CLS :CH9 (sp)(lf)
```

The Power Module relay at address 9, closes

4. To verify the previous command was implemented the Host Computer sends:

```
STA(cr)(lf)
```

The Power Module Controller sends back (if no errors occur):

```
(sp)(cr)(lf)
```

5. To measure the voltage at the output, the Host Computer sends:

```
FNC DCS VOLT :CH9(cr)(lf)
```

The MAT at address 9 is now set to take a reading

6. To take reading the Host Computer sends:

INX VOLT(cr)(lf)

- a. The MAT previously set up now starts to measure and sends the proper time delay needed for the measurement
- b. The Power Module Controller will send the time delay back to the Host Computer when it has been Talk Addressed (see specific IEEE 488 interface requirements):
00(cr)(lf)

7. The Host Computer then sends:

FTH VOLT(cr)(lf)

- a. The MAT then sends the measured (in the example it is -45.01 volts) voltage in scientific notation to the Power Module Controller
- b. The Power Module Controller in turn sends

-4.5010E1(cr)(lf)

8. To reset the Power Module at address 9 the Host Computer sends:

RST DCS :CH9(cr)(lf)

The MAT then programs the output to zero and opens the Output Enable relay.

9. To verify the previous command was implemented the Host Computer sends:

STA(cr)(lf)

The Power Module Controller sends back (if no errors occur)

(sp)(cr)(lf)

3.6.3.1.3 EXAMPLE 3: PROGRAM CURRENT AND VOLTAGE LIMIT

1. To program the MAT Power Module MAT 55-7 in current mode with a current of 4 amps and a voltage limit of 30 volts, the Host Computer sends:

FNC DCS :CH9 SET CURR 4 SET VLTL 30(cr)(lf)

The MAT at address 9, is then set up as a current source giving 4 amps with a voltage limit of 30 volts

2. To verify the previous command was implemented the Host Computer sends:

STA(cr)(lf)

The Power Module Controller sends back (if no errors occur):

(sp)(cr)(lf)

3. To enable the output, the Host Computer sends:

`CLS :CH9(cr)(lf)`

4. To verify the previous command was implemented the Host Computer sends:

`STA(cr)(lf)`

The Power Module Controller sends back (if no errors occur):

`(sp)(cr)(lf)`

5. To measure the current at the output the Host Computer sends:

`FNC DCS CURR :CH9(cr)(lf)`

The MAT at address 9 is now set to take a reading

6. To take a reading the Host Computer sends

`INX CURR(cr)(lf)`

- a. The MAT previously set up now starts to measure and sends the proper time delay needed for the measurement (See Par. 3.3).
- b. The Power Module Controller will send the time delay back to the Host Computer when it has been Talk Addressed (see specific IEEE 488 interface requirements):

`00(cr)(lf)`

7. The Host Computer then sends

`FTH CURR(cr)(lf)`

- a. The MAT then sends the measured (in the example it is 3.9998 volts) current in scientific notation to the Power Module Controller
- b. The Power Module Controller in turn sends:

`3.9998E0(cr)(lf)`

8. To measure the voltage at the output, the Host Computer sends:

`FNC DCS VOLT :CH9(cr)(lf)`

The MAT at address 9 is now set to take a reading

3.7 MAT CALIBRATION PROCEDURE

MAT Power Modules are factory calibrated and do not require periodic recalibration. Calibration is required only after repair, or if output readings are suspect. To calibrate an MAT Power Module the following items are needed: a Power Module Controller (see PAR. 1.2), a Voltmeter (accurate to at least 0.1 millivolt), a precision shunt, and all cables needed to connect the Power Module Controller, MAT Power Module and load.

NOTE: $E_{o\ max}$ and $I_{o\ max}$ must be replaced with numerical values that represent the maximum output voltage ($E_{o\ max}$) and maximum output current ($I_{o\ max}$) respectively of the unit under test. For example, for a MAT 36-10 unit $E_{o\ max} = 36\ Vdc$ and $I_{o\ max} = 10\ A$.

3.7.1 E/I ZERO CALIBRATION

The following procedure requires commands to be issued by the host computer in order to program the power module or read back information (voltage, current or status) from the power module; it does not include the IEEE 488 Bus Commands.

1. Turn ON the MAT Module. If the unit is in current mode (current LED is on) turn R28 counterclockwise until the Power Module switches into the voltage mode (voltage LED is on). Voltage and current LED's are located on the Front Panel.
2. Connect a precision Digital Voltmeter referenced to the current monitor and signal common terminals of TP1 (see Figure 3-5). Adjust R15 so that the voltage measured is $0\ Vd-c \pm 0.5mV$. If during this procedure the current LED turns on, readjust R28 (turn R28 counterclockwise) until the unit switches back into the voltage mode.

NOTE A: This procedure provides specific SCPI and CIIL commands where necessary to implement the applicable step. These commands are for a $E_{o\ max}$, $I_{o\ max}$ MAT Model, set to Control Bus Address 1 (the factory default setting is 3); for addresses other than 1, change commands accordingly (refer to PAR. 3.6.2 for SCPI, PAR. 3.6.3 and Appendix A for CIIL, and the applicable Power Module Controller Instruction Manual for details).

NOTE B: Make sure that the load is disconnected and the error sensing terminals are connected to their respective output terminals.

3. Issue commands from the host computer to initialize the Power Module.

SCPI COMMANDS	CIIL COMMANDS
*RST	DCL

4. Issue commands from the host computer to enable the output.

SCPI COMMANDS	CIIL COMMANDS
OUTP ON	CLS :CH1

5. Connect a precision Digital Voltmeter to the rear Output Connector Error Sensing terminals (see Table 2-6 and Figure 2-2). Adjust R20 until the measured voltage is $0\ Vd-c \pm 0.5mV$.

NOTE: If the CURRENT MODE LED lights during adjustment of R20, turn R28 counterclockwise until the CURRENT MODE LED goes off, then readjust R20 per step 5 above.

6. Disable the output of the unit by sending the following command.

SCPI COMMANDS	CIIL COMMANDS
OUTP OFF	OPN :CH1

7. Send the following commands to set current to 0 and voltage limit to $E_{o\ max}$

SCPI COMMANDS	CIIL COMMANDS
FUNC1:MODE CURR VOLT1 $E_{o\ max}$; CURR1 0;	FNC DCS :CH1 SET CURR 0 SET VLTL $E_{o\ max}$

8. Connect a precision Digital Voltmeter at the current monitor and signal common terminals of TP1 (see Figure 3-5). Adjust R28 until the voltage measured is -3.5 mV to -4mV.

NOTE: The CURRENT MODE LED should stay on during adjustment of R28.

9. Proceed to E/I full scale calibration (see PAR. 3.7.2).

3.7.2 E/I FULL SCALE CALIBRATION

The following procedure requires that E/I zero calibration (PAR. 3.7.1) be performed first.

1. Connect a precision Digital Voltmeter to the rear output Connector Error Sensing terminals (see Figure 3-2 and Table 3-2). At this time the load should be disconnected and the Error Sensing terminals should be connected to the corresponding power output terminals.

2. Send the following commands to set voltage to $E_{o\ max}$ and current limit to $I_{o\ max}$:

SCPI COMMANDS	CIIL COMMANDS
FUNC1:MODE VOLT VOLT1 $E_{o\ max}$; CURR1 $I_{o\ max}$;	FNC DCS :CH1 SET VOLT $E_{o\ max}$ SET CURL $I_{o\ max}$

3. Enable the output of unit

SCPI COMMANDS	CIIL COMMANDS
OUTP ON	CLS :CH1

4. Adjust R11 until the voltage measured by the voltmeter is $E_{o\ max} \pm \frac{E_{o\ max}}{2 \times 4095}$

5. Disable the output by sending the RESET command

SCPI COMMANDS	CIIL COMMANDS
*RST	DCL

6. Make sure that the load is disconnected and the error sensing terminals are connected to their respective output terminals. Connect a precision digital Ammeter to the rear Output Connector Output terminals (see Figure 2-2 and Table 2-6)

7. Send the following command to set $I_{o\ max}$ and the voltage limit to $E_{o\ max}/5$:

SCPI COMMANDS	CIIL COMMANDS
FUNC1:MODE CURR VOLT1 $E_{o\ max}/5$; CURR1 $I_{o\ max}$;	FNC DCS :CH1 SET CURR $I_{o\ max}$ SET VLTL $E_{o\ max}/5$

8. Connect a precision Digital Voltmeter to the current monitor of TP1 referenced to the signal common (see Figure 3-5). Adjust R12 until the voltage measured is $-5.000\ Vdc \pm 0.5mV$.

9. Enable the output

SCPI COMMANDS	CIIL COMMANDS
OUTP ON	CLS :CH1

10. Adjust R16 until the measured output current by the external ammeter is

$$I_{o\ max} \pm \frac{I_{o\ max}}{2 \times 4095}$$

11. Disable the output by sending Reset command

SCPI COMMANDS	CIIL COMMANDS
*RST	DCL

12. Disconnect the Digital Ammeter and the Digital voltmeter.

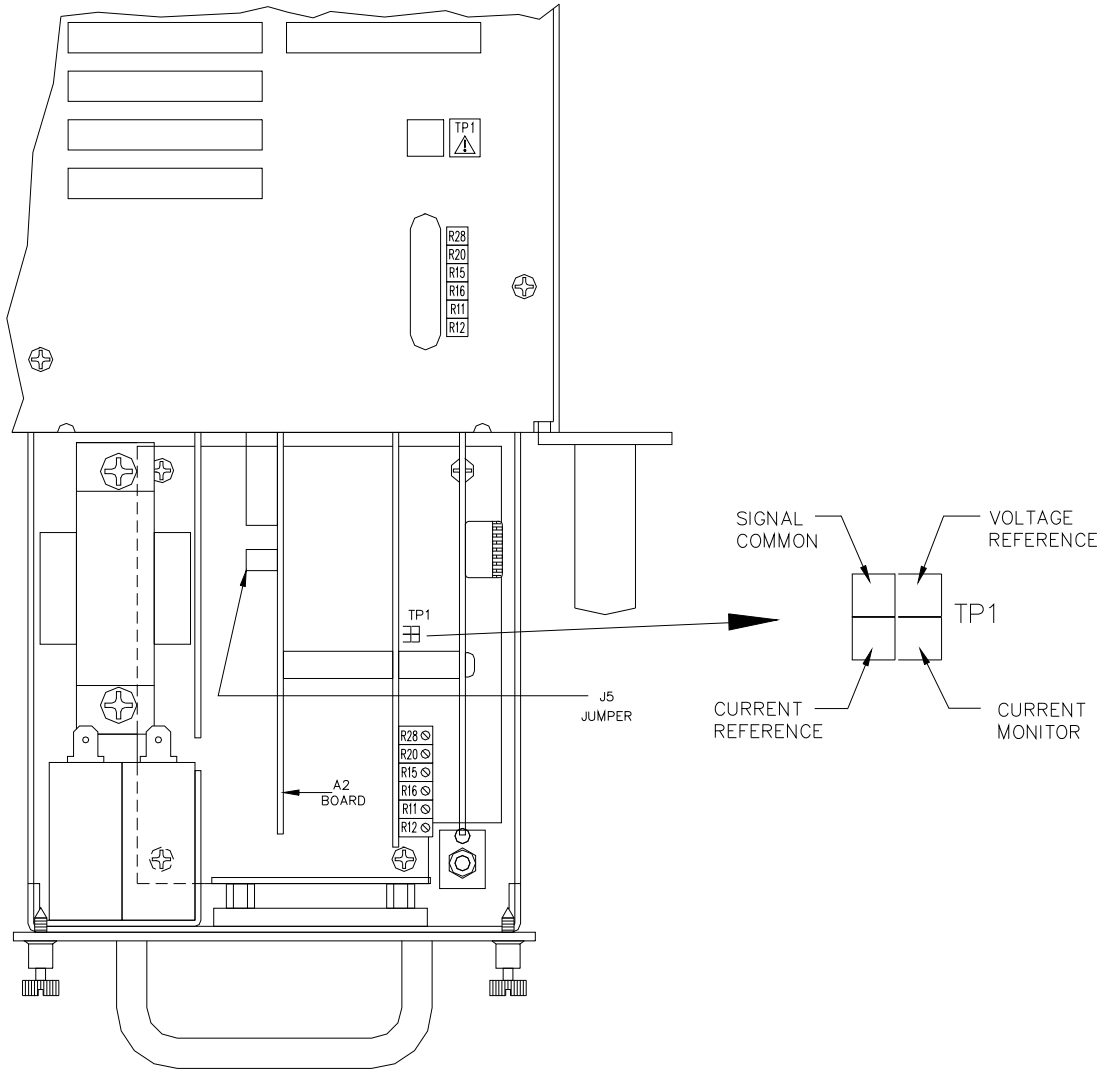

FIGURE 3-5. MAT POWER MODULE CALIBRATION REQUIRES ADJUSTMENT OF THE ABOVE CONTROLS

APPENDIX A - CIIL COMMAND DEFINITIONS

A.1 INTRODUCTION

This appendix defines the CIIL commands used with the MAT Power Supply. Table C-1 provides a quick reference of all CIIL commands used in the MAT Power Supply.

TABLE A-1. CIIL SUBSYSTEM COMMAND/QUERY INDEX

COMMAND	PAGE	COMMAND	PAGE
CLS	C-4	OPN	C-4
CNF	C-4	RST	C-4
FNC	C-1	SET	C-3
FTH	C-2	SRN	C-3
INX	C-2	SRX	C-3
IST	C-4	STA	C-5

FNC

Syntax: Stimulus mode: FNC DCS :CHnn <SET Command>
 Sensor mode: FNC DCS <VOLT or CURR command> :CHnn

Function: This operator is used with either the SET command to program a power supply's output (stimulus mode), or with the VOLT and CURR commands to read its output settings (sensor mode).

Description: The first operand contains the three (3) letter mnemonic pertaining to the device on the control bus, in this case DCS (Direct Current Source). If a reading is being set up, the modifier VOLT or CURR follows. The next operand is used to select the specific channel of the device being programmed or read from. The MAT can control up to 27 power supplies/power modules with control bus addresses in the range of 1 to 31.

Example:

FNC DCS :CH12 SET VOLT 15 FNC DCS :CH12 SET CURR 3 FNC DCS VOLT :CH03 FNC DCS CURR :CH21	Power supply at node address 12 commanded to 15V Power supply at node address 12 commanded to 3A Power supply at node address 3 returns value which represents actual output voltage Power supply at node address 21 returns value which represents actual output current
---	--

NOTE: Actual output voltage and current depends on whether output is enabled or disabled and load conditions

FIGURE A-1. FNC — Function Command

INX

- Syntax:** INX VOLT (initiate voltage reading)
INX CURR (initiate current reading)
- Function:** Commences a data acquisition process in accordance with the preceding FNC command.
- Description:** The response to the INX command is a dynamic time-out value, unless a catastrophic error condition exists, in which case an error message will be returned. If the time-out value returned is not zero, this indicates the power supply's output voltage or current has not yet settled. A time delay should be observed before proceeding with the FTH command, or the command may be repeated until a zero value is returned, but the preceding FTH command must also be repeated.
- Example:** INX VOLT Power supply initiates voltage reading)
FTH VOLT Power supply sends voltage reading to controller)

FIGURE A-2. INX — Initiate Op Code Command

FTH

- Syntax:** FTH VOLT (fetch voltage reading)
FTH CURR (fetch current reading)
- Function:** Commands the previously designated power supply to return the requested data reading.
- Description:** This command must immediately follow an INX command. The value returned is the value of the output voltage or current, whichever was requested, unless a catastrophic error condition exists, in which case an error message will be returned. The value observed will be in scientific notation.
- Example:** INX VOLT Power supply initiates voltage reading)
FTH VOLT Power supply sends voltage reading to controller)

FIGURE A-3. FTH — Fetch Command

OPN, CLS

Syntax:	OPN :CHnn CLS :CHnn
Function:	These commands are used to connect or disconnect the power supply from the load (effective for MR and MGR options only).
Description:	OPN Disconnects the load from the power supply specified by the operand. CLS Connects the load to the power supply specified by the operand.
Example:	OPN :CH22 Opens the relay of the power supply at node address 22. CLS :CH14 Closes the relay of the power supply at node address 14.

FIGURE A-5. OPN, CLS — Open, Close Relay Commands

RST

Syntax:	RST DCS :CHnn
Function:	This operator is used to return a power supply to its power-on state. The output voltage and current are programmed to zero and the output relay of MR and MGR models is opened.
Example:	RST DCS :CH13 The power supply at node address 13 is reset.

FIGURE A-6. RST — Reset Command

CNF, IST

Syntax:	CNF or IST
Function:	Causes power supply to execute confidence test.
Description:	The CNF operator commands the MAT to execute the confidence test procedure defined for the MAT power supplies (IST is functionally identical to CNF for MAT power supplies. The procedure consists of opening all power relays, programming voltage and current to their maximum values, switching polarity, checking for error flags, then programming voltage and current to zero. The results of CNF are obtained through the STA command.
Example:	CNF All power supplies in the daisy chain execute confidence test. IST All power supplies in the daisy chain execute self test.

FIGURE A-7. CNF, IST — Confidence Test, Internal Self Test Commands

STA

Syntax: STA

Function: Causes power supply to return operating status to controller.

Description: This operator commands the power supply to report its present operating status. Status is reported in the form of a message (character string) as defined below. Any catastrophic error conditions (indicated by * in the table below) which exist will be reported, until the error condition is corrected. As required by CIIL, all error messages begin with an ASCII "F" (Fault) followed by a 2 digit code, "07" (Halt). The code that follows (SCSnn) indicates the type of device and the channel number. The next 3 digit code describes the nature of the fault: "DEV" for device related errors or "MOD" for non-device errors, such as syntax.

TABLE A-2. CIIL ERROR MESSAGES

ERROR MESSAGE	EXPLANATION
F07 DCSnn DEV Power Loss	The power supply has lost its input power. *
F07 DCSnn DEV Crowbarred (MAT, MAT)	A shutdown occurred due to overvoltage or overcurrent. *
F07 DCSnn DEV Device Turned Off (BOP)	
F07 DCSnn DEV Output Fault (MST)	
F07 DCSnn DEV Over Temperature	A shutdown occurred due to thermal causes. *
F07 DCSnn DEV Overload	The voltage or current limit point was exceeded. *
F07 DCSnn DEV Voltage Fault	The output voltage is not within limits (voltage mode). *
F07 DCSnn DEV Current Fault	The output current is not within limits (current mode). *
F07 DCSnn DEV Relay Not Opened	The power relay failed to open. *
F07 DCSnn DEV Relay Not Closed	The power relay failed to close. *
F07 DCSnn DEV Polarity Error	The output polarity is not correct. *
F07 DCSnn DEV Load Path Fault	Open or miswired load or error sense leads detected. *
F07 DCSnn MOD Invalid Command	Improper syntax was used. **
F07 DCSnn DEV Not Ready	The output voltage or current has not settled. **
F07 DCSnn DEV Device Not Present	The specified power supply was not present during power up or during the last DCL. **
F07 DCSnn DEV Device Not Responding	The power supply has failed to communicate to the controller. **
F07 DCSnn DEV Invalid Voltage Range	The programmed voltage is outside the power supply's range. **
F07 DCSnn DEV Invalid Current Range	The programmed current is outside the power supply's range. **
F07 DCSnn DEV Set Modifier Error	An improper SET command was sent. **
F07 DCSnn DEV Invalid Device ID	The selected channel was not between 1-31. **
* Catastrophic error	
** Non-Catastrophic error	

FIGURE A-8. STA — Status Command

