

# INSTRUCTION MANUAL

## PRR 28-36 POWER SUPPLY

KEPCO INC.  
An ISO 9001 Company.

### MODEL PRR 28-36M POWER SUPPLY

ORDER NO.

REV. NO

#### IMPORTANT NOTES:

- 1) This manual is valid for the following Model and associated serial numbers:

| MODEL | SERIAL NO. | REV. NO. |
|-------|------------|----------|
|-------|------------|----------|

- 2) A Change Page may be included at the end of the manual. All applicable changes and revision number changes are documented with reference to the equipment serial numbers. Before using this Operator's Manual, check your equipment serial number to identify your model. If in doubt, contact your nearest Kepco Representative, or the Kepco Documentation Office in New York, (718) 461-7000, requesting the correct revision for your particular model and serial number.
- 3) The contents of this manual are protected by copyright. Reproduction of any part can be made only with the specific written permission of Kepco, Inc.

Data subject to change without notice.

©2018, KEPCO, INC  
P/N 243-0504-r1



KEPCO, INC. • 131-38 SANFORD AVENUE • FLUSHING, NY. 11355 U.S.A. • TEL (718) 461-7000 • FAX (718) 767-1102  
email: [hq@kepcopower.com](mailto:hq@kepcopower.com) • World Wide Web: <http://www.kepcopower.com>



## DESCRIPTION (Refer to FIG. 1)

The Kepco PRR group of power supplies are fixed d-c voltage sources delivering approximately 1000 Watts of output power. The design of the PRR supplies is based on Kepco's patented FLUX-O-TRAN<sup>®</sup> ferroresonant power transformer. PRR models can be operated either from domestic 120V a-c, 60 Hz power lines (models without suffix) or from foreign 230V a-c, 50 Hz sources (models with suffix "-50"). PRR power supplies are constructed in full-rack width and can be installed directly, or by means of slides, into standard (19-inch) equipment racks. PRR power sources are completely short-circuit proof, due to automatic current limiting of the ferroresonant power transformer at 125 to 150% of the rated output current.

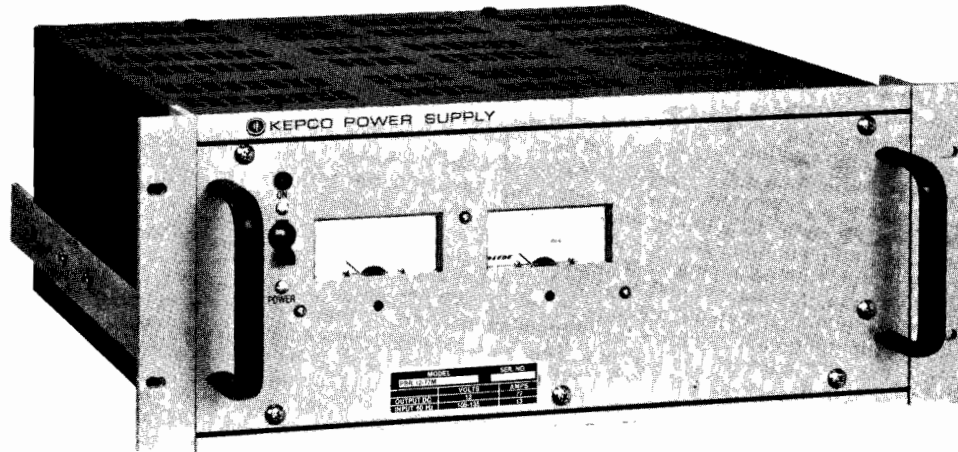

FIG. 1 KEPCO PRR POWER SUPPLY. FRONT VIEW.

## SPECIFICATIONS, ELECTRICAL

A-C INPUT (PRR MODELS WITHOUT SUFFIX): 120V a-c,  $\pm 15V$  a-c, 60 Hz  $\pm 5\%$ <sup>(1)</sup> single phase, 15A max.

A-C INPUT (PRR MODELS WITH SUFFIX "-50"): 230V a-c  $\pm 30V$  a-c, 50 Hz  $\pm 5\%$ <sup>(1)</sup>, single phase, 6A max.

<sup>(1)</sup> A 1% change in source frequency produces from 1 to 1.5% output voltage change.

D-C OUTPUT RANGE: See Table 1.

LOAD EFFECT: See Table 1 and applicable load effect curve in FIG. 2.

RIPPLE and NOISE: See Table 1 for maximum rms values and the graph in FIG. 3 for typical data.

SOURCE EFFECT: Less than  $\pm 1\%$  (0.5% typical) of the rated output voltage for rated change in source voltage, with any load from 10-100% of the rated value.

OUTPUT VOLTAGE ACCURACY: Within  $\pm 2\%$ , or 0.25V, whichever is greater, of the specified output voltage, at nominal source voltage, 30°C ambient temperature, at maximum load and following a 30-minute warm-up period. Allow for an initial (cold) voltage approximately 1% higher than the specified output voltage accuracy. The output voltage increase at output current levels less than the maximum rated may be read from the load effect curves (FIG. 2) and must be added to the nominal output level.

OPERATING TEMPERATURE:  $-20^{\circ}\text{C}$  to  $+55^{\circ}\text{C}$ .

STORAGE TEMPERATURE:  $-40^{\circ}\text{C}$  to  $+85^{\circ}\text{C}$ .

TEMPERATURE EFFECT COEFFICIENT: Less than 0.05% output voltage change per  $^{\circ}\text{C}$ .

TIME EFFECT (8-hour drift): Less than 1% or 0.1 mV, whichever is greater, output voltage change.

| MODEL         | D-C OUTPUT |      | LOAD EFFECT (VOLTS INCREASE) |               | LOAD EFFECT CURVE | RIPPLE (max) RMS VOLTS | SHIP WGT. |      |
|---------------|------------|------|------------------------------|---------------|-------------------|------------------------|-----------|------|
|               | VOLTS      | AMPS | 100%-50% LOAD                | 100%-25% LOAD |                   |                        | lbs.      | kg.  |
| PRR 12-77M    | 12         | 0-77 | 0.75                         | 1.5           | 1                 | 50mV                   | 63        | 28.6 |
| PRR 12-77M-50 | 12         | 0-62 | 0.75                         | 1.5           | 1                 | 50mV                   | 63        | 28.6 |
| PRR 24-42M    | 24         | 0-42 | 1.0                          | 2.0           | 2                 | 30mV                   | 63        | 28.6 |
| PRR 24-42M-50 | 24         | 0-34 | 1.0                          | 2.0           | 2                 | 30mV                   | 63        | 28.6 |
| PRR 28-36M    | 28         | 0-36 | 1.0                          | 2.0           | 2                 | 25mV                   | 63        | 28.6 |
| PRR 28-36M-50 | 28         | 0-29 | 1.0                          | 2.0           | 2                 | 25mV                   | 63        | 28.6 |
| PRR 48-22M    | 48         | 0-22 | 1.5                          | 2.5           | 3                 | 10mV                   | 63        | 28.6 |
| PRR 48-22M-50 | 48         | 0-18 | 1.5                          | 2.5           | 3                 | 10mV                   | 63        | 28.6 |

Models with suffix "-50" operate from 50 Hz input sources  
Models without this suffix operate from 60 Hz input sources.

TABLE 1 SPECIFICATIONS, PRR GROUP

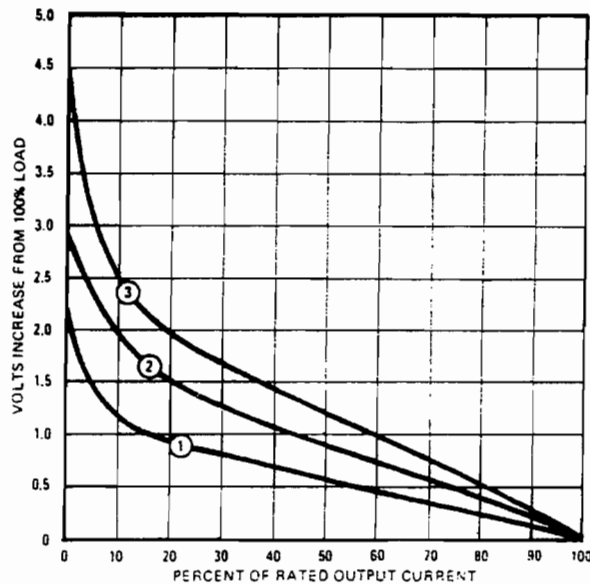

FIG. 2 TYPICAL LOAD EFFECT CURVES FOR PRR MODELS

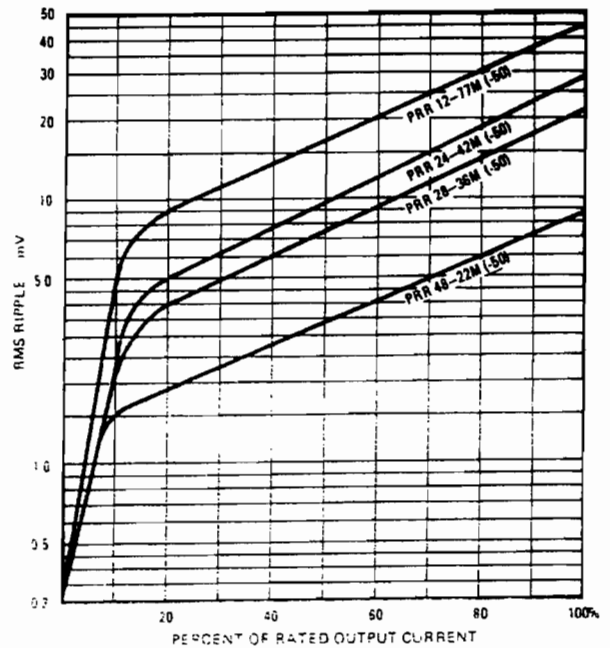

FIG. 3 TYPICAL OUTPUT RIPPLE CURVES FOR PRR MODELS

## SPECIFICATIONS, ELECTRICAL (cont'd.)

### DYNAMICS

- A) **VOLTAGE RECOVERY TIME:** The time required for the stabilized voltage to recover from a 50% step in load current to within the specified load effect band is less than 200 milliseconds.
- B) **OUTPUT IMPEDANCE:** The impedance at d-c and at frequencies below 10 KHz is a function of the load effect curves shown in FIG. 2. It may be determined from the slope of the plotted curves ( $Z_o = \Delta E_o / \Delta I_o$ ). The output impedance at frequencies above 10 KHz can be computed by adding the effect of a 2  $\mu$ H series inductance to the low frequency value found in FIG. 2.

**COOLING:** Built-in forced air (fan) keeps the components in the PRR at safe operating temperatures. Full output power is delivered at 55°C. **NOTE:** CABINET OPENINGS ON THE PRR MUST BE KEPT CLEAR OF OBSTRUCTIONS.

**ISOLATION:** The output of the PRR is isolated from the chassis and ground. It can be floated to a maximum of 600V (d-c or peak) off ground. The common mode current between either output and ground is less than 50 $\mu$ A rms (500 $\mu$ A peak to peak) at 60 Hertz.

**CURRENT LIMITING:** The Kepco FLUX-O-TRAN<sup>1</sup> power transformer provides automatic current limiting at 125 to 150% of the rated load current, depending on the source voltage level.

**BROWN-OUT PROTECTION:** The PRR power supply functions (with reduced loading capacity) with reduced a-c input source levels to 75% of nominal.

**SERIES/PARALLEL CONNECTION OF PRR SUPPLIES:** For increased output voltage, PRR power supplies can be connected in series up to their isolation specification (600V max.). **Identical** PRR supplies may be paralleled for increased output current. To allow for imbalance, the total current must be derated by 10%, when connected in parallel.

**STANDARDS:** PRR power supplies are designed and tested in accord with the NEMA Standard for stabilized power supplies, d-c output, Publication No. PY-1-1972.

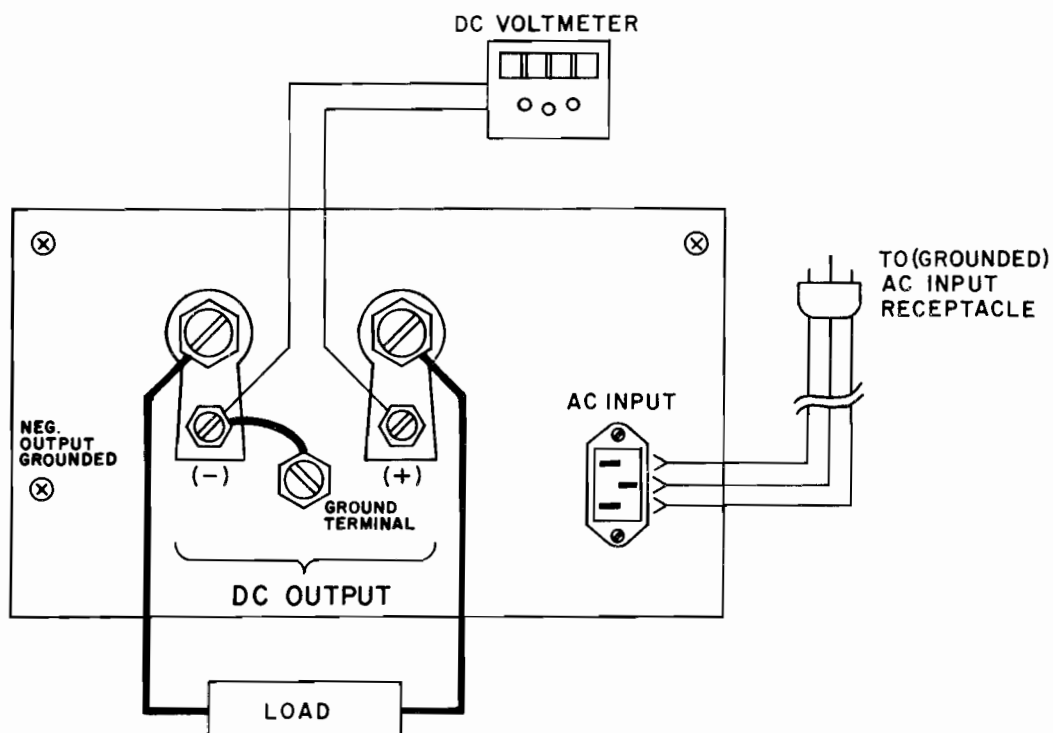

FIG 4 REAR TERMINATIONS, LOAD CONNECTIONS AND TECHNIQUE FOR MEASURING OUTPUT EFFECTS, PRR GROUP.

**REAR TERMINATIONS AND LOAD CONNECTIONS:** Figure 4 shows the rear terminations, the load connections and the techniques for measuring output effects. The load wires should be short, and as heavy as practicable.

**GROUNDING (Safety):**

**WARNING**

**FOR SAFETY REASONS, THE CASE OF THIS POWER SUPPLY MUST BE GROUNDED AT ALL TIMES. AUTOMATIC SAFETY GROUNDING IS ACHIEVED BY USE OF THE PROVIDED 3-WIRE LINE CORD AND A SECURELY GROUNDED A-C OUTLET. IF A GROUNDED A-C OUTLET IS NOT AVAILABLE, THE CASE OF THE PRR MUST BE GROUNDED WITH A SEPARATE WIRE FROM THE PROVIDED GROUND TERMINAL ON THE PRR (SEE FIG. 4) TO A RELIABLE GROUND.**

**GROUNDING (Signal):** For minimum ripple and noise, the PRR output/load circuit should be signal grounded as shown in FIG. 4. **Either** side of the output may be grounded, directly at the output terminals of the PRR as shown in FIG. 4, or at the load. If the PRR output must be operated without a ground (floating), capacitive grounding may be employed if necessary.

**OUTPUT EFFECT MEASUREMENTS:** The output specifications of the PRR may be verified by connecting a suitable voltmeter to the output terminals in FIG. 4, and varying the a-c power line (Source Effect measurement) and the load (Load Effect measurement) over the specified ranges. The meter connection shown in FIG. 4 minimizes voltage drops due to current flow and thus provides correct test results. Ripple specifications may be verified by connecting a suitable rms reading voltmeter in place of the d-c voltmeter.

# SPECIFICATIONS, MECHANICAL

**DIMENSIONS:** See Mechanical Outline Drawing, FIG. 5.

**MATERIAL:** CHASSIS: 14 Ga. CRS, FRONT PANEL: 1/8" thick aluminum, COVER: 16 Ga. CRS.

**FINISH:** CHASSIS: Cadmium plated, Chromate wash; FRONT PANEL: Light gray Fed. Std. 595, Color No. 26440; COVER: Charcoal gray, vinyl texture.

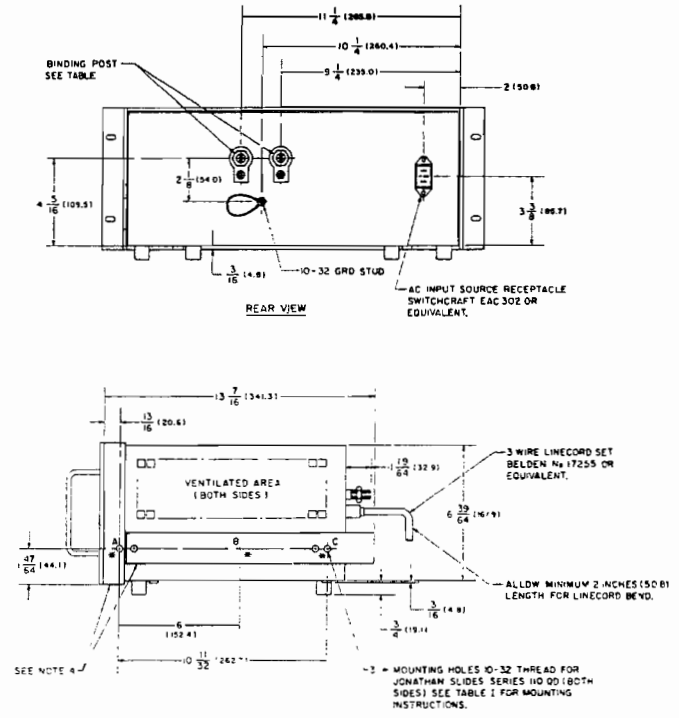
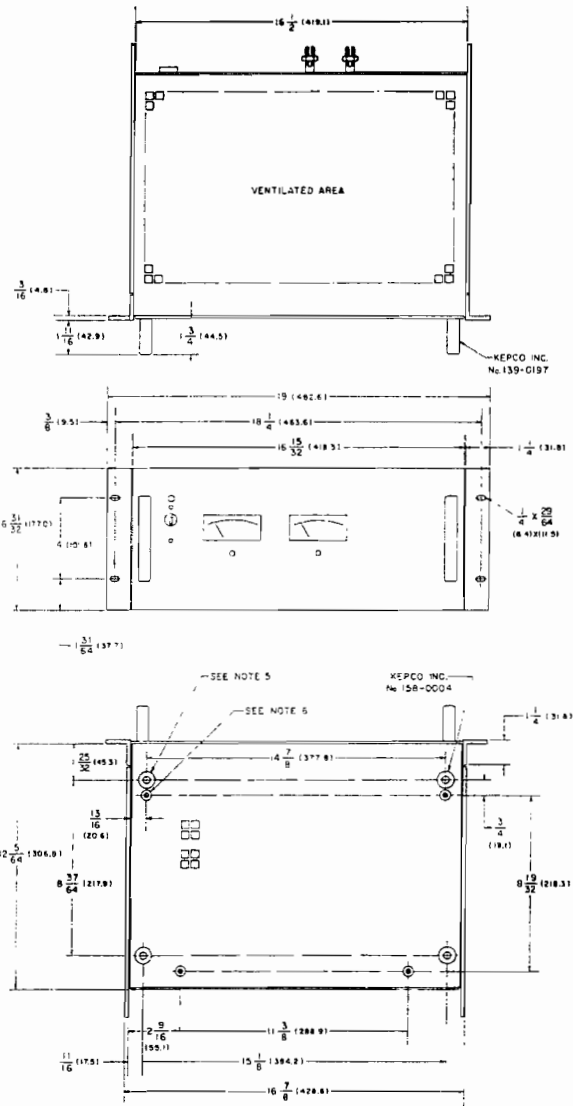

- NOTES:**
- 1 - THIS DRAWING IS USED FOR MODELS: PRR12-77M, PRR24-42M, PRR28-36M, PRR48-22M, PRR12-77M-50, PRR24-42M-50, PRR28-36M-50, PRR48-22M-50.
  - 2 - MATERIAL: A - CHASSIS: #14 GA. C.R.S. B - FRONT PANEL: 1/8 THK. ALUMINUM. C - COVER: #16 GA. C.R.S.
  - 3 - FINISH: A - CHASSIS: CADMIUM PLATE WITH CHROMATE WASH. B - FRONT PANEL: LIGHT GRAY PER FEDERAL STD. 595, COLOR No. 26440. C - COVER: CHARCOAL GRAY VINYL TEXTURE.
  - 4 - FIXED ANGLE BRACKETS AND CHASSIS SLIDE SUPPORT BARS (BOTH SIDES) USED FOR RACK OR CABINET INSTALLATION CAN BE REMOVED FOR BENCH OPERATION.
  - 5 - RACK OR CABINET MOUNTING: REMOVE (4) METAL FEET.
  - 6 - (4) PLASTIC INSERTS FOR #4-20 THREAD CUTTING SCREWS, 3/8 LONG [ WITH 1/8 THICK MOUNTING PLATE ].
  - 7 - IF INSTALLATION WITHOUT SLIDES IS DESIRED, THE UNIT MUST BE SUPPORTED BY A RIGID PLATFORM OR BY FIXED BRACKET MOUNTED ON THE RACK. SLIDES AND RIGID PLATFORM NOT SUPPLIED.
  - 8 - DIMENSIONS IN PARENTHESES ARE IN MILLIMETERS.
  - 9 - TOLERANCES: A - BETWEEN MOUNTING HOLES ± 1/64 ( ± 0.4 ) B - ALL FRONT PANEL DIMENSIONS TO MIL STD 189 C - ALL OTHER DIMENSIONS ± 1/32 ( ± 0.8 ) EXCEPT AS NOTED.

| CONDUCTORS |       | BINDING POST-BRUNDY NO. | MODEL NO. |         |   |
|------------|-------|-------------------------|-----------|---------|---|
| STRANDED   | SOLID |                         |           |         |   |
| 8 GA.      | 2 GA. | 10 GA.                  | 1 GA.     | K2C23BI | PRR 12-77M(-50)                                   |
| 10 GA.     | 7 GA. | 10 GA.                  | 6 GA.     | K2C17   | PRR 28-36M(-50), PRR 48-22M(-50), PRR 24-42M(-50) |

| SLIDE TYPE  | USED MOUNTING HOLE |   |   |
|-------------|--------------------|---|---|
|             | A                  | B | C |
| 110 QD-20-2 | ✗                  | ✗ | ● |
| 110 QD-22-2 | ✗                  | ✗ | ● |
| 110 QD-24-2 | ✗                  | ✗ | ● |

● "C" HOLE (0.199 DIA.) HAS TO BE ADDED TO SLIDES 110 QD-20-2, 110 QD-22-2 AND 110 QD-24-2.

FIG. 5 MECHANICAL OUTLINE, PRR GROUP.

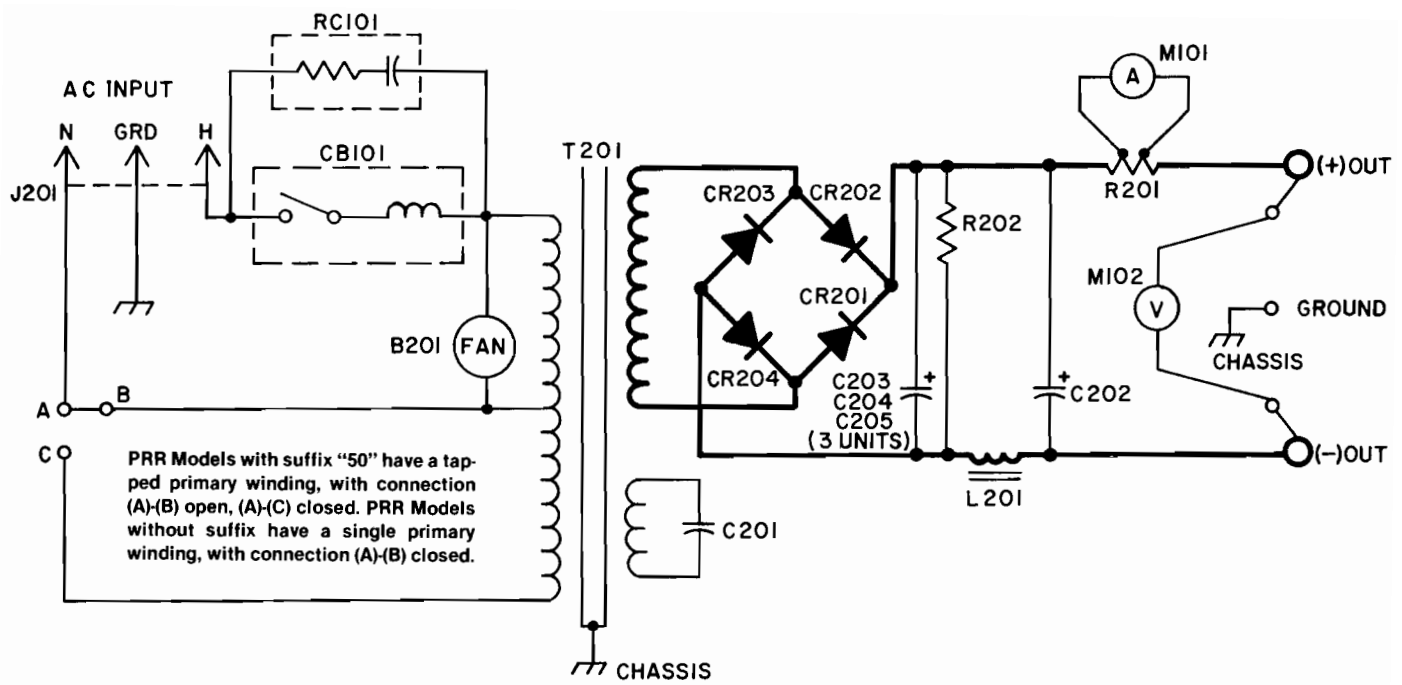

FIG. 6 SCHEMATIC DIAGRAM, PRR GROUP

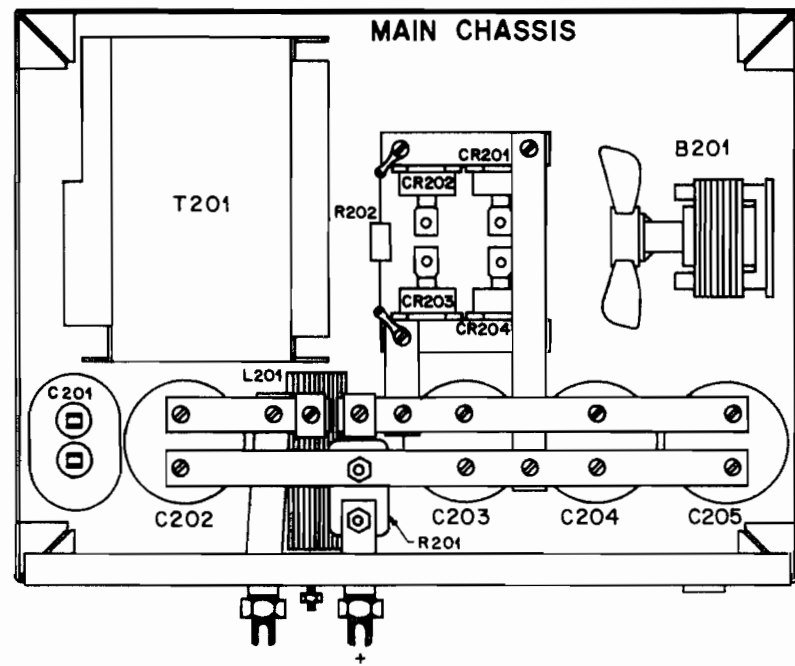
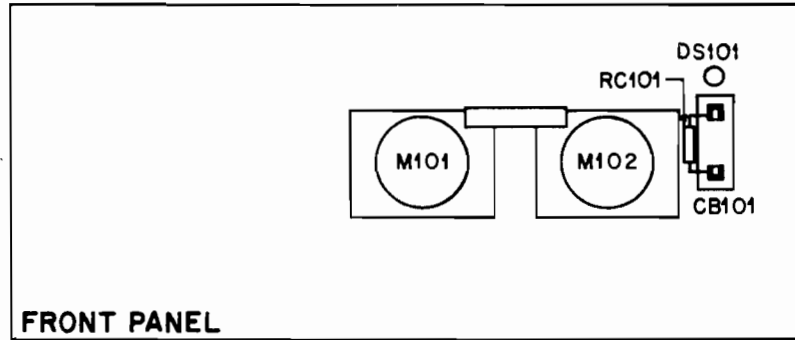

FIG. 7 COMPONENT LOCATION, PRR GROUP.





# KEPCO® REPLACEMENT PARTS LIST

PRR 28-36M (-50)

CHASSIS ASSEMBLY (A2) WITH FRONT PANEL

Code 06-1680

| REFERENCE DESIGNATION | QTY. | DESCRIPTION | MFRS. NAME & PART NO.<br>SEE BOTTOM NOTE | KEPCO PART NO. | REC. SPARE PART QTY. |
|-----------------------|------|-------------|--|----------------|----------------------|
|-----------------------|------|-------------|--|----------------|----------------------|

### FRONT PANEL ASS'Y ( PART OF A2 ) CONTAINS:

|                      |   |   |                                     |          |   |
|----------------------|---|---|-------------------------------------|----------|---|
| CB101 <sup>(1)</sup> | 1 | Circuit Breaker/Switch<br>Series Trip, 15A, 240V  | Heinemann<br>JA1-A8-A-15-10         | 127-0330 | 1 |
| CB101 <sup>(2)</sup> | 1 | Circuit Breaker/Switch<br>Series Trip, 7.5A, 240V | Heinemann<br>JA1-A8-A-7.5-10        | 127-0360 | 1 |
| DS101                | 1 | Front Panel Pilot Light<br>115V AC, Red           | Industrial Devices<br>2100-GF-I-187 | 152-0087 | 1 |
| M101                 | 1 | Meter, Ampere (Ext. Shunt)<br>0 to 50A, (50mV)    | Beede Electronics<br>Type QAW-25    | 135-0510 | 1 |
| M102                 | 1 | Meter Volt (0-40V)<br>1K ohm/V                    | Beede Electronics<br>Type QAW-25    | 135-0513 | 1 |
| RC101                | 1 | R-C Network                                       | Sprague<br>Type 288P                | 245-0003 | 1 |

### CHASSIS ASS'Y (A2) CONTAINS:

|                     |   |   |                                    |          |   |
|---------------------|---|---|------------------------------------|----------|---|
| B201                | 1 | Fan, Motor                                      | Howard Industries<br>23112         | 148-0027 | 1 |
| N.A.                | 1 | Fan, Blade<br>4 1/4", Nylon                     | Howard Industries<br>149-0023      | 149-0023 | 1 |
| C201 <sup>(1)</sup> | 1 | Cap., Paper/Oil, Can, Oval<br>10uF, 6%, 660V AC | General Electric<br>Type 26F       | 117-0931 | 1 |
| C201 <sup>(2)</sup> | 1 | Cap., Paper, Can, Oval<br>8uF, ±6%, 660V AC     | General Electric<br>Type 26F       | 117-0873 | 1 |
| C202,203<br>204,205 | 4 | Cap., Elect., Can<br>66KuF, +75, -10%, 50V      | Sprague<br>Type 36DX               | 117-0886 | 1 |
| CR201,202           | 2 | Diode, Rect., Stud-Mtg.<br>100V, 70A            | International Rectifier<br>70H10A  | 124-0379 | 1 |
| CR203,204           | 2 | Diode, Rect., Stud-Mtg.<br>100V, 70A            | International Rectifier<br>70HR10A | 124-0494 | 1 |
| J201                | 1 | AC Input Jack<br>3 Term.                        | Switchcraft<br>EAC-302             | 143-0290 | 1 |
| L201                | 1 | Filter Choke                                    | Kepeco Inc.<br>100-2090            | 100-2090 | 1 |
| R201                | 1 | RES., 4 Term. Type<br>50mV at 50A               | Empco Mfr. Corp.<br>MSA300         | 115-2637 | 1 |
| R202                | 1 | RES., FXD, Power, W.W.<br>150 ohm, 20W          | Memco<br>Type FRL-20               | 115-2371 | 1 |
| T201 <sup>(1)</sup> | 1 | Transformer, Power                              | Kepeco Inc.<br>100-2088            | 100-2088 | 1 |
| T201 <sup>(2)</sup> | 1 | Transformer, Power                              | Kepeco Inc.<br>100-2102            | 100-2102 | 1 |

(1) Used in Model PRR28-36M only.

(2) Used in Model PRR-28-36M-50 only.

NOTE: REPLACEMENT PARTS MAY BE ORDERED FROM KEPCO, INC. ORDERS SHOULD INCLUDE KEPCO PART NUMBER AND DESCRIPTION.

PLEASE NOTE: THE MANUFACTURER'S NAME AND PART NUMBER LISTED FOR EACH ITEM ON REPLACEMENT PARTS LISTS REPRESENTS AT LEAST ONE SOURCE FOR THAT ITEM AND IS LISTED SOLELY FOR THE CONVENIENCE OF KEPCO EQUIPMENT OWNERS IN OBTAINING REPLACEMENT PARTS LOCALLY. WE RESERVE THE RIGHT TO USE EQUIVALENT ITEMS FROM ALTERNATE SOURCES. KEPCO, INC.



## INSTRUCTION MANUAL CORRECTION

Please note the following corrections to the Manual material as indicated:

### Parts List and Schematic Diagram

- |    |                   |   |                            |                   |
|----|-------------------|---|----------------------------|-------------------|
| 1. | CHANGE: B201      | Motor,Fan   | 115Vac,50/60Hz             | Kepeco #148-0027  |
|    | To: B201          | Motor,Fan   | 115Vac,50/60Hz             | Kepeco #148-0049  |
| 2. | CHANGE:           | Blade,Fan,CW Rotation   | 4.25" Dia.,5 Blade,Nylon   | Kepeco #149-0023  |
|    | To:               | Blade,Fan,CW Rotation   | 4.25" Dia.,5 Blade,7/32HUB | Kepeco #149-0031  |
| 3. | CHANGE: C202-C205 | Capacitor   | 66,000uF, 30V, +75, -10%   | Kepeco #117-0886  |
|    | To: C202-C205     | Capacitor   | 78,300uF min., 50V         | Kepeco #117-1297  |
| 4. | CHANGE:           | Grommet, (qty 4)  |                            | Kepeco # 105-0031 |
|    | To:               | Grommet, Closed (qty4)  |                            | Kepeco # 105-0046 |
| 5. | SCREW:            | Screw, (qty 4)  | HXSW, 8-18x0.6255 ST       | Kepeco # 101-0327 |
|    | To:               | Screw (qty4)  | THPH, 8-18x0.6255 ST       | Kepeco # 101-0328 |
| 6. | NOTE:             | Changes 4 and 5 above changes dielectric strength as follows: |                            |                   |
|    |                   | a. From source power input or output terminals to chassis, or |                            |                   |
|    |                   | b. From source power input to output terminals:               |                            |                   |
|    | CHANGE:           | 600Vrms   |                            |                   |
|    | To:               | 2000Vrms for 60 Seconds, leakage current less than 1.5mA.     |                            |                   |
| 7. | CHANGE: DS101     | Pilot Light   | 115V a-c, Red              | Kepeco # 152-0087 |
|    | To: DS101         | LED Indicator   | 115V a-c, Red              | Kepeco # 152-0115 |

|                       |        |
|-----------------------|--------|
| PRR 28-36M/06-1295/r5 | C7318  |
| PRR 28-36M/06-1295/r6 | C12906 |
| PRR 28-36M/06-1295/r7 | C13429 |
| PRR 28-36M/06-1295/r8 | C14124 |